

冷压针
Crimp contacts



H-B

冷压针

Crimp contacts

5A 冷压接插针-标准型, 适用于HM、EMC-008、D-SUB、HR23插芯
Crimp contacts 5A-Standard for HM、EMC-008、D-SUB、HR23 inserts

接触电阻 $\leq 3m\Omega$
Contact resistance $\leq 3m\Omega$

镀银/Silver plated



镀金/Gold plated



公/Male		母/Female	
CSSM-0.25		CSSF-0.25	
CSSM-0.33		CSSF-0.33	
CSSM-0.52		CSSF-0.52	
CSSM-0.82		CSSF-0.82	
CSGM-0.25		CSGF-0.25	
CSGM-0.33		CSGF-0.33	
CSGM-0.52		CSGF-0.52	
CSGM-0.82		CSGF-0.82	

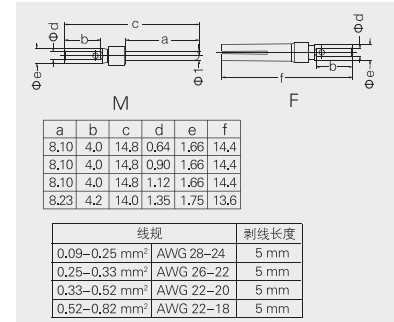

10A 冷压接插针-标准型, 适用于HD、HDD、HM、HK、HQ插芯
Crimp contacts 10A-Standard for HD、HDD、HM、HK、HQ inserts

接触电阻 $\leq 3m\Omega$
Contact resistance $\leq 3m\Omega$

镀银/Silver plated



镀金/Gold plated



公/Male		母/Female	
CDSM-0.37		CDSF-0.37	
CDSM-0.50		CDSF-0.50	
CDSM-0.75		CDSF-0.75	
CDSM-1.0		CDSF-1.0	
CDSM-1.5		CDSF-1.5	
CDSM-2.5		CDSF-2.5	
CDGM-0.37		CDGF-0.37	
CDGM-0.50		CDGF-0.50	
CDGM-0.75		CDGF-0.75	
CDGM-1.0		CDGF-1.0	
CDGM-1.5		CDGF-1.5	
CDGM-2.5		CDGF-2.5	

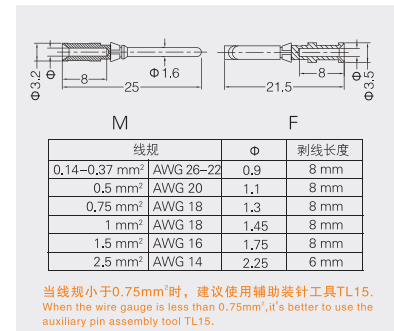

10A 冷压接插针-加强型 I (防偏向对插), 适用于HD、HDD、HM、HK、HQ插芯
Crimp contacts 10A-Enhanced I (prevent deflected insertion) for HD、HDD、HM、HK、HQ inserts

接触电阻 $\leq 3m\Omega$
Contact resistance $\leq 3m\Omega$

镀银/Silver plated



镀金/Gold plated



公/Male		母/Female	
CDSM-0.37		CDSF-0.37C	
CDSM-0.50		CDSF-0.50C	
CDSM-0.75		CDSF-0.75C	
CDSM-1.0		CDSF-1.0C	
CDSM-1.5		CDSF-1.5C	
CDSM-2.5		CDSF-2.5C	
CDGM-0.37		CDGF-0.37C	
CDGM-0.50		CDGF-0.50C	
CDGM-0.75		CDGF-0.75C	
CDGM-1.0		CDGF-1.0C	
CDGM-1.5		CDGF-1.5C	
CDGM-2.5		CDGF-2.5C	

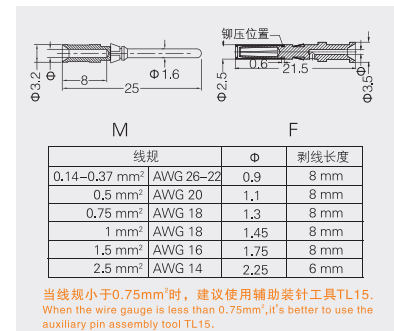

10A 冷压接插针-加强型 II (防偏向对插), 适用于HD、HDD、HM、HK、HQ插芯
Crimp contacts 10A-Enhanced II (prevent deflected insertion) for HD、HDD、HM、HK、HQ inserts

接触电阻 $\leq 3m\Omega$
Contact resistance $\leq 3m\Omega$

镀银/Silver plated



镀金/Gold plated



公/Male		母/Female	
CDSM-0.37B		CDSF-0.37B	
CDSM-0.50B		CDSF-0.50B	
CDSM-0.75B		CDSF-0.75B	
CDSM-1.0B		CDSF-1.0B	
CDSM-1.5B		CDSF-1.5B	
CDSM-2.5B		CDSF-2.5B	
CDGM-0.37B		CDGF-0.37B	
CDGM-0.50B		CDGF-0.50B	
CDGM-0.75B		CDGF-0.75B	
CDGM-1.0B		CDGF-1.0B	
CDGM-1.5B		CDGF-1.5B	
CDGM-2.5B		CDGF-2.5B	

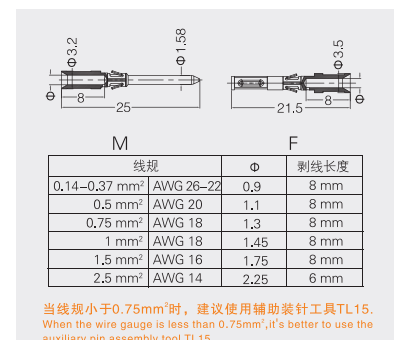

冷压针 Crimp contacts

16A 冷压接插针-标准型, 适用于HAC、HEC、D-SUB、HR23插芯
Crimp contacts 16A-Standard for HAC、HEC、D-SUB、HR23 inserts

接触电阻 ≤ 1mΩ
Contact resistance ≤ 1mΩ

镀银/Silver plated



镀金/Gold plated



公/Male	母/Female
CESM-0.37	CESF-0.37
CESM-0.50	CESF-0.50
CESM-0.75	CESF-0.75
CESM-1.0	CESF-1.0
CESM-1.5	CESF-1.5
CESM-2.5	CESF-2.5
CESM-3.0	CESF-3.0
CESM-4.0	CESF-4.0
CEGM-0.37	CEGF-0.37
CEGM-0.50	CEGF-0.50
CEGM-0.75	CEGF-0.75
CEGM-1.0	CEGF-1.0
CEGM-1.5	CEGF-1.5
CEGM-2.5	CEGF-2.5
CEGM-3.0	CEGF-3.0
CEGM-4.0	CEGF-4.0

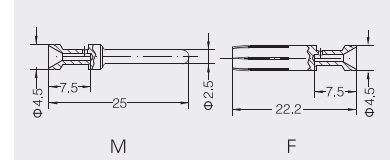

标示	线规	剥线长度
no groove	0.14-0.37 mm ²	AWG 26-22 7.5mm
no groove	0.5 mm ²	AWG 20 7.5mm
1 groove	0.75 mm ²	AWG 18 7.5mm
1 groove	1 mm ²	AWG 18 7.5mm
2 groove	1.5 mm ²	AWG 16 7.5mm
3 groove	2.5 mm ²	AWG 14 7.5mm
wide groove	3 mm ²	AWG 12 7.5mm
no groove	4 mm ²	AWG 12 7.5mm

当线规小于0.75mm²时, 建议使用辅助装针工具TL15.
When the wire gauge is less than 0.75mm², it's better to use the auxiliary pin assembly tool TL15.

16A 冷压接插针-加强(防偏向对插, 采用冠簧接触), 适用于HAC、HEC、HEE、HM、HK插芯
Crimp contacts 16A-Enhanced (prevent deflected insertion, with crown spring) for HAC、HEC、HEE、HM、HK inserts

接触电阻 ≤ 1mΩ
Contact resistance ≤ 1mΩ

镀银/Silver plated



镀金/Gold plated



公/Male	母/Female
CESM-0.37	ZCESF-0.37G
CESM-0.50	ZCESF-0.50G
CESM-0.75	ZCESF-0.75G
CESM-1.0	ZCESF-1.0G
CESM-1.5	ZCESF-1.5G
CESM-2.5	ZCESF-2.5G
CESM-3.0	ZCESF-3.0G
CESM-4.0	ZCESF-4.0G
CEGM-0.37	ZCEGF-0.37G
CEGM-0.50	ZCEGF-0.50G
CEGM-0.75	ZCEGF-0.75G
CEGM-1.0	ZCEGF-1.0G
CEGM-1.5	ZCEGF-1.5G
CEGM-2.5	ZCEGF-2.5G
CEGM-3.0	ZCEGF-3.0G
CEGM-4.0	ZCEGF-4.0G

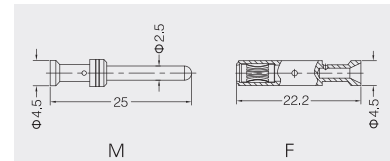

标示	线规	剥线长度
no groove	0.14-0.37 mm ²	AWG 26-22 7.5mm
no groove	0.5 mm ²	AWG 20 7.5mm
1 groove	0.75 mm ²	AWG 18 7.5mm
1 groove	1 mm ²	AWG 18 7.5mm
2 groove	1.5 mm ²	AWG 16 7.5mm
3 groove	2.5 mm ²	AWG 14 7.5mm
wide groove	3 mm ²	AWG 12 7.5mm
no groove	4 mm ²	AWG 12 7.5mm

当线规小于0.75mm²时, 建议使用辅助装针工具TL15.
When the wire gauge is less than 0.75mm², it's better to use the auxiliary pin assembly tool TL15.

16A 冷压接插针-加强 III(防偏向对插, 采用冠簧接触, 轨道交通推荐), 适用于HE-006-MC/N/FC/N、HEE-046-MC/N/FC/N插芯
Crimp contacts 16A-Enhanced III (prevent deflected insertion, with crown spring, recommended use in rail transport industry, vibration resistance) for HE-006-MC/N/FC/N、HEE-046-MC/N/FC/N inserts

接触电阻 ≤ 1mΩ
Contact resistance ≤ 1mΩ

镀银/Silver plated



镀金/Gold plated



公/Male	母/Female
CESM-0.37/N	CESF-0.37G/N
CESM-0.50/N	CESF-0.50G/N
CESM-0.75/N	CESF-0.75G/N
CESM-1.0/N	CESF-1.0G/N
CESM-1.5/N	CESF-1.5G/N
CESM-2.5/N	CESF-2.5G/N
CESM-3.0/N	CESF-3.0G/N
CESM-4.0/N	CESF-4.0G/N
CEGM-0.37/N	CEGF-0.37G/N
CEGM-0.50/N	CEGF-0.50G/N
CEGM-0.75/N	CEGF-0.75G/N
CEGM-1.0/N	CEGF-1.0G/N
CEGM-1.5/N	CEGF-1.5G/N
CEGM-2.5/N	CEGF-2.5G/N
CEGM-3.0/N	CEGF-3.0G/N
CEGM-4.0/N	CEGF-4.0G/N

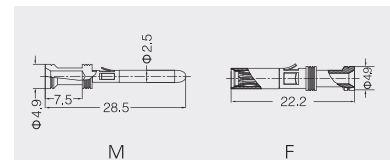

标示	线规	剥线长度
no groove	0.14-0.37 mm ²	AWG 26-22 7.5mm
no groove	0.5 mm ²	AWG 20 7.5mm
1 groove	0.75 mm ²	AWG 18 7.5mm
1 groove	1 mm ²	AWG 18 7.5mm
2 groove	1.5 mm ²	AWG 16 7.5mm
3 groove	2.5 mm ²	AWG 14 7.5mm
wide groove	3 mm ²	AWG 12 7.5mm
no groove	4 mm ²	AWG 12 7.5mm

当线规小于0.75mm²时, 建议使用辅助装针工具TL15.
When the wire gauge is less than 0.75mm², it's better to use the auxiliary pin assembly tool TL15.

不能与上面两款16A针搭配使用
公针退针器: TL00
母针退针器: TL09
Can not be compatible use with above two 16A Crimp contacts.
Male contact removal tool: TL00
Female contact removal tool: TL09

40A 冷压接插针-标准型, 适用于HM、HK插芯
Crimp contacts 40A-Standard for HM、HK inserts

接触电阻 $\leq 1\text{m}\Omega$
Contact resistance $\leq 1\text{m}\Omega$

镀银/Silver plated



镀金/Gold plated



公/Male	母/Female
CCSM-1.5	CCSF-1.5
CCSM-2.5	CCSF-2.5
CCSM-4.0	CCSF-4.0
CCSM-6.0	CCSF-6.0
CCSM-10.0	CCSF-10.0
CCGM-1.5	CCGF-1.5
CCGM-2.5	CCGF-2.5
CCGM-4.0	CCGF-4.0
CCGM-6.0	CCGF-6.0
CCGM-10.0	CCGF-10.0

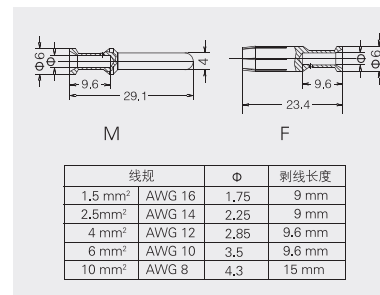

40A 冷压接插针-加强型(防偏向对插, 高拔插寿命, 采用冠簧接触), 适用于HK插芯
Crimp contacts 40A-Enhanced(prevent deflected insertion, high mating cycle, with crown spring) for HK inserts

接触电阻 $\leq 1\text{m}\Omega$
Contact resistance $\leq 1\text{m}\Omega$

镀金/Gold plated



公/Male	母/Female
CCGMH-1.5	CCGFH-1.5
CCGMH-2.5	CCGFH-2.5
CCGMH-4.0	CCGFH-4.0
CCGMH-6.0	CCGFH-6.0
CCGMH-10.0	CCGFH-10.0

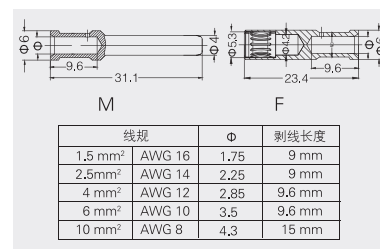

70A 冷压接插针, 适用于HM插芯
Crimp contacts 70A for HM inserts

接触电阻 $\leq 0.5\text{m}\Omega$
Contact resistance $\leq 0.5\text{m}\Omega$

镀银/Silver plated



公/Male	母/Female
CKSM70-6	CKSF70-6
CKSM70-10	CKSF70-10
CKSM70-16	CKSF70-16
CKSM70-25	CKSF70-25

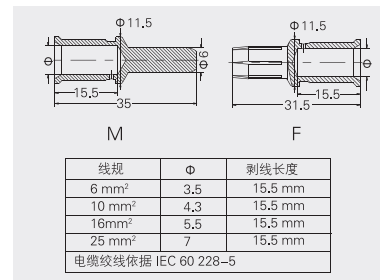

100A 冷压接插针(采用冠簧接触), 适用于HK插芯
Crimp contacts 100A(with crown spring) for HK inserts

接触电阻 $\leq 0.3\text{m}\Omega$
Contact resistance $\leq 0.3\text{m}\Omega$

镀银/Silver plated



公/Male	母/Female
CKSM-10	CKSF-10G
CKSM-16	CKSF-16G
CKSM-25	CKSF-25G
CKSM-35	CKSF-35G
开槽结构/Slotted construction	
	CKSF-10
	CKSF-16
	CKSF-25
	CKSF-35

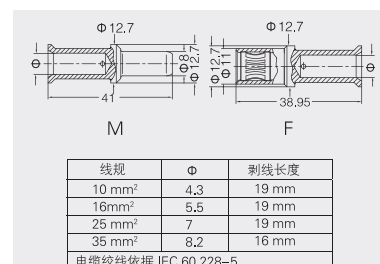

200A 冷压接插针, 适用于HM插芯
Crimp contacts 200A for HM inserts

接触电阻 $\leq 0.3\text{m}\Omega$
Contact resistance $\leq 0.3\text{m}\Omega$

镀银/Silver plated



公/Male	母/Female
CHSM200-25	CHSF200-25
CHSM200-35	CHSF200-35
CHSM200-50	CHSF200-50
CHSM200-70	CHSF200-70

