

01



TWIST DRILLS

Overview of symbols	14 – 15
Type and applications overview	18 – 21
ULTIMATECUT DIN 338 type FLOWSTEP®, HSSE-Co 5	22
ULTIMATECUT DIN 338 type FLOWSTEP®, HSS	23
ULTIMATECUT DIN 338 type FLOWSTEP® + machine tap M DIN 371 / 376 form B	24
ULTIMATECUT DIN 338 type FLOWSTEP® + single-cut tap M ≈ DIN 352 HSS	24
DIN 338 type VA, HSSE-Co 8 + TiAlN	26 – 28
DIN 338 type VA, HSSE-Co 5	30 – 32
DIN 338 type VA, HSSE-Co 5 – <i>inch dimensions</i>	33
DIN 338 type UNI, HSSE-Co 5	34
DIN 338 TL 3000, HSS + TiAlN	36 – 37
DIN 338 type N, HSS + TiN	38 – 41
DIN 338 type N, HSS – <i>inch dimensions</i>	42
DIN 338 type N, HSS TiN – <i>inch dimensions</i>	43
DIN 338 type N, HSS-G with TiN tip coating	44
DIN 338 type N, HSS – <i>left-hand cutting</i>	45
DIN 338 type N, HSS-R	46 – 48
DIN 338 type N, HSS-R + HSS VAP + HSSE-Co 5 with reduced shank	49
DIN 340 type N, HSS-G	50
DIN 1869 TL 3000, HSS – <i>extra long</i>	51
DIN 345 type N, HSS + HSSE-Co 5	52 – 53
DIN 1897 type N, HSSE-Co 5 – <i>short</i>	54
DIN 1897 type N, HSS + TiN – <i>short</i>	55
Double end drill type KV, HSS	56
Centre drill DIN 333, HSS	56
Use of the drills and cutting conditions	57
Speed table for twist drills	58 – 59



ULTIMATECUT[®]

Twist drill with FLOWSTEP[®] tip



RUKO FLOWSTEP[®] tip

Precise centering = no slipping when positioning.
Time saving due to faster drilling = more holes drilled in the same time.
Power-saving drilling = more holes without a break.



RUKO 3-surface shaft

No slipping in the drill chuck, therefore optimum power transmission.

No more retensioning in the drill chuck, making work simple and uncomplicated.



RUKO black bevel

The black bevel increases wear resistance and at the same time reduces cold welding at the groove edges.

Overview of symbols

Drill types

N	Type N Helix angle: 20 – 30° Profile of flute: normal Core: normal Point angle: 118 – 130°
TL 3000	Type TL 3000 Helix angle: 40° Profile of flute: wide with rounded rear edges Core: thick Point angle: 130° Point cut: shape C
UTL 3000	Type UTL 3000 Helix angle: 40° Profile of flute: wide with rounded rear edges Core: very thick Point angle: 130° Point cut: shape U
UNI	Type UNI Helix angle: 40° Profile of flute: wide, for better chip removal Core: normal Centre angle: 135° Point cut: shape C
VA	Type VA Helix angle: 36° Profile of flute: normal Core: thickened Point angle: 130° Point cut: shape C
KV	Type KV Helix angle: 25 – 30° Profile of flute: normal Core: normal Point angle: 130° Point cut: Form C
FT	Type FLOWSTEP® Helix angle: 20 – 30° Profile of flute: normal Core: normal Stepped tip type FLOWSTEP® tip

DIN standards

DIN 333	Centre drills 60° shape A and R
DIN 345	Twist drills with morse taper shank
DIN 338	Short twist drills with straight shank
DIN 1869	Extra long twist drills with straight shank
DIN 340	Long twist drills with straight shank
DIN 1897	Extra short twist drills with straight shank

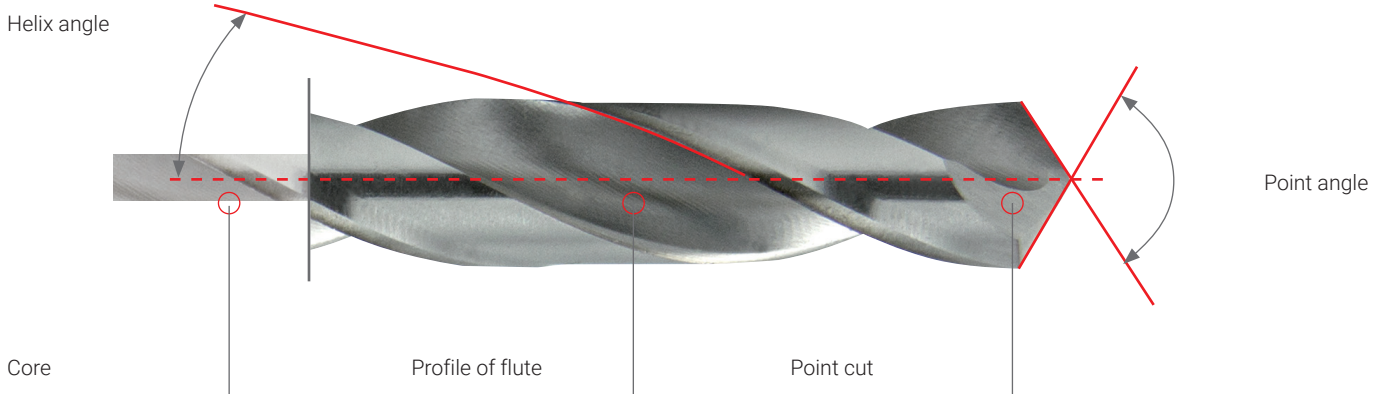

Point grinding and pointing according to DIN 1412



Shape N: Helical point normal ground

Application: For all normal drilling work in steel, non-ferrous metal and plastic. The point angles depend on the ease with which the materials can be cut.

Advantages: Powerful main cut, resistant to impact and lateral forces. Simple manual grinding possible.

Disadvantages: Broad cutting edge requires considerable pressure.



Shape A: Cut chisel edge

Application: For all normal drilling work using drills with a strong core, for drilling into solid materials with larger drill diameters.

Advantages: Good centering when starting to drill, as the length of the chisel edge is reduced to 1/10 of the drill diameter, and fewer pressure is required.

Disadvantages: Additional regrinding work.



Shape B: Cut chisel edge with corrected major cutting edge

Application: For drilling high-density steel, for manganese steel with over 10 % Mn, for hard spring steel and for drilling out.

Advantages: Resistant to impact, one-way load and lateral forces. Does not catch in thin workpieces.

Disadvantages: High pressure required, tendency to slip, extra work involved in regrinding.



Shape C: Split point

Application: For high pressure required, tendency to slip, extra work involved in regrinding.

Advantages: Good centering, little pressure required. Chip spreading improves chip removal.

Disadvantages: Perfect grinding only possible by machine.



Shape D: Ground for grey cast iron

Application: For drilling grey cast iron, malleable cast iron and forgings.

Advantages: Wear on cutting corners is reduced by extended major cutting edges, resistant to impact, good heat conductivity, all giving improved tool life.

Disadvantages: Perfect regrinding only possible by machine.



Shape E: Centre point

Application: For drilling sheet-metal and soft materials, for blind holes with flat bottoms.

Advantages: Good centering, minimal formation of burrs when through-drilling, precise drilling in thin sheets and pipes, does not catch. Available in diameters of \varnothing 2.5 mm upwards.

Disadvantages: Sensitive to impact and one-way loading. Can only be ground to perfection by machine.

Other bevelling and sharpening



Shape U: Special ground

Applications: For drills with sturdy profiles suitable for use in automated processing, with narrow grooves and strong cores.

Advantages: extremely good self-centering behaviour when maximum cutting valuminiums are employed. Concave cutting produces short metal chips.

Disadvantages: Extra work involved in regrinding.

The right answer for every job

Some say, a twist drill is a twist drill.

For us, it's the right tool for each application.

**Cutting-edge
technology**



259 xxx

Premium with industry standard



281 xxx



228 xxx

Standard for professional work



215 xxx



214 xxx



201 xxx

This starts with the point grinds and the different helix and point angles, which have a significant influence on the precise drilling behaviour. This also includes the differently designed flute profiles, which optimise chip pick-up and removal and thus prevent the drill bit from annealing or even breaking. Or the core thickness, which plays a decisive role in the stability of each twist drill.

This results in twist drills with individual class. For traditional craftsmanship, for use in industry or for tasks that require highly specialised solutions.

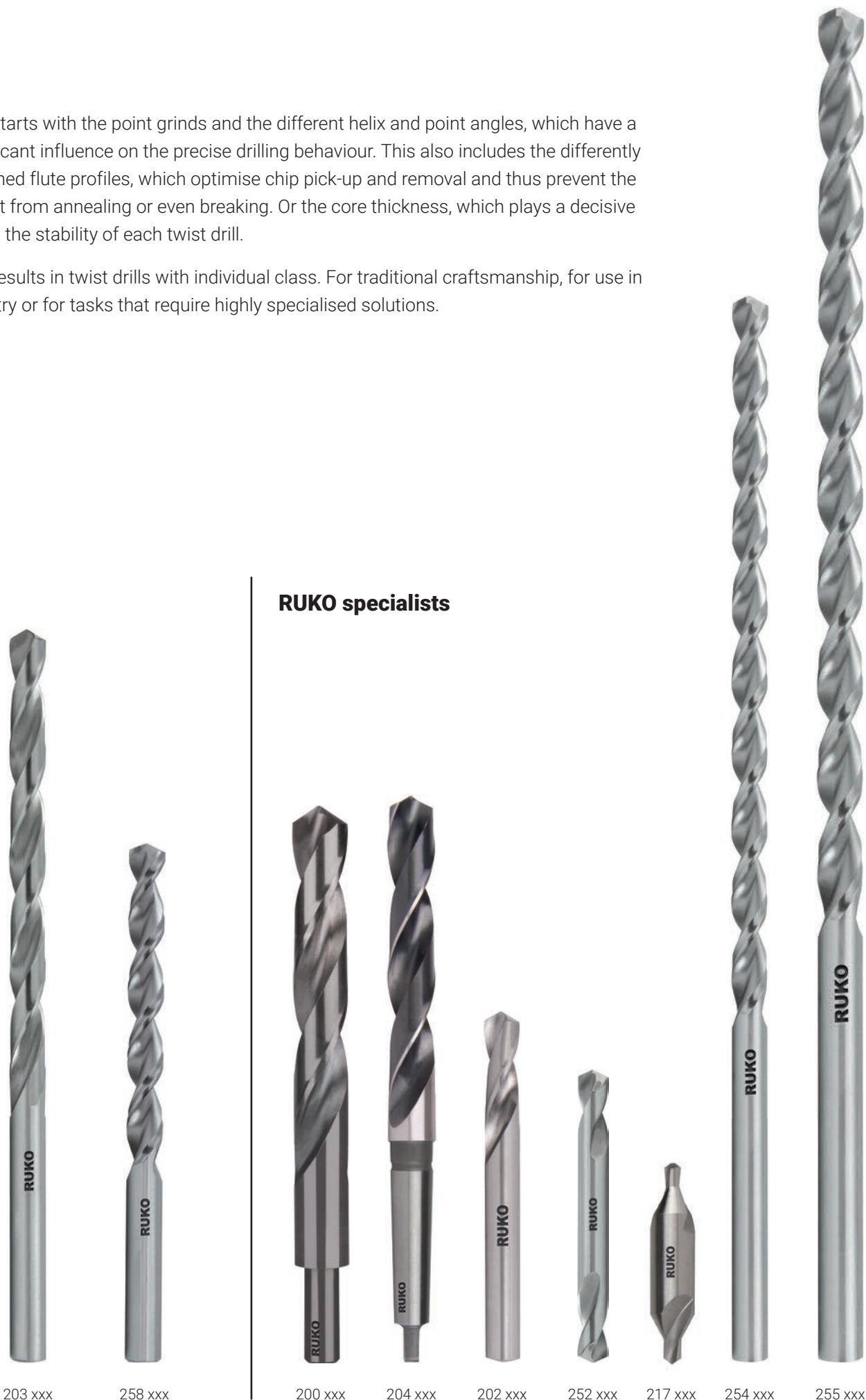

RUKO specialists

203 xxx

258 xxx

200 xxx

204 xxx

202 xxx





























































































252 xxx

217 xxx

254 xxx

255 xxx

Type and applications overview































	Material	Surface	DIN	Type	Point cut	Point angle	Spiral angle	Shank	Ø mm	Item no.	Page/s
	HSS	Blank	DIN 338	FT	 ≥ Ø 3.0 mm	 25-30°	 25-30°	 ≥ Ø 3.5 mm	1,0 – 13,0	259 xxx	23
	HSSE Co5	Bronze	DIN 338	FT	 ≥ Ø 3.0 mm	 25-30°	 25-30°	 ≥ Ø 3.5 mm		22	
	HSSE Co8	Blank	DIN 338	VA	 ≥ Ø 2.0 mm	 130°	 36°		1,0 – 16,0	281 xxx	26 – 28
	HSSE Co8	TiAlN	DIN 338	VA	 ≥ Ø 2.0 mm	 130°	 36°				
	HSSE Co5	Bronze	DIN 338	VA	 ≥ Ø 2.0 mm	 130°	 36°		1,0 – 20,0	215 xxx	30 – 32
									1/16 – 1/2 Inch	215 8xx	33
	HSSE Co5	VAP Bonze	DIN 338	UNI	 ≥ Ø 2.0 mm	 130°	 40°	 ≥ Ø 4.0 mm	1,0 – 13,0	228 xxx	34
	HSS	Blank	DIN 338	TL 3000	 ≥ Ø 2.0 mm	 130°	 40°		1,0 – 16,0	258 xxx	36 – 37
	HSS	TiAlN	DIN 338	TL 3000	 ≥ Ø 2.0 mm	 130°	 40°				
	HSS	Blank	DIN 338	N	 ≥ Ø 2.0 mm	 118°	 25-30°		0,3 – 20,0	214 xxx	38 – 41
	HSS	TiN	DIN 338	N	 ≥ Ø 2.0 mm	 118°	 25-30°		0,3 – 16,0	250 xxx T	
	HSS	Blank	DIN 338	N	 ≥ Ø 2.0 mm	 118°	 25-30°		1/16 – 1/2 Inch	214 8xx	42
	HSS	TiN	DIN 338	N	 ≥ Ø 2.0 mm	 118°	 25-30°		1/16 – 1/2 Inch	250 8xx T	43
	HSS	TiN	DIN 338	N	 ≥ Ø 2.0 mm	 118°	 25-30°		1,0 – 13,0	2501 xxx	44
	HSS	Blank	DIN 338	N	 ≥ Ø 2.0 mm	 118°	 25-30°		1,0 – 13,0	214 xxx Li	45
	HSS-R	VAP	DIN 338	N	 ≥ Ø 2.0 mm	 118°	 25-30°		0,3 – 20,0	201 xxx	46 – 48
	HSS-R	VAP	DIN 338	N	 ≥ Ø 2.0 mm	 118°	 25-30°		10,5 – 25,0	200 xxx	49
	HSS	Blank	DIN 338	N	 ≥ Ø 2.0 mm	 118°	 25-30°		10,5 – 20,0	200 4 xxx	
	HSSE Co5	Bronze	DIN 338	N	 ≥ Ø 2.0 mm	 130°	 25-30°		10,5 – 20,0	200 5 xxx	
	HSS	Blank	DIN 340	N	 ≥ Ø 2.0 mm	 118°	 25-30°		2,5 – 13,0	203 xxx	50
	HSS	Blank	DIN 1869	TL 3000	 ≥ Ø 2.0 mm	 130°	 40°		2,0 – 13,0	254 xxx	51
									3,0 – 13,0	255 xxx	

Structural steel < 900 N/mm ²	Inox <1100 N/mm ²	High strength steel <1300 N/mm ²	Brass	Bronze	Cast iron	Aluminium	Plastics
●			●	○	○	●	○
●	●		●	○	○	●	○
○	●	●	●	○	●	●	○
○	●	●	●	●	●	●	○
●	●		●	○	○		○
●	●		●	○	○		○
●			●	○	○	●	○
●	●		●	●	○	●	○
●			●	○	○	●	○
●	○		●	○	○		○
●			●	○		●	○
●	○		●	○			○
●	○		●	○	○		○
●			●	○	○	●	○
●			●	○		●	○
●			●	○	○	●	○
●	●		●	○	○	●	○
●	●	●	●	●	●	●	○
●	○		●	○			○
●	○		●	○			○

● Main application ○ Other application

Type and applications overview

01

	Material	Surface	DIN	Type	Point cut	Point angle	Spiral angle	Shank	Ø mm	Item no.	Page/s
	HSS	VAP Blank	DIN 345	N					10,0 – 60,0	204 xxx	52 – 53
	HSSE Co5	Blank	DIN 345	N					10,0 – 30,0		
	HSSE Co5	Blank	DIN 1897	N	 ≥ Ø 2,5 mm				2,0 – 13,0	202 xxx E	54
	HSS	Blank	DIN 1897	N						202 xxx	55
	HSS	TiN	DIN 1897	N						202 xxx T	
	HSS	Blank		KV	 ≥ Ø 3,0 mm				2,5 – 6,5	252 xxx	56
	HSS	Blank	DIN 333	A					0,8 – 6,3	217 xxx	56

Structural steel < 900 N/mm ²	Inox <1100 N/mm ²	High strength steel <1300 N/mm ²	Brass	Bronze	Cast iron	Aluminium	Plastics
●			●	○		●	○
●	●		●	○	○	●	○
●	●		●	○	○	●	○
●			●	○	○	●	○
●			●	○	○		○
●			●	○	○	●	○
●			●	○	○	●	○

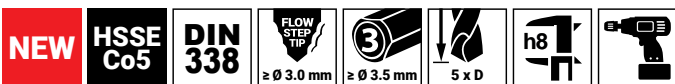
ULTIMATECUT®

ULTIMATECUT twist drill DIN 338 type FLOWSTEP®, HSSE-Co 5



FLOWSTEP® tip

- Perfect centering, avoiding slipping even on round surfaces such as pipe and tube.
- Easy and smooth drilling process, without jamming in the material.
- Extremely fast and energy-saving drilling.
- Time savings of up to 50%.
- Significantly longer tool life - up to 5x more holes possible.
- Optimal performance in hand-held (cordless) power tool drill machines.

! FLOWSTEP® tip from Ø 3.00, as from a technical application point of view there is no benefit in sizes smaller than Ø 3.00.

Packaging: plastic tube



Ø mm	L1 mm	L2 mm	HSSE-Co 5	
1.00	34.0	12.0	259 010 E	10
1.50	40.0	18.0	259 015 E	10
2.00	49.0	24.0	259 020 E	10
2.50	57.0	30.0	259 025 E	10
3.00	61.0	33.0	259 030 E	10
3.30	65.0	36.0	259 033 E	10
3.50	70.0	39.0	259 035 E	10
4.00	75.0	43.0	259 040 E	10
4.20	75.0	43.0	259 042 E	10
4.50	80.0	47.0	259 045 E	10
5.00	86.0	52.0	259 050 E	10
5.50	93.0	57.0	259 055 E	5
6.00	93.0	57.0	259 060 E	5
6.50	101.0	63.0	259 065 E	5
6.80	109.0	69.0	259 068 E	5

Ø mm	L1 mm	L2 mm	HSSE-Co 5	
7.00	109.0	69.0	259 070 E	5
7.50	109.0	69.0	259 075 E	5
8.00	117.0	75.0	259 080 E	5
8.50	117.0	75.0	259 085 E	1
9.00	125.0	81.0	259 090 E	1
9.50	125.0	81.0	259 095 E	1
10.00	133.0	87.0	259 100 E	1
10.20	133.0	87.0	259 102 E	1
10.50	133.0	87.0	259 105 E	1
11.00	142.0	94.0	259 110 E	1
11.50	142.0	94.0	259 115 E	1
12.00	151.0	101.0	259 120 E	1
12.50	151.0	101.0	259 125 E	1
13.00	151.0	101.0	259 130 E	1

		HSSE-Co 5
19 tfg./pcs.	Twist drill set DIN 338 type FLOWSTEP® Ø 1.0 mm to 10.0 mm x 0.5 mm increasing	259 214 ERO
25 tfg./pcs.	Twist drill set DIN 338 type FLOWSTEP® Ø 1.0 mm to 13.0 mm x 0.5 mm increasing	259 215 ERO



259 214 ERO

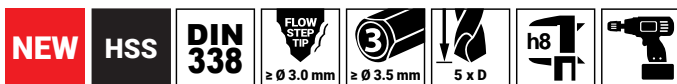

ULTIMATECUT®

01

ULTIMATECUT twist drill DIN 338 type FLOWSTEP®, HSS



FLOWSTEP® tip

- Perfect centering, avoiding slipping even on round surfaces such as pipe and tube.
- Easy and smooth drilling process, without jamming in the material.
- Extremely fast and energy-saving drilling.
- Time savings of up to 50%.
- Significantly longer tool life - up to 5x more holes possible.
- Optimal performance in hand-held (cordless) power tool drill machines.

! FLOWSTEP® tip from Ø 3.00, as from a technical application point of view there is no benefit in sizes smaller than Ø 3.00.

Packaging: plastic tube



Ø mm	L1 mm	L2 mm	HSS	
1.00	34.0	12.0	259 010	10
1.50	40.0	18.0	259 015	10
2.00	49.0	24.0	259 020	10
2.50	57.0	30.0	259 025	10
3.00	61.0	33.0	259 030	10
3.30	65.0	36.0	259 033	10
3.50	70.0	39.0	259 035	10
4.00	75.0	43.0	259 040	10
4.20	75.0	43.0	259 042	10
4.50	80.0	47.0	259 045	10
5.00	86.0	52.0	259 050	10
5.50	93.0	57.0	259 055	5
6.00	93.0	57.0	259 060	5
6.50	101.0	63.0	259 065	5
6.80	109.0	69.0	259 068	5

Ø mm	L1 mm	L2 mm	HSS	
7.00	109.0	69.0	259 070	5
7.50	109.0	69.0	259 075	5
8.00	117.0	75.0	259 080	5
8.50	117.0	75.0	259 085	1
9.00	125.0	81.0	259 090	1
9.50	125.0	81.0	259 095	1
10.00	133.0	87.0	259 100	1
10.20	133.0	87.0	259 102	1
10.50	133.0	87.0	259 105	1
11.00	142.0	94.0	259 110	1
11.50	142.0	94.0	259 115	1
12.00	151.0	101.0	259 120	1
12.50	151.0	101.0	259 125	1
13.00	151.0	101.0	259 130	1

		HSS
19 tlg./pcs.	Twist drill set DIN 338 type FLOWSTEP® Ø 1.0 mm to 10.0 mm x 0.5 mm increasing	259 214 RO
25 tlg./pcs.	Twist drill set DIN 338 type FLOWSTEP® Ø 1.0 mm to 13.0 mm x 0.5 mm increasing	259 215 RO



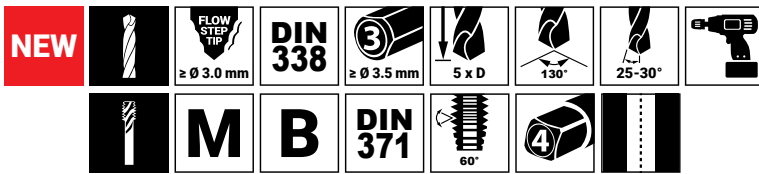

ULTIMATECUT twist drill DIN 338 type FLOWSTEP® + machine tap M DIN 371 / 376 form B



		HSS
14 fig./pcs.	Machine tap set 7 ULTIMATECUT twist drills DIN 338 type FLOWSTEP® Ø 2.5 3.3 4.2 5.0 6.8 8.5 10.2 mm + 7 Machine taps M DIN 371 / 376 Form B with peel cut M 3 M 4 M 5 M 6 M 8 M 10 M 12	259 048 RO



		HSSE-Co 5
14 fig./pcs.	Machine tap set 7 ULTIMATECUT twist drills DIN 338 type FLOWSTEP® Ø 2.5 3.3 4.2 5.0 6.8 8.5 10.2 mm + 7 Machine taps M DIN 371 / 376 Form B with peel cut M 3 M 4 M 5 M 6 M 8 M 10 M 12	259 048 ERO

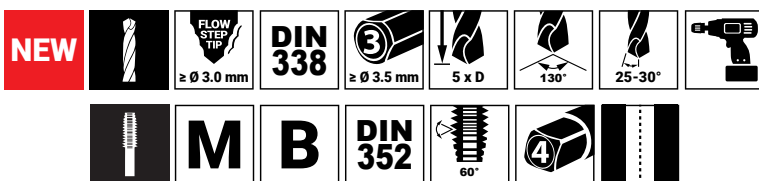

ULTIMATECUT twist drill DIN 338 type FLOWSTEP® + single-cut tap M ≈ DIN 352 HSS



		HSS
15 fig./pcs.	Single-cut tap set 7 ULTIMATECUT twist drills DIN 338 type FLOWSTEP® HSS Ø 2.5 3.3 4.2 5.0 6.8 8.5 10.2 mm + 7 single-cut taps M ≈ DIN 352 HSS, M 3 M 4 M 5 M 6 M 8 M 10 M 12	259 004 RO





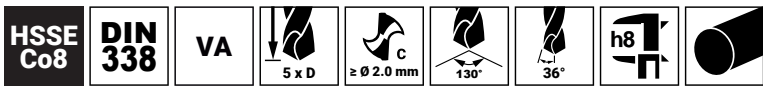

Twist drill DIN 338 type VA, HSSE-Co 8

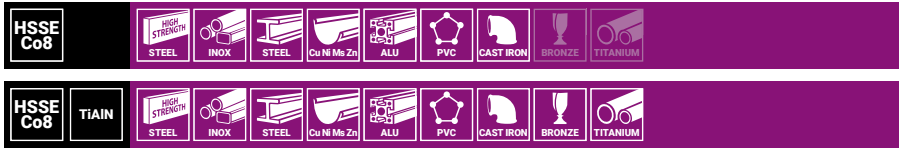



Powerful special drill that should ideally be used for titanium base alloys as well as stainless, acid-resistant and heat-resistant austenitic steels. It is also suitable for high strength steels with low ductility. Under certain conditions, these drills can be used for special alloys such as hastelloy, inconel and nimonic etc



Packaging: plastic tube

Ø mm	L1 mm	L2 mm	HSSE-Co 8		HSSE-Co 8 TiAlN	
			Part No.	Pkg	Part No.	Pkg
1.00	34.0	12.0	281 010 E	10	281 010 EF	10
1.10	36.0	14.0	281 011 E	10	281 011 EF	10
1.20	38.0	16.0	281 012 E	10	281 012 EF	10
1.30	38.0	16.0	281 013 E	10	281 013 EF	10
1.40	40.0	18.0	281 014 E	10	281 014 EF	10
1.50	40.0	18.0	281 015 E	10	281 015 EF	10
1.60	43.0	20.0	281 016 E	10	281 016 EF	10
1.70	43.0	20.0	281 017 E	10	281 017 EF	10
1.80	46.0	22.0	281 018 E	10	281 018 EF	10
1.90	46.0	22.0	281 019 E	10	281 019 EF	10
2.00	49.0	24.0	281 020 E	10	281 020 EF	10
2.10	49.0	24.0	281 021 E	10	281 021 EF	10
2.20	53.0	27.0	281 022 E	10	281 022 EF	10
2.30	53.0	27.0	281 023 E	10	281 023 EF	10
2.40	57.0	30.0	281 024 E	10	281 024 EF	10
2.50	57.0	30.0	281 025 E	10	281 025 EF	10
2.60	57.0	30.0	281 026 E	10	281 026 EF	10
2.70	61.0	33.0	281 027 E	10	281 027 EF	10
2.80	61.0	33.0	281 028 E	10	281 028 EF	10
2.90	61.0	33.0	281 029 E	10	281 029 EF	10
3.00	61.0	33.0	281 030 E	10	281 030 EF	10
3.10	65.0	36.0	281 031 E	10	281 031 EF	10
3.20	65.0	36.0	281 032 E	10	281 032 EF	10
3.30	65.0	36.0	281 033 E	10	281 033 EF	10
3.40	70.0	39.0	281 034 E	10	281 034 EF	10
3.50	70.0	39.0	281 035 E	10	281 035 EF	10
3.60	70.0	39.0	281 036 E	10	281 036 EF	10
3.70	70.0	39.0	281 037 E	10	281 037 EF	10
3.80	75.0	43.0	281 038 E	10	281 038 EF	10
3.90	75.0	43.0	281 039 E	10	281 039 EF	10
4.00	75.0	43.0	281 040 E	10	281 040 EF	10
4.10	75.0	43.0	281 041 E	10	281 041 EF	10
4.20	75.0	43.0	281 042 E	10	281 042 EF	10
4.30	80.0	47.0	281 043 E	10	281 043 EF	10
4.40	80.0	47.0	281 044 E	10	281 044 EF	10
4.50	80.0	47.0	281 045 E	10	281 045 EF	10
4.60	80.0	47.0	281 046 E	10	281 046 EF	10
4.70	80.0	47.0	281 047 E	10	281 047 EF	10
4.80	86.0	52.0	281 048 E	10	281 048 EF	10
4.90	86.0	52.0	281 049 E	10	281 049 EF	10

Ø mm	L1 mm	L2 mm	HSSE-Co 8		HSSE-Co 8 TiAlN	
						
5.00	86.0	52.0	281 050 E	10	281 050 EF	10
5.10	86.0	52.0	281 051 E	10	281 051 EF	10
5.20	86.0	52.0	281 052 E	10	281 052 EF	10
5.30	86.0	52.0	281 053 E	10	281 053 EF	10
5.40	93.0	57.0	281 054 E	10	281 054 EF	10
5.50	93.0	57.0	281 055 E	10	281 055 EF	10
5.60	93.0	57.0	281 056 E	10	281 056 EF	10
5.70	93.0	57.0	281 057 E	10	281 057 EF	10
5.80	93.0	57.0	281 058 E	10	281 058 EF	10
5.90	93.0	57.0	281 059 E	10	281 059 EF	10
6.00	93.0	57.0	281 060 E	10	281 060 EF	10
6.10	101.0	63.0	281 061 E	10	281 061 EF	10
6.20	101.0	63.0	281 062 E	10	281 062 EF	10
6.30	101.0	63.0	281 063 E	10	281 063 EF	10
6.40	101.0	63.0	281 064 E	10	281 064 EF	10
6.50	101.0	63.0	281 065 E	10	281 065 EF	10
6.60	101.0	63.0	281 066 E	10	281 066 EF	10
6.70	101.0	63.0	281 067 E	10	281 067 EF	10
6.80	109.0	69.0	281 068 E	10	281 068 EF	10
6.90	109.0	69.0	281 069 E	10	281 069 EF	10
7.00	109.0	69.0	281 070 E	10	281 070 EF	10
7.10	109.0	69.0	281 071 E	10	281 071 EF	10
7.20	109.0	69.0	281 072 E	10	281 072 EF	10
7.30	109.0	69.0	281 073 E	10	281 073 EF	10
7.40	109.0	69.0	281 074 E	10	281 074 EF	10
7.50	109.0	69.0	281 075 E	10	281 075 EF	10
7.60	117.0	75.0	281 076 E	10	281 076 EF	10
7.70	117.0	75.0	281 077 E	10	281 077 EF	10
7.80	117.0	75.0	281 078 E	10	281 078 EF	10
7.90	117.0	75.0	281 079 E	10	281 079 EF	10
8.00	117.0	75.0	281 080 E	10	281 080 EF	10
8.10	117.0	75.0	281 081 E	10	281 081 EF	10
8.20	117.0	75.0	281 082 E	10	281 082 EF	10
8.30	117.0	75.0	281 083 E	10	281 083 EF	10
8.40	117.0	75.0	281 084 E	10	281 084 EF	10
8.50	117.0	75.0	281 085 E	10	281 085 EF	10
8.60	125.0	81.0	281 086 E	10	281 086 EF	10
8.70	125.0	81.0	281 087 E	10	281 087 EF	10
8.80	125.0	81.0	281 088 E	10	281 088 EF	10
8.90	125.0	81.0	281 089 E	10	281 089 EF	10
9.00	125.0	81.0	281 090 E	10	281 090 EF	10
9.10	125.0	81.0	281 091 E	10	281 091 EF	10
9.20	125.0	81.0	281 092 E	10	281 092 EF	10
9.30	125.0	81.0	281 093 E	10	281 093 EF	10
9.40	125.0	81.0	281 094 E	10	281 094 EF	10
9.50	125.0	81.0	281 095 E	10	281 095 EF	10
9.60	133.0	87.0	281 096 E	10	281 096 EF	10
9.70	133.0	87.0	281 097 E	10	281 097 EF	10
9.80	133.0	87.0	281 098 E	10	281 098 EF	10
9.90	133.0	87.0	281 099 E	10	281 099 EF	10
10.00	133.0	87.0	281 100 E	10	281 100 EF	10
10.20	133.0	87.0	281 102 E	10	281 102 EF	10
10.50	133.0	87.0	281 105 E	5	281 105 EF	5
11.00	142.0	94.0	281 110 E	5	281 110 EF	5
11.50	142.0	94.0	281 115 E	5	281 115 EF	5
12.00	151.0	101.0	281 120 E	5	281 120 EF	5
12.50	151.0	101.0	281 125 E	5	281 125 EF	5
13.00	151.0	101.0	281 130 E	5	281 130 EF	5
13.50	160.0	108.0	281 135 E	5	281 135 EF	5
14.00	160.0	108.0	281 140 E	5	281 140 EF	5
14.50	169.0	114.0	281 145 E	5	281 145 EF	5
15.00	169.0	114.0	281 150 E	5	281 150 EF	5
15.50	178.0	120.0	281 155 E	5	281 155 EF	5
16.00	178.0	120.0	281 160 E	5	281 160 EF	5



		HSSE-Co 8	HSSE-Co 8 TiAlN
19 tfg./pcs.	Twist drill set DIN 338 type VA Ø 1.0 mm to 10.0 mm x 0.5 mm increasing	281 214 ERO	281 214 EFRO
25 tfg./pcs.	Twist drill set DIN 338 type VA Ø 1.0 mm to 13.0 mm x 0.5 mm increasing	281 215 ERO	281 215 EFRO



i

Coolants and lubricants

RUKO coolants and lubricants have an excellent release and cooling effect. They produce a high surface quality and increase tool life even with hard and brittle materials.

You will find the coolants and lubricants to match our range coolants and lubricants in our **chapter 14, page 303**.







Twist drill DIN 338 type VA, HSSE-Co 5



Powerful right-hand cutting high-performance drill with distinctive heat resistance. Ideal for drilling high-strength stainless, acid-resistant and heat-resistant steel



Packaging: plastic tube

Ø mm	L1 mm	L2 mm	HSSE-Co 5	
1.00	34.0	12.0	215 010	10
1.10	36.0	14.0	215 011	10
1.20	38.0	16.0	215 012	10
1.25	38.0	16.0	215 0125	10
1.30	38.0	16.0	215 013	10
1.40	40.0	18.0	215 014	10
1.50	40.0	18.0	215 015	10
1.60	43.0	20.0	215 016	10
1.70	43.0	20.0	215 017	10
1.75	46.0	22.0	215 0175	10
1.80	46.0	22.0	215 018	10
1.90	46.0	22.0	215 019	10
2.00	49.0	24.0	215 020	10
2.10	49.0	24.0	215 021	10
2.20	53.0	27.0	215 022	10
2.25	53.0	27.0	215 0225	10
2.30	53.0	27.0	215 023	10
2.40	57.0	30.0	215 024	10
2.50	57.0	30.0	215 025	10
2.60	57.0	30.0	215 026	10
2.70	61.0	33.0	215 027	10
2.75	61.0	33.0	215 0275	10
2.80	61.0	33.0	215 028	10
2.90	61.0	33.0	215 029	10
3.00	61.0	33.0	215 030	10
3.10	65.0	36.0	215 031	10
3.20	65.0	36.0	215 032	10
3.25	65.0	36.0	215 0325	10
3.30	65.0	36.0	215 033	10
3.40	70.0	39.0	215 034	10
3.50	70.0	39.0	215 035	10
3.60	70.0	39.0	215 036	10
3.70	70.0	39.0	215 037	10
3.75	70.0	39.0	215 0375	10
3.80	75.0	43.0	215 038	10
3.90	75.0	43.0	215 039	10
4.00	75.0	43.0	215 040	10
4.10	75.0	43.0	215 041	10
4.20	75.0	43.0	215 042	10
4.25	75.0	43.0	215 0425	10

Ø mm	L1 mm	L2 mm	HSSE-Co 5	
4.30	80.0	47.0	215 043	10
4.40	80.0	47.0	215 044	10
4.50	80.0	47.0	215 045	10
4.60	80.0	47.0	215 046	10
4.70	80.0	47.0	215 047	10
4.75	80.0	47.0	215 0475	10
4.80	86.0	52.0	215 048	10
4.90	86.0	52.0	215 049	10
5.00	86.0	52.0	215 050	10
5.10	86.0	52.0	215 051	10
5.20	86.0	52.0	215 052	10
5.25	86.0	52.0	215 0525	10
5.30	86.0	52.0	215 053	10
5.40	93.0	57.0	215 054	10
5.50	93.0	57.0	215 055	10
5.60	93.0	57.0	215 056	10
5.70	93.0	57.0	215 057	10
5.75	93.0	57.0	215 0575	10
5.80	93.0	57.0	215 058	10
5.90	93.0	57.0	215 059	10
6.00	93.0	57.0	215 060	10
6.10	101.0	63.0	215 061	10
6.20	101.0	63.0	215 062	10
6.25	101.0	63.0	215 0625	10
6.30	101.0	63.0	215 063	10
6.40	101.0	63.0	215 064	10
6.50	101.0	63.0	215 065	10
6.60	101.0	63.0	215 066	10
6.70	101.0	63.0	215 067	10
6.75	101.0	63.0	215 0675	10
6.80	109.0	69.0	215 068	10
6.90	109.0	69.0	215 069	10
7.00	109.0	69.0	215 070	10
7.10	109.0	69.0	215 071	10
7.20	109.0	69.0	215 072	10
7.25	109.0	69.0	215 0725	10
7.30	109.0	69.0	215 073	10
7.40	109.0	69.0	215 074	10
7.50	109.0	69.0	215 075	10
7.60	117.0	75.0	215 076	10

Ø mm	L1 mm	L2 mm	HSSE-Co 5	
7.70	117.0	75.0	215 077	10
7.75	117.0	75.0	215 0775	10
7.80	117.0	75.0	215 078	10
7.90	117.0	75.0	215 079	10
8.00	117.0	75.0	215 080	10
8.10	117.0	75.0	215 081	10
8.20	117.0	75.0	215 082	10
8.25	117.0	75.0	215 0825	10
8.30	117.0	75.0	215 083	10
8.40	117.0	75.0	215 084	10
8.50	117.0	75.0	215 085	10
8.60	125.0	81.0	215 086	10
8.70	125.0	81.0	215 087	10
8.75	125.0	81.0	215 0875	10
8.80	125.0	81.0	215 088	10
8.90	125.0	81.0	215 089	10
9.00	125.0	81.0	215 090	10
9.10	125.0	81.0	215 091	10
9.20	125.0	81.0	215 092	10
9.25	125.0	81.0	215 0925	10
9.30	125.0	81.0	215 093	10
9.40	125.0	81.0	215 094	10
9.50	125.0	81.0	215 095	10
9.60	133.0	87.0	215 096	10
9.70	133.0	87.0	215 097	10
9.75	133.0	87.0	215 0975	10
9.80	133.0	87.0	215 098	10
9.90	133.0	87.0	215 099	10
10.00	133.0	87.0	215 100	10
10.10	133.0	87.0	215 101	10
10.20	133.0	87.0	215 102	10
10.30	133.0	87.0	215 103	10
10.40	133.0	87.0	215 104	10
10.50	133.0	87.0	215 105	5
10.60	133.0	87.0	215 106	5
10.70	142.0	94.0	215 107	5
10.80	142.0	94.0	215 108	5

Ø mm	L1 mm	L2 mm	HSSE-Co 5	
10.90	142.0	94.0	215 109	5
11.00	142.0	94.0	215 110	5
11.10	142.0	94.0	215 111	5
11.20	142.0	94.0	215 112	5
11.30	142.0	94.0	215 113	5
11.40	142.0	94.0	215 114	5
11.50	142.0	94.0	215 115	5
11.60	142.0	94.0	215 116	5
11.70	142.0	94.0	215 117	5
11.80	142.0	94.0	215 118	5
11.90	151.0	101.0	215 119	5
12.00	151.0	101.0	215 120	5
12.10	151.0	101.0	215 121	5
12.20	151.0	101.0	215 122	5
12.30	151.0	101.0	215 123	5
12.40	151.0	101.0	215 124	5
12.50	151.0	101.0	215 125	5
12.60	151.0	101.0	215 126	5
12.70	151.0	101.0	215 127	5
12.80	151.0	101.0	215 128	5
12.90	151.0	101.0	215 129	5
13.00	151.0	101.0	215 130	5
13.50	160.0	108.0	215 135	5
14.00	160.0	108.0	215 140	5
14.50	169.0	114.0	215 145	5
15.00	169.0	114.0	215 150	5
15.50	178.0	120.0	215 155	5
16.00	178.0	120.0	215 160	5
16.50	184.0	125.0	215 165	1
17.00	184.0	125.0	215 170	1
17.50	191.0	130.0	215 175	1
18.00	191.0	130.0	215 180	1
18.50	198.0	135.0	215 185	1
19.00	198.0	135.0	215 190	1
19.50	205.0	140.0	215 195	1
20.00	205.0	140.0	215 210	1

		HSSE-Co 5
19 tfg./pcs.	Twist drill set DIN 338 type VA Ø 1.0 mm to 10.0 mm x 0.5 mm increasing	215 214 RO
24 tfg./pcs.	Twist drill set DIN 338 type VA Ø 1.0 mm to 10.5 mm x 0.5 mm increasing + 3.3 / 4.2 / 6.8 / 10.2 mm	215 216 RO
25 tfg./pcs.	Twist drill set DIN 338 type VA Ø 1.0 mm to 13.0 mm x 0.5 mm increasing	215 215 RO
41 tfg./pcs.	Twist drill set DIN 338 type VA Ø 6.0 mm to 10.0 mm x 0.1 mm increasing	215 218 RO
50 tfg./pcs.	Twist drill set DIN 338 type VA Ø 1.0 mm to 5.9 mm x 0.1 mm increasing	215 217 RO



215 214 RO



215 216 RO



215 218 RO



215 217 RO

91 tfg./pcs.	Twist drill set in workbench stand Ø 1.0 mm to 10.0 mm x 0.1 mm increasing	215 223
170 tfg./pcs.	Twist drill set in magazine 10 pieces each Ø 1.0 - 8.0 mm x 0.5 mm increasing 5 pieces each Ø 8.5 - 10.0 mm x 0.5 mm increasing	215 200 RO
570 tfg./pcs.	Drill cabinet, equipped 50 pieces each Ø 1.0 - 2.5 mm x 0.5 mm increasing 30 pieces each Ø 3.0 - 5.5 mm x 0.5 mm increasing 20 pieces each Ø 6.0 - 7.5 mm x 0.5 mm increasing 10 pieces each Ø 8.0 - 13.0 mm x 0.5 mm increasing	215 208
	Drill cabinet empty Dimensions: H1: 23.0 cm. L1: 37.0 cm. D1: 9.5 cm. T2: 20.0 cm Ø 1.0 mm to 13.0 mm x 0.5 mm increasing	205 208 L
	Drill cabinet empty Dimensions: H1: 46.5 cm. L1: 39.0 cm. D1: 9.5 cm. T2: 20.0 cm Ø 1.0 mm to 10.0 mm x 0.1 mm increasing Ø 10.5 mm to 13.0 mm x 0.5 mm increasing	205 2081 L



215 223



215 200 RO



205 208 L



Twist drill DIN 338 type VA, HSSE-Co 5 – inch dimensions



Powerful right-hand cutting high-performance drill with distinctive heat resistance and reinforced drill core. Ideal for drilling high-strength stainless, acid-resistant and heat-resistant steel.



Inch Size



Packaging: plastic tube

Ø inch	Ø mm	L1 inch	L2 inch	HSSE-Co 5	
1/16	1,59	1 7/8	7/8	215 801	10
5/64	1,98	2	1	215 802	10
3/32	2,38	2 1/4	1 1/4	215 803	10
7/64	2,78	2 5/8	1 1/2	215 804	10
1/8	3,18	2 3/4	1 5/8	215 805	10
9/64	3,57	2 7/8	1 3/4	215 806	10
5/32	3,97	3 1/8	2	215 807	10
11/64	4,37	3 1/4	2 1/8	215 808	10
3/16	4,76	3 1/2	2 5/16	215 809	10
13/64	5,16	3 5/8	2 7/16	215 810	10
7/32	5,56	3 3/4	2 1/2	215 811	10
15/64	5,95	3 7/8	2 5/8	215 812	10
1/4	6,35	4	2 3/4	215 813	10
17/64	6,75	4 1/8	2 7/8	215 814	10
9/32	7,14	4 1/4	2 15/16	215 815	10

Ø inch	Ø mm	L1 inch	L2 inch	HSSE-Co 5	
19/64	7,54	4 3/8	3 1/16	215 816	10
5/16	7,94	4 1/2	3 3/16	215 817	10
21/64	8,33	4 5/8	3 5/16	215 818	10
11/32	8,73	4 3/4	3 7/16	215 819	10
23/64	9,13	4 7/8	3 1/2	215 820	10
3/8	9,53	5	3 5/8	215 821	10
25/64	9,92	5 1/8	3 3/4	215 822	10
13/32	10,32	5 1/4	3 7/8	215 823	10
27/64	10,72	5 3/8	3 15/16	215 824	5
7/16	11,11	5 1/2	4 1/16	215 825	5
29/64	11,51	5 5/8	4 3/16	215 826	5
15/32	11,91	5 3/4	4 5/16	215 827	5
31/64	12,30	5 7/8	4 3/8	215 828	5
1/2	12,70	6	4 1/2	215 829	5

		HSSE-Co 5
21 tq. pcs.	Twist drill set DIN 338 type VA Ø 1/16" to 3/8" x 1/64" increasing	215 850 RO
29 tq. pcs.	Twist drill set DIN 338 type VA Ø 1/16" to 1/2" x 1/64" increasing	215 851 RO





Twist drill DIN 338 type UNI, HSSE-Co 5



- The trihedral shank ensures excellent fixation in the drill chuck with little effort.
- The shank also ensures optimum power transmission. No spinning of the drill bit!
- The 135° high-performance cutting edge ensures very high centering accuracy, especially for hand-held applications with the cordless drill driver. The cutting edge prevents slipping when drilling curved surfaces.
- Increased battery life by reducing cutting forces.
- The black bevel increases wear resistance and prevents cold welding and built-up edges.
- The 40° helix angle enables perfect and fast chip evacuation and ensures high cutting speeds with increased stability and accuracy.

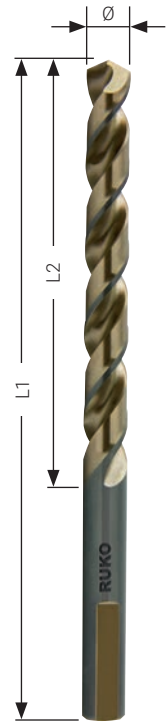

Application tip

This high-performance twist drill was specially developed for portable use in drills and cordless drill drivers. (Best performance up to 5.0 mm material thickness).



Packaging: plastic tube

Ø mm	L1 mm	L2 mm	HSSE-Co 5	
1.00	34.0	12.0	228 010	10
1.50	40.0	18.0	228 015	10
2.00	49.0	24.0	228 020	10
2.50	57.0	30.0	228 025	10
3.00	61.0	33.0	228 030	10
3.30	65.0	36.0	228 033	10
3.50	70.0	39.0	228 035	10
4.00	75.0	43.0	228 040	10
4.20	75.0	43.0	228 042	10
4.50	80.0	47.0	228 045	10
5.00	86.0	52.0	228 050	10
5.50	93.0	57.0	228 055	10
6.00	93.0	57.0	228 060	10
6.50	101.0	63.0	228 065	10
6.80	109.0	69.0	228 068	10

Ø mm	L1 mm	L2 mm	HSSE-Co 5	
7.00	109.0	69.0	228 070	10
7.50	109.0	69.0	228 075	10
8.00	117.0	75.0	228 080	10
8.50	117.0	75.0	228 085	10
9.00	125.0	81.0	228 090	10
9.50	125.0	81.0	228 095	10
10.00	133.0	87.0	228 100	10
10.20	133.0	87.0	228 102	10
10.50	133.0	87.0	228 105	5
11.00	142.0	94.0	228 110	5
11.50	142.0	94.0	228 115	5
12.00	151.0	101.0	228 120	5
12.50	151.0	101.0	228 125	5
13.00	151.0	101.0	228 130	5

		HSSE-Co 5
19 tlg./pcs.	Twist drill set DIN 338 type UNI Ø 1.0 mm to 10.0 mm x 0.5 mm increasing	228 214 R0
25 tlg./pcs.	Twist drill set DIN 338 type UNI Ø 1.0 mm to 13.0 mm x 0.5 mm increasing	228 215 R0



228 214 R0



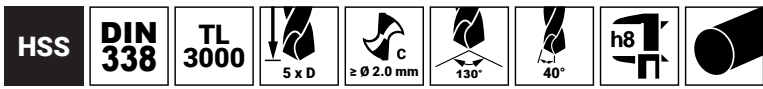

Twist drill DIN 338 TL 3000, HSS

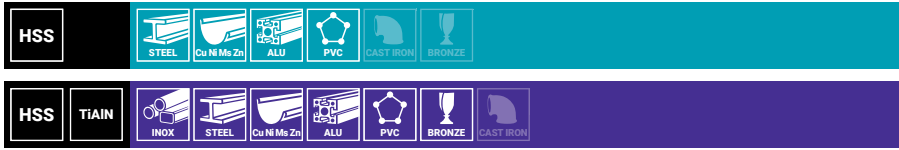

Highly stable multirange drill with outstanding heat resistance, a reinforced drill core and a parabolic flute for ideal chip removal. Ideal for drilling medium and long-chipping materials. Thanks to its thick core and the special flute with a rounded rear edge, this drill is best suited for high-performance use. It covers types N, H and W for a wide range of applications.



Packaging: plastic tube

Ø mm	L1 mm	L2 mm	HSS TiAlN	
1.00	34.0	12.0	258 010 F	10
1.50	40.0	18.0	258 015 F	10
2.00	49.0	24.0	258 020 F	10
2.50	57.0	30.0	258 025 F	10
3.00	61.0	33.0	258 030 F	10
3.30	65.0	36.0	258 033 F	10
3.50	70.0	39.0	258 035 F	10
4.00	75.0	43.0	258 040 F	10
4.20	75.0	43.0	258 042 F	10
4.50	80.0	47.0	258 045 F	10
5.00	86.0	52.0	258 050 F	10
5.50	93.0	57.0	258 055 F	10
6.00	93.0	57.0	258 060 F	10
6.50	101.0	63.0	258 065 F	10
6.80	109.0	69.0	258 068 F	10
7.00	109.0	69.0	258 070 F	10
7.50	109.0	69.0	258 075 F	10
8.00	117.0	75.0	258 080 F	10
8.50	117.0	75.0	258 085 F	10
9.00	125.0	81.0	258 090 F	10
9.50	125.0	81.0	258 095 F	10
10.00	133.0	87.0	258 100 F	10
10.20	133.0	87.0	258 102 F	10
10.50	133.0	87.0	258 105 F	5
11.00	142.0	94.0	258 110 F	5
11.50	142.0	94.0	258 115 F	5
12.00	151.0	101.0	258 120 F	5
12.50	151.0	101.0	258 125 F	5
13.00	151.0	101.0	258 130 F	5
13.50	160.0	108.0	258 135 F	5
14.00	160.0	108.0	258 140 F	5
14.50	169.0	114.0	258 145 F	5
15.00	169.0	114.0	258 150 F	5
15.50	178.0	120.0	258 155 F	5
16.00	178.0	120.0	258 160 F	5

HSS	
258 010	10
258 015	10
258 020	10
258 025	10
258 030	10
258 033	10
258 035	10
258 040	10
258 042	10
258 045	10
258 050	10
258 055	10
258 060	10
258 065	10
258 068	10
258 070	10
258 075	10
258 080	10
258 085	10
258 090	10
258 095	10
258 100	10
258 102	10
258 105	5
258 110	5
258 115	5
258 120	5
258 125	5
258 130	5
258 135	5
258 140	5
258 145	5
258 150	5
258 155	5
258 160	5

		HSS TiAIN	HSS
19 fig./pcs.	Twist drill set DIN 338 TL 3000, HSS Ø 1.0 mm to 10.0 mm x 0.5 mm increasing	258 214 FRO	258 214 RO
25 fig./pcs.	Twist drill set DIN 338 TL 3000, HSS Ø 1.0 mm to 13.0 mm x 0.5 mm increasing	258 215 FRO	258 215 RO



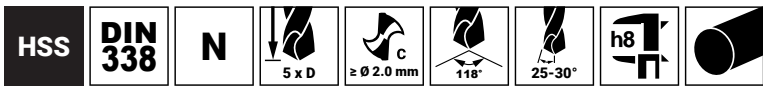

Twist drill DIN 338 type N, HSS + TiN

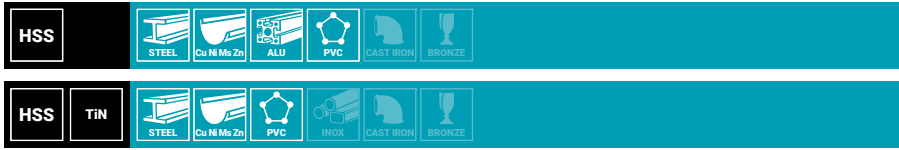

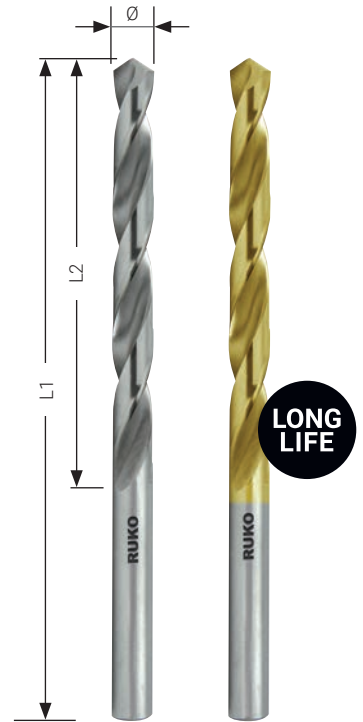

High-performance ground standard twist drill made from high speed steel. The fully ground twist drill has a precise concentricity. Thanks to the split point, this drill has good centering properties and requires little pressure.





Packaging: plastic tube

Ø mm	L1 mm	L2 mm	HSS		HSS TiN	
0.30	19.0	3.0	214 003	10	250 003 T	10
0.40	20.0	5.0	214 004	10	250 004 T	10
0.50	22.0	6.0	214 005	10	250 005 T	10
0.60	24.0	7.0	214 006	10	250 006 T	10
0.70	28.0	9.0	214 007	10	250 007 T	10
0.80	30.0	10.0	214 008	10	250 008 T	10
0.90	32.0	11.0	214 009	10	250 009 T	10
1.00	34.0	12.0	214 010	10	250 010 T	10
1.10	36.0	14.0	214 011	10	250 011 T	10
1.20	38.0	16.0	214 012	10	250 012 T	10
1.25	38.0	16.0	214 0125	10	250 0125 T	10
1.30	38.0	16.0	214 013	10	250 013 T	10
1.40	40.0	18.0	214 014	10	250 014 T	10
1.50	40.0	18.0	214 015	10	250 015 T	10
1.60	43.0	20.0	214 016	10	250 016 T	10
1.70	43.0	20.0	214 017	10	250 017 T	10
1.75	46.0	20.0	214 0175	10	250 0175 T	10
1.80	46.0	22.0	214 018	10	250 018 T	10
1.90	46.0	22.0	214 019	10	250 019 T	10
2.00	49.0	24.0	214 020	10	250 020 T	10
2.10	49.0	24.0	214 021	10	250 021 T	10
2.20	53.0	27.0	214 022	10	250 022 T	10
2.25	53.0	27.0	214 0225	10	250 0225 T	10
2.30	53.0	27.0	214 023	10	250 023 T	10
2.40	57.0	30.0	214 024	10	250 024 T	10
2.50	57.0	30.0	214 025	10	250 025 T	10
2.60	57.0	30.0	214 026	10	250 026 T	10
2.70	61.0	33.0	214 027	10	250 027 T	10
2.75	61.0	33.0	214 0275	10	250 0275 T	10
2.80	61.0	33.0	214 028	10	250 028 T	10
2.90	61.0	33.0	214 029	10	250 029 T	10
3.00	61.0	33.0	214 030	10	250 030 T	10
3.10	65.0	36.0	214 031	10	250 031 T	10
3.20	65.0	36.0	214 032	10	250 032 T	10
3.25	65.0	36.0	214 0325	10	250 0325 T	10
3.30	65.0	36.0	214 033	10	250 033 T	10
3.40	70.0	39.0	214 034	10	250 034 T	10
3.50	70.0	39.0	214 035	10	250 035 T	10
3.60	70.0	39.0	214 036	10	250 036 T	10
3.70	70.0	39.0	214 037	10	250 037 T	10

∅ mm	L1 mm	L2 mm	HSS		HSS TiN	
3.75	70.0	39.0	214 0375	10	250 0375 T	10
3.80	75.0	43.0	214 038	10	250 038 T	10
3.90	75.0	43.0	214 039	10	250 039 T	10
4.00	75.0	43.0	214 040	10	250 040 T	10
4.10	75.0	43.0	214 041	10	250 041 T	10
4.20	75.0	43.0	214 042	10	250 042 T	10
4.25	75.0	43.0	214 0425	10	250 0425 T	10
4.30	80.0	47.0	214 043	10	250 043 T	10
4.40	80.0	47.0	214 044	10	250 044 T	10
4.50	80.0	47.0	214 045	10	250 045 T	10
4.60	80.0	47.0	214 046	10	250 046 T	10
4.70	80.0	47.0	214 047	10	250 047 T	10
4.75	80.0	47.0	214 0475	10	250 0475 T	10
4.80	86.0	52.0	214 048	10	250 048 T	10
4.90	86.0	52.0	214 049	10	250 049 T	10
5.00	86.0	52.0	214 050	10	250 050 T	10
5.10	86.0	52.0	214 051	10	250 051 T	10
5.20	86.0	52.0	214 052	10	250 052 T	10
5.25	86.0	52.0	214 0525	10	250 0525 T	10
5.30	86.0	52.0	214 053	10	250 053 T	10
5.40	93.0	57.0	214 054	10	250 054 T	10
5.50	93.0	57.0	214 055	10	250 055 T	10
5.60	93.0	57.0	214 056	10	250 056 T	10
5.70	93.0	57.0	214 057	10	250 057 T	10
5.75	93.0	57.0	214 0575	10	250 0575 T	10
5.80	93.0	57.0	214 058	10	250 058 T	10
5.90	93.0	57.0	214 059	10	250 059 T	10
6.00	93.0	57.0	214 060	10	250 060 T	10
6.10	101.0	63.0	214 061	10	250 061 T	10
6.20	101.0	63.0	214 062	10	250 062 T	10
6.25	101.0	63.0	214 0625	10	250 0625 T	10
6.30	101.0	63.0	214 063	10	250 063 T	10
6.40	101.0	63.0	214 064	10	250 064 T	10
6.50	101.0	63.0	214 065	10	250 065 T	10
6.60	101.0	63.0	214 066	10	250 066 T	10
6.70	101.0	63.0	214 067	10	250 067 T	10
6.75	101.0	63.0	214 0675	10	250 0675 T	10
6.80	109.0	69.0	214 068	10	250 068 T	10
6.90	109.0	69.0	214 069	10	250 069 T	10
7.00	109.0	69.0	214 070	10	250 070 T	10
7.10	109.0	69.0	214 071	10	250 071 T	10
7.20	109.0	69.0	214 072	10	250 072 T	10
7.25	109.0	69.0	214 0725	10	250 0725 T	10
7.30	109.0	69.0	214 073	10	250 073 T	10
7.40	109.0	69.0	214 074	10	250 074 T	10
7.50	109.0	69.0	214 075	10	250 075 T	10
7.60	117.0	75.0	214 076	10	250 076 T	10
7.70	117.0	75.0	214 077	10	250 077 T	10
7.75	117.0	75.0	214 0775	10	250 0775 T	10
7.80	117.0	75.0	214 078	10	250 078 T	10
7.90	117.0	75.0	214 079	10	250 079 T	10
8.00	117.0	75.0	214 080	10	250 080 T	10
8.10	117.0	75.0	214 081	10	250 081 T	10
8.20	117.0	75.0	214 082	10	250 082 T	10
8.25	117.0	75.0	214 0825	10	250 0825 T	10
8.30	117.0	75.0	214 083	10	250 083 T	10
8.40	117.0	75.0	214 084	10	250 084 T	10
8.50	117.0	75.0	214 085	10	250 085 T	10
8.60	125.0	81.0	214 086	10	250 086 T	10
8.70	125.0	81.0	214 087	10	250 087 T	10
8.75	125.0	81.0	214 0875	10	250 0875 T	10
8.80	125.0	81.0	214 088	10	250 088 T	10
8.90	125.0	81.0	214 089	10	250 089 T	10
9.00	125.0	81.0	214 090	10	250 090 T	10
9.10	125.0	81.0	214 091	10	250 091 T	10
9.20	125.0	81.0	214 092	10	250 092 T	10
9.25	125.0	81.0	214 0925	10	250 0925 T	10
9.30	125.0	81.0	214 093	10	250 093 T	10
9.40	125.0	81.0	214 094	10	250 094 T	10
9.50	125.0	81.0	214 095	10	250 095 T	10
9.60	133.0	87.0	214 096	10	250 096 T	10
9.70	133.0	87.0	214 097	10	250 097 T	10
9.75	133.0	87.0	214 0975	10	250 0975 T	10
9.80	133.0	87.0	214 098	10	250 098 T	10



Ø mm	L1 mm	L2 mm	HSS		HSS TiN	
9.90	133.0	87.0	214 099	10	250 099 T	10
10.00	133.0	87.0	214 100	10	250 100 T	10
10.10	133.0	87.0	214 101	10	250 101 T	10
10.20	133.0	87.0	214 102	10	250 102 T	10
10.30	133.0	87.0	214 103	10	250 103 T	10
10.40	133.0	87.0	214 104	10	250 104 T	10
10.50	133.0	87.0	214 105	5	250 105 T	5
10.60	133.0	87.0	214 106	5	250 106 T	5
10.70	142.0	94.0	214 107	5	250 107 T	5
10.80	142.0	94.0	214 108	5	250 108 T	5
10.90	142.0	94.0	214 109	5	250 109 T	5
11.00	142.0	94.0	214 110	5	250 110 T	5
11.10	142.0	94.0	214 111	5	250 111 T	5
11.20	142.0	94.0	214 112	5	250 112 T	5
11.30	142.0	94.0	214 113	5	250 113 T	5
11.40	142.0	94.0	214 114	5	250 114 T	5
11.50	142.0	94.0	214 115	5	250 115 T	5
11.60	142.0	94.0	214 116	5	250 116 T	5
11.70	142.0	94.0	214 117	5	250 117 T	5
11.80	142.0	94.0	214 118	5	250 118 T	5
11.90	151.0	101.0	214 119	5	250 119 T	5
12.00	151.0	101.0	214 120	5	250 120 T	5
12.10	151.0	101.0	214 121	5	250 121 T	5
12.20	151.0	101.0	214 122	5	250 122 T	5
12.30	151.0	101.0	214 123	5	250 123 T	5
12.40	151.0	101.0	214 124	5	250 124 T	5
12.50	151.0	101.0	214 125	5	250 125 T	5
12.60	151.0	101.0	214 126	5	250 126 T	5
12.70	151.0	101.0	214 127	5	250 127 T	5
12.80	151.0	101.0	214 128	5	250 128 T	5
12.90	151.0	101.0	214 129	5	250 129 T	5
13.00	151.0	101.0	214 130	5	250 130 T	5
13.50	160.0	108.0	214 135	5	250 135 T	5
14.00	160.0	108.0	214 140	5	250 140 T	5
14.50	169.0	114.0	214 145	5	250 145 T	5
15.00	169.0	114.0	214 150	5	250 150 T	5
15.50	178.0	120.0	214 155	5	250 155 T	5
16.00	178.0	120.0	214 160	5	250 160 T	5
16.50	184.0	125.0	214 165	1		
17.00	184.0	125.0	214 170	1		
17.50	191.0	130.0	214 175	1		
18.00	191.0	130.0	214 180	1		
18.50	198.0	135.0	214 185	1		
19.00	198.0	135.0	214 190	1		
19.50	205.0	140.0	214 195	1		
20.00	205.0	140.0	214 201	1		

		HSS
19 tfg./pcs.	Twist drill DIN 338 type N. HSS Ø 1.0 mm to 10.0 mm x 0.5 mm increasing	214 214 R0
24 tfg./pcs.	Twist drill DIN 338 type N. HSS Ø 1.0 mm to 10.5 mm x 0.5 mm increasing + 3.3 / 4.2 / 6.8 / 10.2 mm	214 216 R0
25 tfg./pcs.	Twist drill DIN 338 type N. HSS Ø 1.0 mm to 13.0 mm x 0.5 mm increasing	214 215 R0
41 tfg./pcs.	Twist drill DIN 338 type N. HSS Ø 6.0 mm to 10.0 mm x 0.1 mm increasing	214 218 R0
50 tfg./pcs.	Twist drill DIN 338 type N. HSS Ø 1.0 mm to 5.9 mm x 0.1 mm increasing	214 217 R0



214 214 R0

		HSS TiN
19 tq./pcs.	Twist drill DIN 338 type N. HSS-TiN Ø 1.0 mm to 10.0 mm x 0.5 mm increasing	250 214 TRO
25 tq./pcs.	Twist drill DIN 338 type N. HSS-TiN Ø 1.0 mm to 13.0 mm x 0.5 mm increasing	250 215 TRO



250 214 TRO

LONG
LIFE

01

		HSS
91 tq./pcs.	Twist drill set in workbench stand Ø 1.0 mm to 10.0 mm x 0.1 mm increasing	214 223
170 tq./pcs.	Twist drill set in magazine 10 pieces each Ø 1.0 - 8.0 mm x 0.5 mm increasing 5 pieces each Ø 8.5 - 10.0 mm x 0.5 mm increasing	214 200 RO
570 tq./pcs.	Drill cabinet, equipped 50 pieces each Ø 1.0 - 2.5 mm x 0.5 mm increasing 30 pieces each Ø 3.0 - 5.5 mm x 0.5 mm increasing 20 pieces each Ø 6.0 - 7.5 mm x 0.5 mm increasing 10 pieces each Ø 8.0 - 13.0 mm x 0.5 mm increasing	214 208



214 223



214 200 RO



214 208
(Equipment not shown)

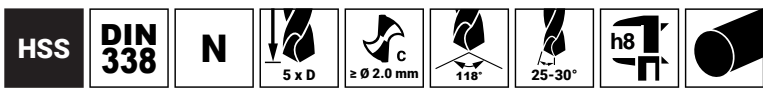

**Twist drill DIN 338 type N,
HSS – inch dimensions**



High-performance ground standard twist drill made from high speed steel. The fully ground twist drill has a precise concentricity. Thanks to the split point, this drill has good centering properties and requires little pressure.

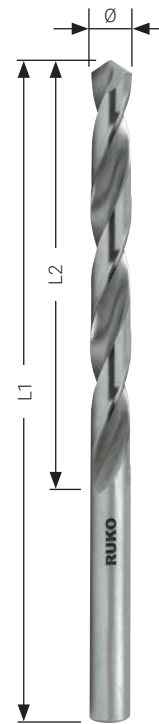

Inch Size

Packaging: plastic tube

Ø inch	Ø mm	L1 inch	L2 inch	HSS	
1/16	1,59	1 7/8	7/8	214 801	10
5/64	1,98	2	1	214 802	10
3/32	2,38	2 1/4	1 1/4	214 803	10
7/64	2,78	2 5/8	1 1/2	214 804	10
1/8	3,18	2 3/4	1 5/8	214 805	10
9/64	3,57	2 7/8	1 3/4	214 806	10
5/32	3,97	3 1/8	2	214 807	10
11/64	4,37	3 1/4	2 1/8	214 808	10
3/16	4,76	3 1/2	2 5/16	214 809	10
13/64	5,16	3 5/8	2 7/16	214 810	10
7/32	5,56	3 3/4	2 1/2	214 811	10
15/64	5,95	3 7/8	2 5/8	214 812	10
1/4	6,35	4	2 3/4	214 813	10
17/64	6,75	4 1/8	2 7/8	214 814	10
9/32	7,14	4 1/4	2 15/16	214 815	10

Ø inch	Ø mm	L1 inch	L2 inch	HSS	
19/64	7,54	4 3/8	3 1/16	214 816	10
5/16	7,94	4 1/2	3 3/16	214 817	10
21/64	8,33	4 5/8	3 5/16	214 818	10
11/32	8,73	4 3/4	3 7/16	214 819	10
23/64	9,13	4 7/8	3 1/2	214 820	10
3/8	9,53	5	3 5/8	214 821	10
25/64	9,92	5 1/8	3 3/4	214 822	10
13/32	10,32	5 1/4	3 7/8	214 823	10
27/64	10,72	5 3/8	3 15/16	214 824	5
7/16	11,11	5 1/2	4 1/16	214 825	5
29/64	11,51	5 5/8	4 3/16	214 826	5
15/32	11,91	5 3/4	4 5/16	214 827	5
31/64	12,30	5 7/8	4 3/8	214 828	5
1/2	12,70	6	4 1/2	214 829	5

		HSS
21 11g./pcs.	Twist drill set DIN 338 type N Ø 1/16" to 3/8" x 1/64" increasing	214 850 RO
29 11g./pcs.	Twist drill set DIN 338 type N Ø 1/16" to 1/2" x 1/64" increasing	214 851 RO



214 850 RO

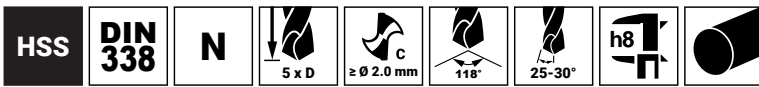

Twist drill DIN 338 type N, HSS TiN – inch dimensions



High-performance ground standard twist drill made from high speed steel. The fully ground twist drill has a precise concentricity. Thanks to the split point, this drill has good centering properties and requires little pressure.



Packaging: plastic tube

Ø inch	Ø mm	L1 inch	L2 inch	HSS TiN	
1/16	1,59	1 7/8	7/8	250 801 T	10
5/64	1,98	2	1	250 802 T	10
3/32	2,38	2 1/4	1 1/4	250 803 T	10
7/64	2,78	2 5/8	1 1/2	250 804 T	10
1/8	3,18	2 3/4	1 5/8	250 805 T	10
9/64	3,57	2 7/8	1 3/4	250 806 T	10
5/32	3,97	3 1/8	2	250 807 T	10
11/64	4,37	3 1/4	2 1/8	250 808 T	10
3/16	4,76	3 1/2	2 5/16	250 809 T	10
13/64	5,16	3 5/8	2 7/16	250 810 T	10
7/32	5,56	3 3/4	2 1/2	250 811 T	10
15/64	5,95	3 7/8	2 5/8	250 812 T	10
1/4	6,35	4	2 3/4	250 813 T	10
17/64	6,75	4 1/8	2 7/8	250 814 T	10
9/32	7,14	4 1/4	2 15/16	250 815 T	10

Ø inch	Ø mm	L1 inch	L2 inch	HSS TiN	
19/64	7,54	4 3/8	3 1/16	250 816 T	10
5/16	7,94	4 1/2	3 3/16	250 817 T	10
21/64	8,33	4 5/8	3 5/16	250 818 T	10
11/32	8,73	4 3/4	3 7/16	250 819 T	10
23/64	9,13	4 7/8	3 1/2	250 820 T	10
3/8	9,53	5	3 5/8	250 821 T	10
25/64	9,92	5 1/8	3 3/4	250 822 T	10
13/32	10,32	5 1/4	3 7/8	250 823 T	10
27/64	10,72	5 3/8	3 15/16	250 824 T	5
7/16	11,11	5 1/2	4 1/16	250 825 T	5
29/64	11,51	5 5/8	4 3/16	250 826 T	5
15/32	11,91	5 3/4	4 5/16	250 827 T	5
31/64	12,30	5 7/8	4 3/8	250 828 T	5
1/2	12,70	6	4 1/2	250 829 T	5

		HSS TiN
21 tfg./pcs.	Twist drill set DIN 338 type N, HSS-TiN Ø 1/16" to 3/8" x 1/64" increasing	250 850 TRO
29 tfg./pcs.	Spiralbohrer-Satz DIN 338 Typ N, HSS-TiN Ø 1/16" bis 1/2" x 1/64" increasing	250 851 TRO



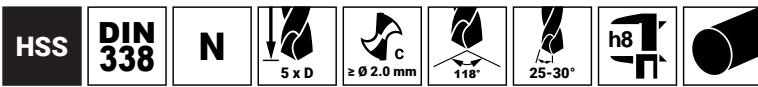

Twist drill DIN 338 type N, HSS-G with TiN tip coating



High-performance ground standard twist drill made from high speed steel. The fully ground twist drill has a precise concentricity. Thanks to the split point, this drill has good centring properties and requires little pressure.

The titanium nitride coating is a universally usable standard coating. It has a 300-400 % longer service life than non-coated materials. Cooling is recommended.

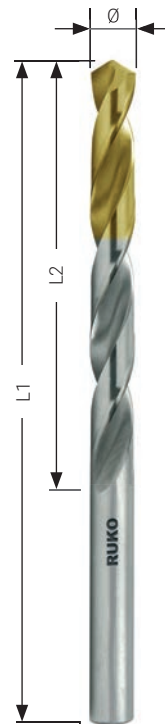

Packaging: plastic tube

Ø mm	L1 mm	L2 mm	HSS TiN	
1,00	34,0	12,0	2501 010 T	10
1,50	40,0	18,0	2501 015 T	10
1,60	43,0	20,0	2501 016 T	10
2,00	49,0	24,0	2501 020 T	10
2,10	49,0	24,0	2501 021 T	10
2,50	57,0	30,0	2501 025 T	10
3,00	61,0	33,0	2501 030 T	10
3,30	65,0	36,0	2501 033 T	10
3,50	70,0	39,0	2501 035 T	10
4,00	75,0	43,0	2501 040 T	10
4,20	75,0	43,0	2501 042 T	10
4,50	80,0	47,0	2501 045 T	10
5,00	86,0	52,0	2501 050 T	10
5,50	93,0	57,0	2501 055 T	10
6,00	93,0	57,0	2501 060 T	10
6,50	101,0	63,0	2501 065 T	10

Ø mm	L1 mm	L2 mm	HSS TiN	
6,80	109,0	69,0	2501 068 T	10
7,00	109,0	69,0	2501 070 T	10
7,50	109,0	69,0	2501 075 T	10
8,00	117,0	75,0	2501 080 T	10
8,50	117,0	75,0	2501 085 T	10
9,00	125,0	81,0	2501 090 T	10
9,50	125,0	81,0	2501 095 T	10
10,00	133,0	87,0	2501 100 T	10
10,20	133,0	87,0	2501 102 T	10
10,50	133,0	87,0	2501 105 T	5
11,00	142,0	94,0	2501 110 T	5
11,50	142,0	94,0	2501 115 T	5
12,00	151,0	101,0	2501 120 T	5
12,50	151,0	101,0	2501 125 T	5
13,00	151,0	101,0	2501 130 T	5

		HSS TiN
19 tfg./pcs.	Twist drill set DIN 338 type N Ø 1.0 mm to 10.0 mm x 0.5 mm increasing	2501 214 TRO
25 tfg./pcs.	Twist drill set DIN 338 type N Ø 1.0 mm to 13.0 mm x 0.5 mm increasing	2501 215 TRO



2501 214 TRO

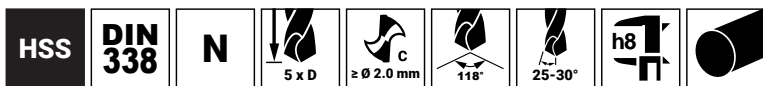

Twist drill DIN 338 type N, HSS – left-hand cutting



High-performance, ground twist drill made from high-speed steel. The fully ground twist drill has precise concentricity.



Application tip

This left-hand cutting twist drill was specially developed for portable use in power drills and cordless drill drivers. For drilling out broken screws and bolts.

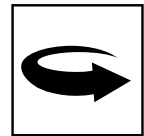
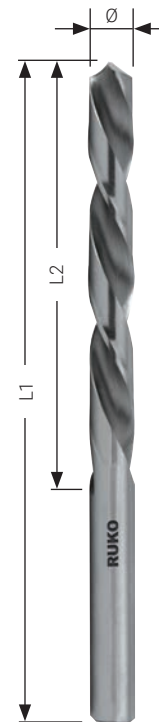

Packaging: plastic tube

Ø mm	L1 mm	L2 mm	HSS	
1.00	34.0	12.0	214 010 Li	10
1.50	40.0	18.0	214 015 Li	10
2.00	49.0	24.0	214 020 Li	10
2.50	57.0	30.0	214 025 Li	10
3.00	61.0	33.0	214 030 Li	10
3.20	65.0	36.0	214 032 Li	10
3.50	70.0	39.0	214 035 Li	10
4.00	75.0	43.0	214 040 Li	10
4.20	75.0	43.0	214 042 Li	10
4.50	80.0	47.0	214 045 Li	10
4.80	86.0	52.0	214 048 Li	10
5.00	86.0	52.0	214 050 Li	10
5.50	93.0	57.0	214 055 Li	10
6.00	93.0	57.0	214 060 Li	10

Ø mm	L1 mm	L2 mm	HSS	
6.50	101.0	63.0	214 065 Li	10
7.00	109.0	69.0	214 070 Li	10
7.50	109.0	69.0	214 075 Li	10
8.00	117.0	75.0	214 080 Li	10
8.50	117.0	75.0	214 085 Li	10
9.00	125.0	81.0	214 090 Li	10
9.50	125.0	81.0	214 095 Li	10
10.00	133.0	87.0	214 100 Li	10
10.50	133.0	87.0	214 105 Li	5
11.00	142.0	94.0	214 110 Li	5
11.50	142.0	94.0	214 115 Li	5
12.00	151.0	101.0	214 120 Li	5
12.50	151.0	101.0	214 125 Li	5
13.00	151.0	101.0	214 130 Li	5

		HSS
19 tfg./pcs.	Twist drill set DIN 338 type N Ø 1.0 mm to 10.0 mm x 0.5 mm increasing	214 214 LiRO
25 tfg./pcs.	Twist drill set DIN 338 type N Ø 1.0 mm to 13.0 mm x 0.5 mm increasing	214 215 LiRO





Twist drill DIN 338 type N, HSS-R



High-performance ground standard twist drill made from high speed steel. The fully ground twist drill has a precise concentricity. Thanks to the split point, this drill has good centring properties and requires little pressure.



Packaging: plastic tube

Ø mm	L1 mm	L2 mm	HSS-R	
0.30	19.0	3.0	201 003	10
0.40	20.0	5.0	201 004	10
0.50	22.0	6.0	201 005	10
0.60	24.0	7.0	201 006	10
0.70	28.0	9.0	201 007	10
0.80	30.0	10.0	201 008	10
0.90	32.0	11.0	201 009	10
1.00	34.0	12.0	201 010	10
1.10	36.0	14.0	201 011	10
1.20	38.0	16.0	201 012	10
1.25	38.0	16.0	201 0125	10
1.30	38.0	16.0	201 013	10
1.40	40.0	18.0	201 014	10
1.50	40.0	18.0	201 015	10
1.60	43.0	20.0	201 016	10
1.70	43.0	20.0	201 017	10
1.75	46.0	20.0	201 0175	10
1.80	46.0	22.0	201 018	10
1.90	46.0	22.0	201 019	10
2.00	49.0	24.0	201 020	10
2.10	49.0	24.0	201 021	10
2.20	53.0	27.0	201 022	10
2.25	53.0	27.0	201 0225	10
2.30	53.0	27.0	201 023	10
2.40	57.0	30.0	201 024	10
2.50	57.0	30.0	201 025	10
2.60	57.0	30.0	201 026	10
2.70	61.0	33.0	201 027	10
2.75	61.0	33.0	201 0275	10
2.80	61.0	33.0	201 028	10
2.90	61.0	33.0	201 029	10
3.00	61.0	33.0	201 030	10
3.10	65.0	36.0	201 031	10
3.20	65.0	36.0	201 032	10
3.25	65.0	36.0	201 0325	10
3.30	65.0	36.0	201 033	10
3.40	70.0	39.0	201 034	10
3.50	70.0	39.0	201 035	10
3.60	70.0	39.0	201 036	10
3.70	70.0	39.0	201 037	10

Ø mm	L1 mm	L2 mm	HSS-R	
3.75	70.0	39.0	201 0375	10
3.80	75.0	43.0	201 038	10
3.90	75.0	43.0	201 039	10
4.00	75.0	43.0	201 040	10
4.10	75.0	43.0	201 041	10
4.20	75.0	43.0	201 042	10
4.25	75.0	43.0	201 0425	10
4.30	80.0	47.0	201 043	10
4.40	80.0	47.0	201 044	10
4.50	80.0	47.0	201 045	10
4.60	80.0	47.0	201 046	10
4.70	80.0	47.0	201 047	10
4.75	80.0	47.0	201 0475	10
4.80	86.0	52.0	201 048	10
4.90	86.0	52.0	201 049	10
5.00	86.0	52.0	201 050	10
5.10	86.0	52.0	201 051	10
5.20	86.0	52.0	201 052	10
5.25	86.0	52.0	201 0525	10
5.30	86.0	52.0	201 053	10
5.40	93.0	57.0	201 054	10
5.50	93.0	57.0	201 055	10
5.60	93.0	57.0	201 056	10
5.70	93.0	57.0	201 057	10
5.75	93.0	57.0	201 0575	10
5.80	93.0	57.0	201 058	10
5.90	93.0	57.0	201 059	10
6.00	93.0	57.0	201 060	10
6.10	101.0	63.0	201 061	10
6.20	101.0	63.0	201 062	10
6.25	101.0	63.0	201 0625	10
6.30	101.0	63.0	201 063	10
6.40	101.0	63.0	201 064	10
6.50	101.0	63.0	201 065	10
6.60	101.0	63.0	201 066	10
6.70	101.0	63.0	201 067	10
6.75	101.0	63.0	201 0675	10
6.80	109.0	69.0	201 068	10
6.90	109.0	69.0	201 069	10
7.00	109.0	69.0	201 070	10

∅ mm	L1 mm	L2 mm	HSS-R	
7.10	109.0	69.0	201 071	10
7.20	109.0	69.0	201 072	10
7.25	109.0	69.0	201 0725	10
7.30	109.0	69.0	201 073	10
7.40	109.0	69.0	201 074	10
7.50	109.0	69.0	201 075	10
7.60	117.0	75.0	201 076	10
7.70	117.0	75.0	201 077	10
7.75	117.0	75.0	201 0775	10
7.80	117.0	75.0	201 078	10
7.90	117.0	75.0	201 079	10
8.00	117.0	75.0	201 080	10
8.10	117.0	75.0	201 081	10
8.20	117.0	75.0	201 082	10
8.25	117.0	75.0	201 0825	10
8.30	117.0	75.0	201 083	10
8.40	117.0	75.0	201 084	10
8.50	117.0	75.0	201 085	10
8.60	125.0	81.0	201 086	10
8.70	125.0	81.0	201 087	10
8.75	125.0	81.0	201 0875	10
8.80	125.0	81.0	201 088	10
8.90	125.0	81.0	201 089	10
9.00	125.0	81.0	201 090	10
9.10	125.0	81.0	201 091	10
9.20	125.0	81.0	201 092	10
9.25	125.0	81.0	201 0925	10
9.30	125.0	81.0	201 093	10
9.40	125.0	81.0	201 094	10
9.50	125.0	81.0	201 095	10
9.60	133.0	87.0	201 096	10
9.70	133.0	87.0	201 097	10
9.75	133.0	87.0	201 0975	10
9.80	133.0	87.0	201 098	10
9.90	133.0	87.0	201 099	10
10.00	133.0	87.0	201 100	10
10.10	133.0	87.0	201 101	10
10.20	133.0	87.0	201 102	10
10.30	133.0	87.0	201 103	10
10.40	133.0	87.0	201 104	10

∅ mm	L1 mm	L2 mm	HSS-R	
10.50	133.0	87.0	201 105	5
10.60	133.0	87.0	201 106	5
10.70	142.0	94.0	201 107	5
10.80	142.0	94.0	201 108	5
10.90	142.0	94.0	201 109	5
11.00	142.0	94.0	201 110	5
11.10	142.0	94.0	201 111	5
11.20	142.0	94.0	201 112	5
11.30	142.0	94.0	201 113	5
11.40	142.0	94.0	201 114	5
11.50	142.0	94.0	201 115	5
11.60	142.0	94.0	201 116	5
11.70	142.0	94.0	201 117	5
11.80	142.0	94.0	201 118	5
11.90	151.0	101.0	201 119	5
12.00	151.0	101.0	201 120	5
12.10	151.0	101.0	201 121	5
12.20	151.0	101.0	201 122	5
12.30	151.0	101.0	201 123	5
12.40	151.0	101.0	201 124	5
12.50	151.0	101.0	201 125	5
12.60	151.0	101.0	201 126	5
12.70	151.0	101.0	201 127	5
12.80	151.0	101.0	201 128	5
12.90	151.0	101.0	201 129	5
13.00	151.0	101.0	201 130	5
13.50	160.0	108.0	201 135	5
14.00	160.0	108.0	201 140	5
14.50	169.0	114.0	201 145	5
15.00	169.0	114.0	201 150	5
15.50	178.0	120.0	201 155	5
16.00	178.0	120.0	201 160	5
16.50	184.0	125.0	201 165	1
17.00	184.0	125.0	201 170	1
17.50	191.0	130.0	201 175	1
18.00	191.0	130.0	201 180	1
18.50	198.0	135.0	201 185	1
19.00	198.0	135.0	201 190	1
19.50	205.0	140.0	201 195	1
20.00	205.0	140.0	201 200	1



		HSS-R
19 tfg./pcs.	Twist drill DIN 338 type N. HSS-R Ø 1.0 mm to 10.0 mm x 0.5 mm increasing	205 212 RO
24 tfg./pcs.	Twist drill DIN 338 type N. HSS-R Ø 1.0 mm to 10.5 mm x 0.5 mm increasing + 3.3 / 4.2 / 6.8 / 10.2 mm	205 216 RO
25 tfg./pcs.	Twist drill DIN 338 type N. HSS-R Ø 1.0 mm to 13.0 mm x 0.5 mm increasing	205 213 RO
41 tfg./pcs.	Twist drill DIN 338 type N. HSS-R Ø 6.0 mm to 10.0 mm x 0.1 mm increasing	205 218 RO
50 tfg./pcs.	Twist drill DIN 338 type N. HSS-R Ø 1.0 mm to 5.9 mm x 0.1 mm increasing	205 217 RO



		HSS-R
91 tfg./pcs.	Twist drill set in workbench stand Ø 1.0 mm to 10.0 mm x 0.1 mm increasing	205 223
570 tfg./pcs.	Drill bit cabinet, equipped 50 pieces each Ø 1.0 - 2.5 mm x 0.5 mm increasing 30 pieces each Ø 3.0 - 5.5 mm x 0.5 mm increasing 20 pieces each Ø 6.0 - 7.5 mm x 0.5 mm increasing 10 pieces each Ø 8.0 - 13.0 mm x 0.5 mm increasing	205 208
	Drill cabinet empty Dimensions: H1: 23.0 cm. L1: 37.0 cm. D1: 9.5 cm. T2: 20.0 cm Ø 1.0 mm to 13.0 mm x 0.5 mm increasing	205 208 L
	Drill cabinet empty Dimensions: H1: 46.5 cm. L1: 39.0 cm. D1: 9.5 cm. T2: 20.0 cm Ø 1.0 mm to 10.0 mm x 0.1 mm increasing Ø 10.5 mm to 13.0 mm x 0.5 mm increasing	205 2081 L





Twist drill DIN 338 type N with reduced shank

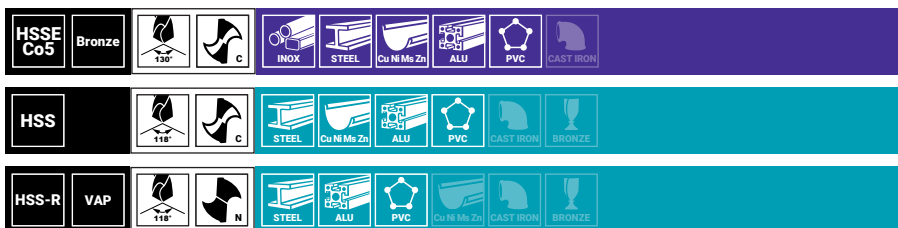

Ideal for drilling larger drill diameters.
Suitable for all standard drills with a chuck up to 13.0 mm.



Ø1 mm	L1 mm	Ø2 mm	L2 mm	HSSE-Co 5		HSS		HSS-R	
10.50	133.0	10.0	30.0	200 5 105	1	200 4 105	1	200 105	1
11.00	142.0	10.0	30.0	200 5 110	1	200 4 110	1	200 110	1
11.50	142.0	10.0	30.0	200 5 115	1	200 4 115	1	200 115	1
12.00	151.0	10.0	30.0	200 5 120	1	200 4 120	1	200 120	1
12.50	151.0	10.0	30.0	200 5 125	1	200 4 125	1	200 125	1
13.00	151.0	10.0	30.0	200 5 130	1	200 4 130	1	200 130	1
13.50	160.0	10.0	30.0	200 5 135	1	200 4 135	1	200 135	1
14.00	160.0	10.0	30.0	200 5 140	1	200 4 140	1	200 140	1
14.50	169.0	10.0	30.0	200 5 145	1	200 4 145	1	200 145	1
15.00	169.0	10.0	30.0	200 5 150	1	200 4 150	1	200 150	1
15.50	178.0	10.0	30.0	200 5 155	1	200 4 155	1	200 155	1
16.00	178.0	10.0	30.0	200 5 160	1	200 4 160	1	200 160	1
16.50	184.0	13.0	35.0	200 5 165	1	200 4 165	1	200 165	1
17.00	184.0	13.0	35.0	200 5 170	1	200 4 170	1	200 170	1
17.50	191.0	13.0	35.0	200 5 175	1	200 4 175	1	200 175	1
18.00	191.0	13.0	35.0	200 5 180	1	200 4 180	1	200 180	1
18.50	198.0	13.0	35.0	200 5 185	1	200 4 185	1	200 185	1
19.00	198.0	13.0	35.0	200 5 190	1	200 4 190	1	200 190	1
19.50	205.0	13.0	35.0	200 5 195	1	200 4 195	1	200 195	1
20.00	205.0	13.0	35.0	200 5 200	1	200 4 200	1	200 200	1
22.00	205.0	13.0	35.0					200 220	1
24.00	205.0	13.0	35.0					200 240	1
25.00	205.0	13.0	35.0					200 250	1

		HSS
10 10 pc./pcs.	Twist drill set DIN 338 type N, HSS with reduced shank Ø 14.0 15.0 15.5 16.0 17.0 17.5 18.0 19.0 19.5 20.0 mm	2004 201





Twist drill DIN 340 type N, HSS-G



High-performance ground standard twist drill made from high speed steel. The fully ground twist drill has a precise concentricity.

Packaging: plastic tube

Ø mm	L1 mm	L2 mm	HSS	
2.50	95.0	62.0	203 025	10
3.00	100.0	66.0	203 030	10
3.30	106.0	69.0	203 033	10
3.50	112.0	73.0	203 035	10
4.00	119.0	78.0	203 040	10
4.20	119.0	78.0	203 042	10
4.50	126.0	82.0	203 045	10
5.00	132.0	87.0	203 050	10
5.50	139.0	91.0	203 055	10
6.00	139.0	91.0	203 060	10
6.50	148.0	97.0	203 065	10
6.80	156.0	102.0	203 068	10
7.00	156.0	102.0	203 070	10
7.50	156.0	102.0	203 075	10
7.80	165.0	109.0	203 078	10
8.00	165.0	109.0	203 080	10
8.50	165.0	109.0	203 085	10
9.00	175.0	115.0	203 090	10
9.50	175.0	115.0	203 095	10
10.00	184.0	121.0	203 100	10
10.50	184.0	121.0	203 105	5
11.00	195.0	128.0	203 110	5
11.50	195.0	128.0	203 115	5
12.00	205.0	134.0	203 120	5
12.50	205.0	134.0	203 125	5
13.00	205.0	134.0	203 130	5

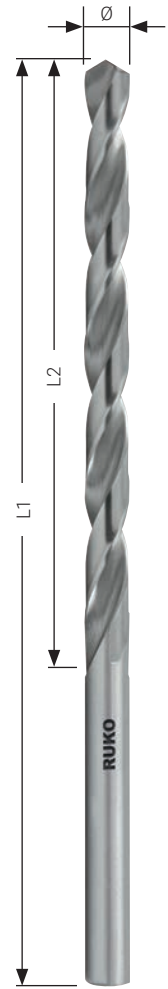

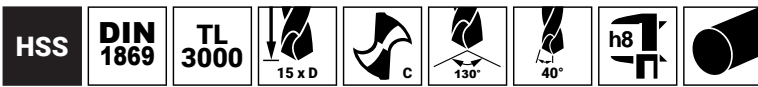

Twist drill DIN 1869 TL 3000, HSS – extra long



Stable special drill. Ideally suitable for deep holes under difficult conditions, e.g. bad chipping materials. Suitable for all usual drilling work in all normal materials.

High rotational precision. For drilling deep holes please use small feed and remove chips frequently.

Packaging: plastic tube

Ø mm	L1 mm	L2 mm	HSS	
2.00	125.0	85.0	254 020	1
2.50	140.0	95.0	254 025	1
3.00	150.0	100.0	254 030	1
3.20	155.0	105.0	254 032	1
3.30	155.0	105.0	254 033	1
3.50	165.0	115.0	254 035	1
4.00	175.0	120.0	254 040	1
4.20	175.0	120.0	254 042	1
4.50	185.0	125.0	254 045	1
5.00	195.0	135.0	254 050	1
5.50	205.0	140.0	254 055	1
6.00	205.0	140.0	254 060	1
6.50	215.0	150.0	254 065	1
7.00	225.0	155.0	254 070	1
7.50	225.0	155.0	254 075	1
8.00	240.0	165.0	254 080	1
8.50	240.0	165.0	254 085	1
9.00	250.0	175.0	254 090	1
9.50	250.0	175.0	254 095	1
10.00	265.0	185.0	254 100	1
10.50	265.0	185.0	254 105	1
11.00	280.0	195.0	254 110	1
11.50	280.0	195.0	254 115	1
12.00	295.0	205.0	254 120	1
12.50	295.0	205.0	254 125	1
13.00	295.0	205.0	254 130	1

Ø mm	L1 mm	L2 mm	HSS	
3.00	190.0	130.0	255 030	1
3.20	200.0	135.0	255 032	1
3.30	200.0	135.0	255 033	1
3.50	210.0	145.0	255 035	1
4.00	220.0	150.0	255 040	1
4.20	220.0	150.0	255 042	1
4.50	235.0	160.0	255 045	1
5.00	245.0	170.0	255 050	1
5.50	260.0	180.0	255 055	1
6.00	260.0	180.0	255 060	1
6.50	275.0	190.0	255 065	1
7.00	290.0	200.0	255 070	1
7.50	290.0	200.0	255 075	1
8.00	305.0	210.0	255 080	1
8.50	305.0	210.0	255 085	1
9.00	320.0	220.0	255 090	1
9.50	320.0	220.0	255 095	1
10.00	340.0	235.0	255 100	1
10.50	340.0	235.0	255 105	1
11.00	365.0	250.0	255 110	1
11.50	365.0	250.0	255 115	1
12.00	375.0	260.0	255 120	1
12.50	375.0	260.0	255 125	1
13.00	375.0	260.0	255 130	1

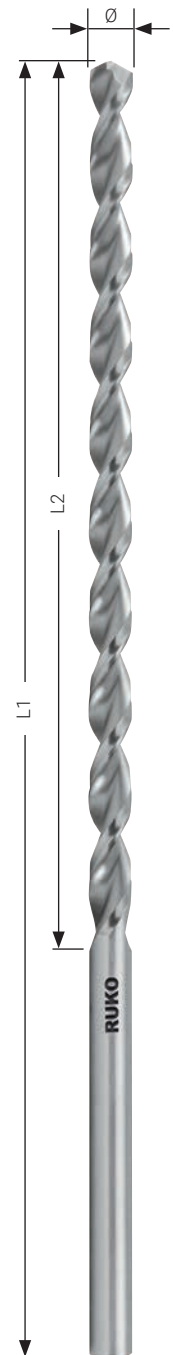



Twist drill DIN 345 type N, HSS + HSSE-Co 5

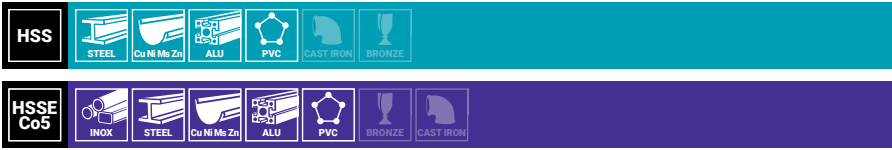

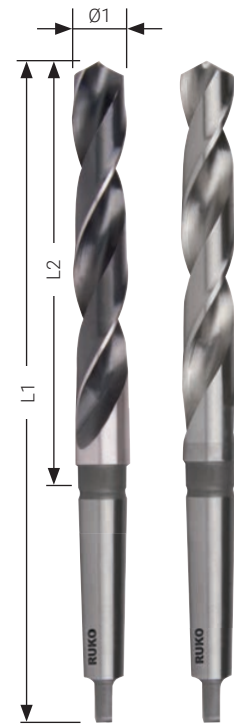

Highly efficient standard drill with morse taper.
For drilling steel, cast steel and cast iron – alloyed and unalloyed. Highly secure against fracture.



Packaging: plastic tube

Ø mm	L1 mm	L2 mm	Morse cone	HSSE-Co 5		HSS	
10.00	168.0	87.0	1	204 100 E	1	204 100	1
10.50	168.0	87.0	1	204 105 E	1	204 105	1
11.00	175.0	94.0	1	204 110 E	1	204 110	1
11.50	175.0	94.0	1	204 115 E	1	204 115	1
12.00	182.0	101.0	1	204 120 E	1	204 120	1
12.50	182.0	101.0	1	204 125 E	1	204 125	1
13.00	182.0	101.0	1	204 130 E	1	204 130	1
13.50	189.0	108.0	1	204 135 E	1	204 135	1
14.00	189.0	108.0	1	204 140 E	1	204 140	1
14.50	212.0	114.0	2	204 145 E	1	204 145	1
15.00	212.0	114.0	2	204 150 E	1	204 150	1
15.50	218.0	120.0	2	204 155 E	1	204 155	1
16.00	218.0	120.0	2	204 160 E	1	204 160	1
16.50	223.0	125.0	2	204 165 E	1	204 165	1
17.00	223.0	125.0	2	204 170 E	1	204 170	1
17.50	228.0	130.0	2	204 175 E	1	204 175	1
18.00	228.0	130.0	2	204 180 E	1	204 180	1
18.50	233.0	135.0	2	204 185 E	1	204 185	1
19.00	233.0	135.0	2	204 190 E	1	204 190	1
19.50	238.0	140.0	2	204 195 E	1	204 195	1
20.00	238.0	140.0	2	204 200 E	1	204 200	1
20.50	243.0	145.0	2	204 205 E	1	204 205	1
21.00	243.0	145.0	2	204 210 E	1	204 210	1
21.50	248.0	150.0	2	204 215 E	1	204 215	1
22.00	248.0	150.0	2	204 220 E	1	204 220	1
22.50	253.0	155.0	2	204 225 E	1	204 225	1
23.00	253.0	155.0	2	204 230 E	1	204 230	1
23.50	276.0	155.0	3	204 235 E	1	204 235	1
24.00	281.0	160.0	3	204 240 E	1	204 240	1
24.50	281.0	160.0	3	204 245 E	1	204 245	1
25.00	281.0	160.0	3	204 250 E	1	204 250	1
25.50	286.0	165.0	3	204 255 E	1	204 255	1
26.00	286.0	165.0	3	204 260 E	1	204 260	1
26.50	286.0	165.0	3	204 265 E	1	204 265	1
27.00	291.0	170.0	3	204 270 E	1	204 270	1
27.50	291.0	170.0	3	204 275 E	1	204 275	1
28.00	291.0	170.0	3	204 280 E	1	204 280	1
28.50	296.0	175.0	3	204 285 E	1	204 285	1
29.00	296.0	175.0	3	204 290 E	1	204 290	1
29.50	296.0	175.0	3	204 295 E	1	204 295	1
30.00	296.0	175.0	3	204 300 E	1	204 300	1

∅ mm	L1 mm	L2 mm	Morse cone	HSSE-Co 5		HSS	
30.50	301.0	180.0	3	-		204 305	1
31.00	301.0	180.0	3	-		204 310	1
31.50	301.0	180.0	3	-		204 315	1
32.00	334.0	185.0	4	-		204 320	1
32.50	334.0	185.0	4	-		204 325	1
33.00	334.0	185.0	4	-		204 330	1
33.50	334.0	185.0	4	-		204 335	1
34.00	339.0	190.0	4	-		204 340	1
34.50	339.0	190.0	4	-		204 345	1
35.00	339.0	190.0	4	-		204 350	1
35.50	339.0	190.0	4	-		204 355	1
36.00	344.0	195.0	4	-		204 360	1
36.50	344.0	195.0	4	-		204 365	1
37.00	344.0	195.0	4	-		204 370	1
37.50	344.0	195.0	4	-		204 375	1
38.00	349.0	200.0	4	-		204 380	1
38.50	349.0	200.0	4	-		204 385	1
39.00	349.0	200.0	4	-		204 390	1
39.50	349.0	200.0	4	-		204 395	1
40.00	349.0	200.0	4	-		204 400	1
40.50	354.0	205.0	4	-		204 405	1
41.00	354.0	205.0	4	-		204 410	1
41.50	354.0	205.0	4	-		204 415	1
42.00	354.0	205.0	4	-		204 420	1
42.50	354.0	205.0	4	-		204 425	1
43.00	359.0	210.0	4	-		204 430	1
43.50	359.0	210.0	4	-		204 435	1
44.00	359.0	210.0	4	-		204 440	1
44.50	359.0	210.0	4	-		204 445	1
45.00	359.0	210.0	4	-		204 450	1
45.50	364.0	215.0	4	-		204 455	1
46.00	364.0	215.0	4	-		204 460	1
46.50	364.0	215.0	4	-		204 465	1
47.00	364.0	215.0	4	-		204 470	1
47.50	364.0	215.0	4	-		204 475	1
48.00	369.0	220.0	4	-		204 480	1
48.50	369.0	220.0	4	-		204 485	1
49.00	369.0	220.0	4	-		204 490	1
49.50	369.0	220.0	4	-		204 495	1
50.00	369.0	220.0	4	-		204 500	1
51.00	412.0	225.0	5	-		204 510	1
52.00	412.0	225.0	5	-		204 520	1
53.00	412.0	225.0	5	-		204 530	1
54.00	417.0	230.0	5	-		204 540	1
55.00	417.0	230.0	5	-		204 550	1
56.00	417.0	230.0	5	-		204 560	1
57.00	422.0	235.0	5	-		204 570	1
58.00	422.0	235.0	5	-		204 580	1
59.00	422.0	235.0	5	-		204 590	1
60.00	422.0	235.0	5	-		204 600	1

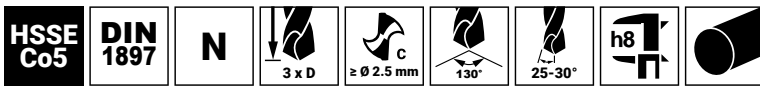

Twist drill DIN 1897 type N, HSSE-Co 5 – short



Short and stable twist drill with distinctive heat resistance. Ideally suited for assembly work with thin-walled materials such as sheet steels, flat steels and profile steel in bodysell construction. Use in hand-held drilling machines, with automatic machines and with turret lathes.

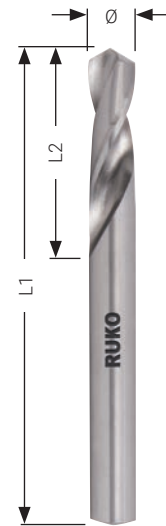

Packaging: plastic tube

Ø mm	L1 mm	L2 mm	HSSE-Co 5	
2.00	38.0	12.0	202 020 E	10
2.50	43.0	14.0	202 025 E	10
3.00	46.0	16.0	202 030 E	10
3.10	49.0	18.0	202 031 E	10
3.20	49.0	18.0	202 032 E	10
3.25	49.0	18.0	202 0325 E	10
3.30	49.0	18.0	202 033 E	10
3.50	52.0	20.0	202 035 E	10
3.60	52.0	20.0	202 036 E	10
4.00	55.0	22.0	202 040 E	10
4.10	55.0	22.0	202 041 E	10
4.20	55.0	22.0	202 042 E	10
4.50	58.0	24.0	202 045 E	10
4.80	62.0	26.0	202 048 E	10
4.90	62.0	26.0	202 049 E	10
5.00	62.0	26.0	202 050 E	10
5.10	62.0	26.0	202 051 E	10
5.20	62.0	26.0	202 052 E	10
5.50	66.0	28.0	202 055 E	10
5.70	66.0	28.0	202 057 E	10
5.80	66.0	28.0	202 058 E	10
5.90	66.0	28.0	202 059 E	10
6.00	66.0	28.0	202 060 E	10
6.30	70.0	31.0	202 063 E	10
6.50	70.0	31.0	202 065 E	10
6.80	74.0	34.0	202 068 E	10
7.00	74.0	34.0	202 070 E	10
7.50	74.0	34.0	202 075 E	10
8.00	79.0	37.0	202 080 E	10
8.50	79.0	37.0	202 085 E	10
9.00	84.0	40.0	202 090 E	10
9.50	84.0	40.0	202 095 E	10
10.00	89.0	43.0	202 100 E	10
10.50	89.0	43.0	202 105 E	5
11.00	95.0	47.0	202 110 E	5
11.50	95.0	47.0	202 115 E	5
12.00	102.0	51.0	202 120 E	5
12.50	102.0	51.0	202 125 E	5
13.00	102.0	51.0	202 130 E	5

Special sizes are also available on request.



Twist drill DIN 1897 type N, HSS – short

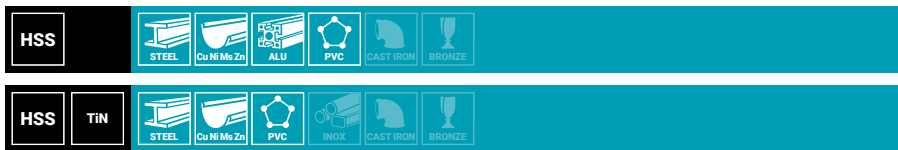

Short and stable twist drill with distinctive heat resistance. Ideally suited for assembly work with thin-walled materials such as sheet steels, flat steels and profile steel in bodyshell construction. Use in hand-held drilling machines, with automatic machines and with turret lathes.

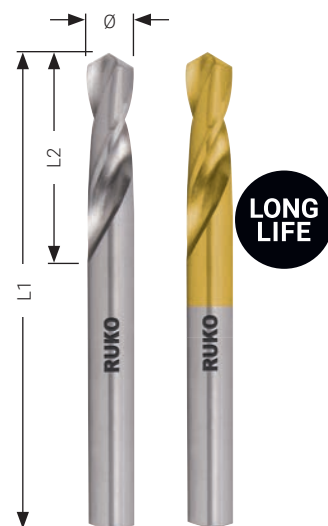

Packaging: plastic tube

ø mm	L1 mm	L2 mm	HSS		HSS TIN	
2.00	38.0	12.0	202 020	10	202 020 T	10
2.50	43.0	14.0	202 025	10	202 025 T	10
3.00	46.0	16.0	202 030	10	202 030 T	10
3.30	49.0	18.0	202 033	10	202 033 T	10
3.50	52.0	20.0	202 035	10	202 035 T	10
4.00	55.0	22.0	202 040	10	202 040 T	10
4.20	55.0	22.0	202 042	10	202 042 T	10
4.50	58.0	24.0	202 045	10	202 045 T	10
5.00	62.0	26.0	202 050	10	202 050 T	10
5.50	66.0	28.0	202 055	10	202 055 T	10
5.00	86.0	52.0	202 050	10	202 050 F	10
5.50	93.0	57.0	202 055	10	202 055 F	10
6.00	66.0	28.0	202 060	10	202 060 T	10
6.50	70.0	31.0	202 065	10	202 065 T	10
6.80	74.0	34.0	202 068	10	202 068 T	10
7.00	74.0	34.0	202 070	10	202 070 T	10
7.50	74.0	34.0	202 075	10	202 075 T	10
8.00	79.0	37.0	202 080	10	202 080 T	10
8.50	79.0	37.0	202 085	10	202 085 T	10
9.00	84.0	40.0	202 090	10	202 090 T	10
9.50	84.0	40.0	202 095	10	202 095 T	10
10.00	89.0	43.0	202 100	10	202 100 T	10
10.20	89.0	43.0	202 102	10	202 102 T	10
10.50	89.0	43.0	202 105	5	202 105 T	5
11.00	95.0	47.0	202 110	5	202 110 T	5
11.50	95.0	47.0	202 115	5	202 115 T	5
12.00	102.0	51.0	202 120	5	202 120 T	5
12.50	102.0	51.0	202 125	5	202 125 T	5
13.00	102.0	51.0	202 130	5	202 130 T	5



Double end drill type KV, HSS



Extra short and stable standard drill. Shorter than DIN 1897. Ideally suitable for assembly work in thin-walled materials such as sheet steels, flat steels and profile steels. High security against fracture. For use in hand-held drilling machines. Usable at both ends.

Advantages DIN 1412 C: good centering, little pressure required. Chip distribution improves chip removal.



Packaging: plastic tube

Ø1 mm	L1 mm	L2 mm	HSS	
2.50	43.0	10.0	252 025	10
2.80	46.0	11.0	252 028	10
3.00	46.0	11.0	252 030	10
3.10	49.0	11.0	252 031	10
3.20	49.0	11.0	252 032	10
3.25	49.0	11.0	252 0325	10
3.30	49.0	11.0	252 033	10
3.40	52.0	14.0	252 034	10
3.50	52.0	14.0	252 035	10
4.00	55.0	14.0	252 040	10
4.10	55.0	14.0	252 041	10

Ø1 mm	L1 mm	L2 mm	HSS	
4.20	55.0	14.0	252 042	10
4.30	58.0	17.0	252 043	10
4.50	58.0	17.0	252 045	10
4.80	62.0	17.0	252 048	10
4.90	62.0	17.0	252 049	10
5.00	62.0	17.0	252 050	10
5.10	62.0	17.0	252 051	10
5.20	62.0	17.0	252 052	10
5.50	66.0	20.0	252 055	10
6.00	66.0	20.0	252 060	10
6.50	70.0	20.0	252 065	10



Centre drill DIN 333, HSS



Centre drills for making centre holes according to shape A.



Packaging: plastic tube

Ø1 mm	L1 mm	L2 mm	HSS	
0.80	20.0	3.15	217 008	1
1.00	31.5	3.15	217 010	1
1.60	35.5	4.00	217 016	1
2.00	40.0	5.00	217 020	1
2.50	45.0	6.30	217 025	1
3.15	50.0	8.00	217 315	1
4.00	56.0	10.00	217 040	1
5.00	63.0	12.50	217 050	1
6.30	71.0	16.00	217 063	1

Use of the drills and cutting conditions

Material	Recommended application		Cooling	Cutting speed v [m/min]	Drill diameter d [mm]				
	Main suggestion	Other suggestion			2	4	6	9	12
					Feed rate f [mm/rotation]				
Free cutting steel 350-500 N/mm2	214 ...	258 ... / 202 ...	E	30-40	0,05	0,1	0,125	0,16	0,2
Free cutting steel 500-900 N/mm2	214 ...	228 ... / 202 ...	E	25-30	0,04	0,08	0,1	0,125	0,16
Structural steel up to 500 N/mm2	214 ...	258 ... / 202 ...	E	30-40	0,04	0,08	0,1	0,125	0,16
Structural steel 500-900 N/mm2	214 ...	228 ... / 202 ...	E	20-25	0,032	0,063	0,08	0,1	0,125
Plain carbon case hardening steel up to 600 N/mm2	214 ...	258 ... / 202 ...	E	25-35	0,05	0,1	0,125	0,16	0,2
Alloyed case hardening steel 500-900 N/mm2	214 ...	228 ... / 202 ...	E	20-25	0,4	0,08	0,1	0,125	0,16
Alloyed case hardening steel 900-1000 N/mm2	281 ... E	202 ... E	E, O	10-15	0,025	0,05	0,063	0,08	0,1
Nitriding steel 700-900 N/mm2	281 ... E	228 ... / 202 ... E	E	15-20	0,032	0,063	0,08	0,1	0,125
Heat treated nitriding steel 800-1250 N/mm2	281 ... E	228 ...	E, O	8-12	0,025	0,05	0,063	0,08	0,1
Mild steel for heat treatment 500-750 N/mm2	214 ...	228 ... / 202 ...	E	25-35	0,04	0,08	0,1	0,125	0,16
Plain carbon steel for heat treatment 700-1000 N/mm2	281 ... E	228 ...	E	15-20	0,04	0,08	0,1	0,125	0,16
Alloyed steel heat treatment 900-1250 N/mm2	281 ... E	228 ...	E, O	10-15	0,032	0,063	0,08	0,1	0,125
Maganese steel with content over 10 % Mn	281 ... E	202 ... E	E, O	3-6	0,2	0,04	0,063	0,08	0,1
Plain carbon tool steel 700-900 N/mm2	281 ... E	228 ... / 202 ... E	E	14-18	0,032	0,063	0,08	0,1	0,12
Alloyed tool steel 850-1250 N/mm2	281 ... E	228 ...	E, O	8-12	0,025	0,05	0,063	0,08	0,1
Heat resistant steel 450-600 N/mm2	281 ... E	281 ... EF	O	15-20	0,032	0,063	0,08	0,1	0,125
Stainless steel	215 ...	281 ... E	E, O	6-10	0,02	0,032	0,05	0,08	0,1
Alloys hastelloy, inconel, nimonic	281 ... E	281 ... EF	O	3-6	0,02	0,04	0,063	0,08	0,125
Grey cast iron HB 180-240	214 ...	228 ...	E, DL	30-40	0,05	0,1	0,125	0,16	0,2
Grey cast iron HB 240-300	214 ...	228 ...	E, DL	20-30	0,05	0,1	0,125	0,16	0,2
Malleable cast iron HB 180-240	214 ...	228 ...	DL	20-30	0,05	0,1	0,125	0,16	0,2
Aluminium	258 ... F	258 ...	E	50-80	0,05	0,1	0,125	0,16	0,2
Aluminium alloys with content up to 10 % Si and 180 N/mm2	258 ... F	258 ...	E	40-65	0,063	0,1255	0,16	0,2	0,25
Aluminium alloys with content up to 10 % Si and 150-250 N/mm2	214 ...	202 ...	E	30-50	0,063	0,1255	0,16	0,2	0,25
Copper 200-400 N/mm2	258 ... F	228 ...	E, O	30-40	0,05	0,1	0,125	0,16	0,2
Fragile brass with short chip 350-550 N/mm2	281 ... E	281 ... EF	E, O	60-80	0,063	0,1255	0,16	0,2	0,25
Tough brass with long chip 250-550 N/mm2	258 ... F	258 ... F	E, O	30-50	0,063	0,1	0,125	0,16	0,2
Bronze 200-500 N/mm2	258 ... F	258 ... F	E, O	20-40	0,05	0,08	0,125	0,16	0,2
Bronze 500-800 N/mm2	214 ...	258 ...	E, O	15-30	0,05	0,08	0,125	0,16	0,2
Magnesium alloys-electron	281 ... E	281 ... EF	-	60-100	0,08	0,125	0,016	0,02	0,25
Zinc, zinc alloys	214 ...	258 ...	E	35-45	0,05	0,1	0,125	0,16	0,2
Titanium alloys up to 700 N/mm2	281 ... E	281 ... EF	O	3-6	0,03	0,05	0,063	0,08	0,1
Titanium alloys 700-1000 N/mm2	281 ... E	281 ... EF	O	3-6	0,02	0,04	0,05	0,063	0,08
Silver	214 ...	258 ...	E	30-40	0,05	0,08	0,1	0,125	0,16
Duroplastics	281 ... E	281 ... EF	DL	10-20	0,04	0,08	0,1	0,125	0,16
Thermoplastics	258 ... F	258 ... F	W, DL	20-40	0,05	0,1	0,125	0,16	0,2
Laminated materials (paper, wood) across layer	258 ... F	258 ... F	DL	15-25	0,05	0,08	0,125	0,16	0,2

E = emulsion / O = cutting oil / CA = compressed air / W = water

Speed table for twist drills



Material	Cutting speed Vc m/min	Coolant	Material	Cutting speed Vc m/min	Coolant
High carbon struc. steel < 700 N/mm ²	30 - 35	cutting spray	CuZn alloy tough	35 - 60	compressed air
High carbon struc. steel > 700 N/mm ²	20 - 25	cutting spray	Al alloy 11% Si	30 - 50	cutting spray
Alloyed steel < 1000 N/mm ²	20 - 25	cutting spray	Thermoplastics	20 - 40	water
Cast iron < 250 N/mm ²	15 - 25	compressed air	Duroplastics with inorganic filling	15 - 25	compressed air
Cast iron > 250 N/mm ²	10 - 20	compressed air	Duroplastics with organic filling	15 - 35	compressed air
CuZn alloy brittle	60 - 100	compressed air			

Drills Ø mm	Cutting speed Vc = m/min															
	4	6	8	10	12	15	18	20	25	30	35	40	50	60	80	100
	r.p.m.															
1.0	1274	1911	2548	3185	3822	4777	5732	6369	7962	9554	11146	12739	15924	19108	25478	31847
1.5	849	1274	1699	2123	2548	3185	3822	4246	5308	6369	7431	8493	10616	12739	16985	21231
2.0	637	955	1274	1592	1911	2389	2866	3185	3981	4777	5573	6369	7962	9554	12739	15924
2.5	510	764	1019	1274	1529	1911	2293	2548	3185	3822	4459	5096	6369	7643	10191	12739
3.0	425	637	849	1062	1274	1592	1911	2123	2654	3185	3715	4246	5308	6369	8493	10616
3.5	364	546	728	910	1092	1365	1638	1820	2275	2730	3185	3640	4550	5460	7279	9099
4.0	318	478	637	796	955	1194	1433	1592	1990	2389	2787	3185	3981	4777	6369	7962
4.5	283	425	566	708	849	1062	1274	1415	1769	2123	2477	2831	3539	4246	5662	7077
5.0	255	382	510	637	764	955	1146	1274	1592	1911	2229	2548	3185	3822	5096	6369
5.5	232	347	463	579	695	869	1042	1158	1448	1737	2027	2316	2895	3474	4632	5790
6.0	212	318	425	531	637	796	955	1062	1327	1592	1858	2123	2654	3185	4246	5308
6.5	196	294	392	490	588	735	882	980	1225	1470	1715	1960	2450	2940	3920	4900
7.0	182	273	364	455	546	682	819	910	1137	1365	1592	1820	2275	2730	3640	4550
7.5	170	255	340	425	510	637	764	849	1062	1274	1486	1699	2123	2548	3397	4246
8.0	159	239	318	398	478	597	717	796	995	1194	1393	1592	1990	2389	3185	3981
8.5	150	225	300	375	450	562	674	749	937	1124	1311	1499	1873	2248	2997	3747
9.0	142	212	283	354	425	531	637	708	885	1062	1238	1415	1769	2123	2831	3539
9.5	134	201	268	335	402	503	603	670	838	1006	1173	1341	1676	2011	2682	3352
10.0	127	191	255	318	382	478	573	637	796	955	1115	1274	1592	1911	2548	3185
11.0	116	174	232	290	347	434	521	579	724	869	1013	1158	1448	1737	2316	2895
12.0	106	159	212	265	318	398	478	531	663	796	929	1062	1327	1592	2123	2654
13.0	98	147	196	245	294	367	441	490	612	735	857	980	1225	1470	1960	2450
14.0	91	136	182	227	273	341	409	455	569	682	796	910	1137	1365	1820	2275
15.0	85	127	170	212	255	318	382	425	531	637	743	849	1062	1274	1699	2123
16.0	80	119	159	199	239	299	358	398	498	597	697	796	995	1194	1592	1990
17.0	75	112	150	187	225	281	337	375	468	562	656	749	937	1124	1499	1873
18.0	71	106	142	177	212	265	318	354	442	531	619	708	885	1062	1415	1769
19.0	67	101	134	168	201	251	302	335	419	503	587	670	838	1006	1341	1676
20.0	64	96	127	159	191	239	287	318	398	478	557	637	796	955	1274	1592
21.0	61	91	121	152	182	227	273	303	379	455	531	607	758	910	1213	1517
22.0	58	87	116	145	174	217	261	290	362	434	507	579	724	869	1158	1448
23.0	55	83	111	138	166	208	249	277	346	415	485	554	692	831	1108	1385
24.0	53	80	106	133	159	199	239	265	332	398	464	531	663	796	1062	1327
25.0	51	76	102	127	153	191	229	255	318	382	446	510	637	764	1019	1274
26.0	49	73	98	122	147	184	220	245	306	367	429	490	612	735	980	1225
27.0	47	71	94	118	142	177	212	236	295	354	413	472	590	708	944	1180
28.0	45	68	91	114	136	171	205	227	284	341	398	455	569	682	910	1137
29.0	44	66	88	110	132	165	198	220	275	329	384	439	549	659	879	1098
30.0	42	64	85	106	127	159	191	212	265	318	372	425	531	637	849	1062
31.0	41	62	82	103	123	154	185	205	257	308	360	411	514	616	822	1027
32.0	40	60	80	100	119	149	179	199	249	299	348	398	498	597	796	995
33.0	39	58	77	97	116	145	174	193	241	290	338	386	483	579	772	965
34.0	37	56	75	94	112	141	169	187	234	281	328	375	468	562	749	937
35.0	36	55	73	91	109	136	164	182	227	273	318	364	455	546	728	910
36.0	35	53	71	88	106	133	159	177	221	265	310	354	442	531	708	885
37.0	34	52	69	86	103	129	155	172	215	258	301	344	430	516	689	861
38.0	34	50	67	84	101	126	151	168	210	251	293	335	419	503	670	838
39.0	33	49	65	82	98	122	147	163	204	245	286	327	408	490	653	817
40.0	32	48	64	80	96	119	143	159	199	239	279	318	398	478	637	796
41.0	31	47	62	78	93	117	140	155	194	233	272	311	388	466	621	777
42.0	30	45	61	76	91	114	136	152	190	227	265	303	379	455	607	758
43.0	30	44	59	74	89	111	133	148	185	222	259	296	370	444	593	741
44.0	29	43	58	72	87	109	130	145	181	217	253	290	362	434	579	724
45.0	28	42	57	71	85	106	127	142	177	212	248	283	354	425	566	708
46.0	28	42	55	69	83	104	125	138	173	208	242	277	346	415	554	692
47.0	27	41	54	68	81	102	122	136	169	203	237	271	339	407	542	678
48.0	27	40	53	66	80	100	119	133	166	199	232	265	332	398	531	663
49.0	26	39	52	65	78	97	117	130	162	195	227	260	325	390	520	650
50.0	25	38	51	64	76	96	115	127	159	191	223	255	318	382	510	637

Speed table for twist drills



Material	Cutting speed Vc m/min	Coolant	Material	Cutting speed Vc m/min	Coolant
High carbon struc. steel < 700 N/mm ²	30 - 35	cutting spray	CuZn alloy tough	35 - 60	compressed air
High carbon struc. steel > 700 N/mm ²	20 - 25	cutting spray	Al alloy 11% Si	30 - 50	cutting spray
Alloyed steel < 1000 N/mm ²	20 - 25	cutting spray	Thermoplastics	20 - 40	water
Cast iron < 250 N/mm ²	15 - 25	compressed air	Duroplastics with inorganic filling	15 - 25	compressed air
Cast iron > 250 N/mm ²	10 - 20	compressed air	Duroplastics with organic filling	15 - 35	compressed air
CuZn alloy brittle	60 - 100	compressed air			

Drills Ø inch	Cutting speed Vc = m/min															
	4	6	8	10	12	15	18	20	25	30	35	40	50	60	80	100
	Speed rpm															
1/16	800	1190	1590	1990	2390	2990	3580	3980	4980	5970	6970	7960	9950	11940	15920	19900
5/64	640	960	1270	1590	1910	2390	2870	3180	3980	4780	5570	6370	7960	9550	12740	15920
3/32	530	800	1060	1330	1590	1990	2390	2650	3320	3980	4640	5310	6630	7960	10620	13270
7/64	450	680	910	1140	1360	1710	2050	2270	2840	3410	3980	4550	5690	6820	9100	11370
1/8	400	600	800	1000	1190	1490	1790	1990	2490	2990	3480	3980	4980	5970	7960	9950
9/64	350	530	710	880	1060	1330	1590	1770	2210	2650	3100	3540	4420	5310	7080	8850
5/32	320	480	640	800	960	1190	1430	1590	1990	2390	2790	3180	3980	4780	6370	7960
11/64	290	430	580	720	870	1090	1300	1450	1810	2170	2530	2900	3620	4340	5790	7240
3/16	270	400	530	660	800	1000	1190	1330	1660	1990	2320	2650	3320	3980	5310	6630
13/64	240	370	490	610	730	920	1100	1220	1530	1840	2140	2450	3060	3670	4900	6120
7/32	230	340	450	570	680	850	1020	1140	1420	1710	1990	2270	2840	3410	4550	5690
15/64	210	320	420	530	640	800	960	1060	1330	1590	1860	2120	2650	3180	4250	5310
1/4	200	300	400	500	600	750	900	1000	1240	1490	1740	1990	2490	2990	3980	4980
17/64	190	290	380	480	570	710	860	950	1190	1430	1660	1900	2380	2850	3800	4750
9/32	180	270	360	450	540	670	810	900	1120	1350	1570	1790	2240	2690	3590	4490
19/64	170	250	340	420	510	640	760	850	1060	1270	1490	1700	2120	2550	3400	4250
5/16	160	240	320	400	480	600	730	810	1010	1210	1410	1610	2020	2420	3230	4030
21/64	150	230	310	380	460	580	690	770	960	1150	1340	1530	1920	2300	3070	3840
11/32	150	220	290	370	440	550	660	730	920	1100	1280	1460	1830	2200	2930	3660
23/64	140	210	280	350	420	520	630	700	870	1050	1220	1400	1750	2100	2800	3500
3/8	130	200	270	340	400	500	600	670	840	1010	1170	1340	1680	2010	2680	3350
25/64	130	190	260	320	390	480	580	640	800	970	1130	1290	1610	1930	2570	3220
13/32	120	190	250	310	370	460	560	620	770	930	1080	1240	1550	1860	2470	3090
27/64	120	180	240	300	360	450	540	600	740	890	1040	1190	1490	1790	2380	2980
7/16	110	170	230	290	340	430	520	570	720	860	1000	1150	1430	1720	2300	2870
29/64	110	170	220	280	330	420	500	550	690	830	970	1110	1380	1660	2220	2770
15/32	110	160	210	270	320	400	480	540	670	800	940	1070	1340	1610	2140	2680
31/64	110	160	210	260	310	390	470	520	650	780	910	1040	1290	1550	2070	2590
1/2	110	150	200	250	300	380	450	500	630	750	880	1000	1250	1500	2010	2510

02



SPECIAL DRILLS

Spot weld miller HSS	62
Spot weld drill HSSE-Co 5 + HSSE-Co 5 TiCN + carbide AlTiN	63
Milling drill HSS + TiN	63
Table of cutting speeds for special drills	64

Spot weld miller HSS

02



For removing spot welds from sheet metal. Exchangeable and double-headed milling crown. Adjustable milling depth with setting screw. No tearing of the sheet metal. No deformation of the sheet metal. Efficient and rapid working.

		L1 mm	Ø mm	HSS
1 tfg./pcs.	Spot weld miller, complete	72.0	-	101 101
5 tfg./pcs.	Milling crown	-	9.6	101 102
1 tfg./pcs.	Centering pin	-	2.5	101 103

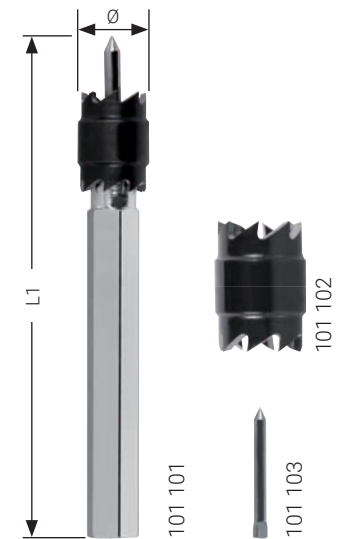

Packaging: plastic

		HSS
13 tfg./pcs.	Spot weld miller set 1 spot weld miller, complete + 10 milling crowns + 2 centering pins	101 104

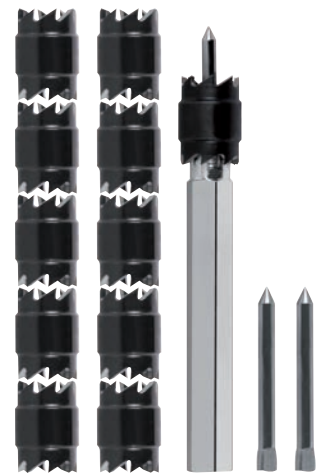

Packaging: plastic

		HSS HSSE-Co 5
9 tfg./pcs.	Spot weld miller-special set 1 spot weld miller, complete + 5 milling + 2 centering pins + 1 fast cut HSSE-Co 5 - Ø 8.0 mm	101 104 M





Spot weld drill HSSE-Co 5 and carbide



Extra stable special drill for hard materials for use in hand drills. Well suited to achieve clean and burr-free milling of spot welds and thin walled work pieces without need to centre mark. Very high precision. Applications include: sheet steel, sheet brass, sheet aluminium, sheet zinc, sheet copper, plastic sheet.

Packaging: plastic

Ø mm	L1 mm	HSSE-Co 5	HSSE-Co 5 TiCN	HM / TC AITiN
6.0	66.0	101 107	101 107 TC	101 107 HM
7.0	74.0	101 111	—	—
8.0	80.0	101 108	101 108 TC	101 108 HM
10.0	88.0	101 114	101 114 TC	—



Milling drill HSS

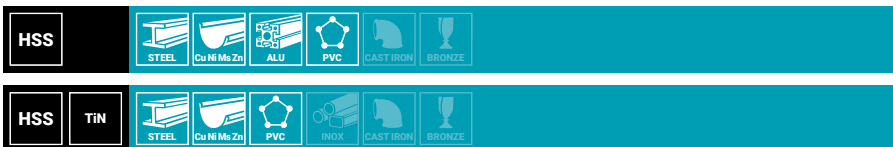

For drilling and milling contours in wood, sheet metal, plastics and other thin-walled materials. Twist drill at tip with milling cutter with chip breakers afterwards.

Packaging: plastic

Ø mm	L1 mm	HSS	HSS TiN
6.0	90.0	101 201	101 201 T
8.0	90.0	101 202	101 202 T

Table of cutting speeds for special drills



Material	Cutting speed Vc m/min	Coolant	Material	Cutting speed Vc m/min	Coolant
High carbon struc. steel < 700 N/mm ²	30 - 35	cutting spray	CuZn alloy tough	35 - 60	compressed air
High carbon struc. steel > 700 N/mm ²	20 - 25	cutting spray	Al alloy 11% Si	30 - 50	cutting spray
Alloyed steel < 1000 N/mm ²	20 - 25	cutting spray	Thermoplastics	20 - 40	water
Cast iron < 250 N/mm ²	15 - 25	compressed air	Duroplastics with inorganic filling	15 - 25	compressed air
Cast iron > 250 N/mm ²	10 - 20	compressed air	Duroplastics with organic filling	15 - 35	compressed air
CuZn alloy brittle	60 - 100	compressed air			

Drills Ø mm	Cutting speed Vc = m/min															
	4	6	8	10	12	15	18	20	25	30	35	40	50	60	80	100
	r.p.m.															
1.0	1274	1911	2548	3185	3822	4777	5732	6369	7962	9554	11146	12739	15924	19108	25478	31847
1.5	849	1274	1699	2123	2548	3185	3822	4246	5308	6369	7431	8493	10616	12739	16985	21231
2.0	637	955	1274	1592	1911	2389	2866	3185	3981	4777	5573	6369	7962	9554	12739	15924
2.5	510	764	1019	1274	1529	1911	2293	2548	3185	3822	4459	5096	6369	7643	10191	12739
3.0	425	637	849	1062	1274	1592	1911	2123	2654	3185	3715	4246	5308	6369	8493	10616
3.5	364	546	728	910	1092	1365	1638	1820	2275	2730	3185	3640	4550	5460	7279	9099
4.0	318	478	637	796	955	1194	1433	1592	1990	2389	2787	3185	3981	4777	6369	7962
4.5	283	425	566	708	849	1062	1274	1415	1769	2123	2477	2831	3539	4246	5662	7077
5.0	255	382	510	637	764	955	1146	1274	1592	1911	2229	2548	3185	3822	5096	6369
5.5	232	347	463	579	695	869	1042	1158	1448	1737	2027	2316	2895	3474	4632	5790
6.0	212	318	425	531	637	796	955	1062	1327	1592	1858	2123	2654	3185	4246	5308
6.5	196	294	392	490	588	735	882	980	1225	1470	1715	1960	2450	2940	3920	4900
7.0	182	273	364	455	546	682	819	910	1137	1365	1592	1820	2275	2730	3640	4550
7.5	170	255	340	425	510	637	764	849	1062	1274	1486	1699	2123	2548	3397	4246
8.0	159	239	318	398	478	597	717	796	995	1194	1393	1592	1990	2389	3185	3981
8.5	150	225	300	375	450	562	674	749	937	1124	1311	1499	1873	2248	2997	3747
9.0	142	212	283	354	425	531	637	708	885	1062	1238	1415	1769	2123	2831	3539
9.5	134	201	268	335	402	503	603	670	838	1006	1173	1341	1676	2011	2682	3352
10.0	127	191	255	318	382	478	573	637	796	955	1115	1274	1592	1911	2548	3185
11.0	116	174	232	290	347	434	521	579	724	869	1013	1158	1448	1737	2316	2895
12.0	106	159	212	265	318	398	478	531	663	796	929	1062	1327	1592	2123	2654
13.0	98	147	196	245	294	367	441	490	612	735	857	980	1225	1470	1960	2450
14.0	91	136	182	227	273	341	409	455	569	682	796	910	1137	1365	1820	2275
15.0	85	127	170	212	255	318	382	425	531	637	743	849	1062	1274	1699	2123
16.0	80	119	159	199	239	299	358	398	498	597	697	796	995	1194	1592	1990
17.0	75	112	150	187	225	281	337	375	468	562	656	749	937	1124	1499	1873
18.0	71	106	142	177	212	265	318	354	442	531	619	708	885	1062	1415	1769
19.0	67	101	134	168	201	251	302	335	419	503	587	670	838	1006	1341	1676
20.0	64	96	127	159	191	239	287	318	398	478	557	637	796	955	1274	1592
21.0	61	91	121	152	182	227	273	303	379	455	531	607	758	910	1213	1517
22.0	58	87	116	145	174	217	261	290	362	434	507	579	724	869	1158	1448
23.0	55	83	111	138	166	208	249	277	346	415	485	554	692	831	1108	1385
24.0	53	80	106	133	159	199	239	265	332	398	464	531	663	796	1062	1327
25.0	51	76	102	127	153	191	229	255	318	382	446	510	637	764	1019	1274
26.0	49	73	98	122	147	184	220	245	306	367	429	490	612	735	980	1225
27.0	47	71	94	118	142	177	212	236	295	354	413	472	590	708	944	1180
28.0	45	68	91	114	136	171	205	227	284	341	398	455	569	682	910	1137
29.0	44	66	88	110	132	165	198	220	275	329	384	439	549	659	879	1098
30.0	42	64	85	106	127	159	191	212	265	318	372	425	531	637	849	1062
31.0	41	62	82	103	123	154	185	205	257	308	360	411	514	616	822	1027
32.0	40	60	80	100	119	149	179	199	249	299	348	398	498	597	796	995
33.0	39	58	77	97	116	145	174	193	241	290	338	386	483	579	772	965
34.0	37	56	75	94	112	141	169	187	234	281	328	375	468	562	749	937
35.0	36	55	73	91	109	136	164	182	227	273	318	364	455	546	728	910
36.0	35	53	71	88	106	133	159	177	221	265	310	354	442	531	708	885
37.0	34	52	69	86	103	129	155	172	215	258	301	344	430	516	689	861
38.0	34	50	67	84	101	126	151	168	210	251	293	335	419	503	670	838
39.0	33	49	65	82	98	122	147	163	204	245	286	327	408	490	653	817
40.0	32	48	64	80	96	119	143	159	199	239	279	318	398	478	637	796
41.0	31	47	62	78	93	117	140	155	194	233	272	311	388	466	621	777
42.0	30	45	61	76	91	114	136	152	190	227	265	303	379	455	607	758
43.0	30	44	59	74	89	111	133	148	185	222	259	296	370	444	593	741
44.0	29	43	58	72	87	109	130	145	181	217	253	290	362	434	579	724
45.0	28	42	57	71	85	106	127	142	177	212	248	283	354	425	566	708
46.0	28	42	55	69	83	104	125	138	173	208	242	277	346	415	554	692
47.0	27	41	54	68	81	102	122	136	169	203	237	271	339	407	542	678
48.0	27	40	53	66	80	100	119	133	166	199	232	265	332	398	531	663
49.0	26	39	52	65	78	97	117	130	162	195	227	260	325	390	520	650
50.0	25	38	51	64	76	96	115	127	159	191	223	255	318	382	510	637

GSR-02

The screen displays a data table with the following structure:

Station	Time	Time	Time	Time	Time
Station 1	00:00	00:00	00:00	00:00	00:00
Station 2	00:00	00:00	00:00	00:00	00:00
Station 3	00:00	00:00	00:00	00:00	00:00
Station 4	00:00	00:00	00:00	00:00	00:00
Station 5	00:00	00:00	00:00	00:00	00:00
Station 6	00:00	00:00	00:00	00:00	00:00
Station 7	00:00	00:00	00:00	00:00	00:00
Station 8	00:00	00:00	00:00	00:00	00:00
Station 9	00:00	00:00	00:00	00:00	00:00
Station 10	00:00	00:00	00:00	00:00	00:00

BECKHOFF



03



TUBE AND SHEET DRILLS

HSS + TiN + HSSE-Co 5 with split point	68
Bit HSS with split point	69
Table of cutting speeds for sheet drills	70

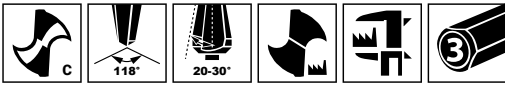

Tube and sheet drill HSS and HSSE-Co 5 with split point



The CBN ground flutes guarantee quiet running and high cutting performance. The cone makes it easier to withdraw the tool from the material.

Packaging: plastic tubes

Size no.	Ø1 - Ø2 mm	L1 mm	Ø3 mm	HSS		HSS TiN		HSSE-Co 5	
1	3.0 - 14.0	58.0	6.0	101 001	1	101 001 T	1	101 001 E	1
2	4.0 - 20.0	71.0	8.0	101 002	1	101 002 T	1	101 002 E	1
3	16.0 - 30.5	76.0	9.0	101 003	1	101 003 T	1	101 003 E	1
4	24.0 - 40.0	89.0	10.0	101 004	1	101 004 T	—	—	—
5	36.0 - 50.0	97.0	12.0	101 005	1	—	—	—	—
6	40.0 - 61.0	103.0	13.0	101 006	1	—	—	—	—
7	5.0 - 25.4	87.0	10.0	101 007	1	—	—	—	—
8	5.0 - 31.0	103.0	9.0	101 008	1	101 008 T	1	101 008 E	1
9	5.0 - 22.5	79.0	8.0	101 022	1	—	—	—	—

		HSS	HSS TiN	HSSE-Co 5
4 <small>tlg./pcs.</small>	Sheet drill set in sizes 1, 2, 3 and 1 tin of cutting paste 20 g	101 020 RO	101 020 TRO	101 020 ERO





Tube and sheet drill bit HSS with split point



The CBN ground flutes guarantee quiet running and high cutting performance. The relief angle on the underside of the tool enables easier removal from the material.

Packaging: plastic tubes

Size no.	Ø1 - Ø2 mm	L1 mm	Ø3 mm	Ø3 inch	HSS	
2	5.0 - 20.0	78.0	6.35 x 27.0	1/4"	101 049 H	1



Product information

1. CBN ground flute

Thanks to the CBN deep-ground flutes, the cutting edges are burr-free and sharp in contrast to the conventional milled flutes. This results in a significantly higher cutting performance and a much longer tool life.

2. Radially adjusted relief produced by CBN grinding

Thanks to the radial CBN relief grinding, the cutting edge is clearly the highest point in the diameter.

3. Flute

The straight or spiral flute offers absolute running smoothness and high cutting performance. In the spiral flute non-breaking chips in particular are transported away cleanly as with a spiral drill.

4. Cone at the end

The cone at the end of these tube and sheet drills makes it easier to withdraw the tool from the material.

5. CBN ground bit with split point DIN 1412 C

The high-performance drill point with special CBN grinding enables centring and spot drilling even in thin-walled materials.

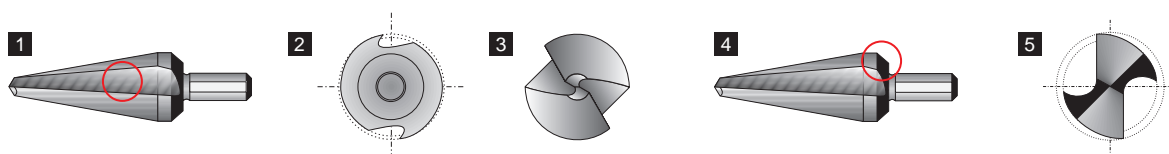
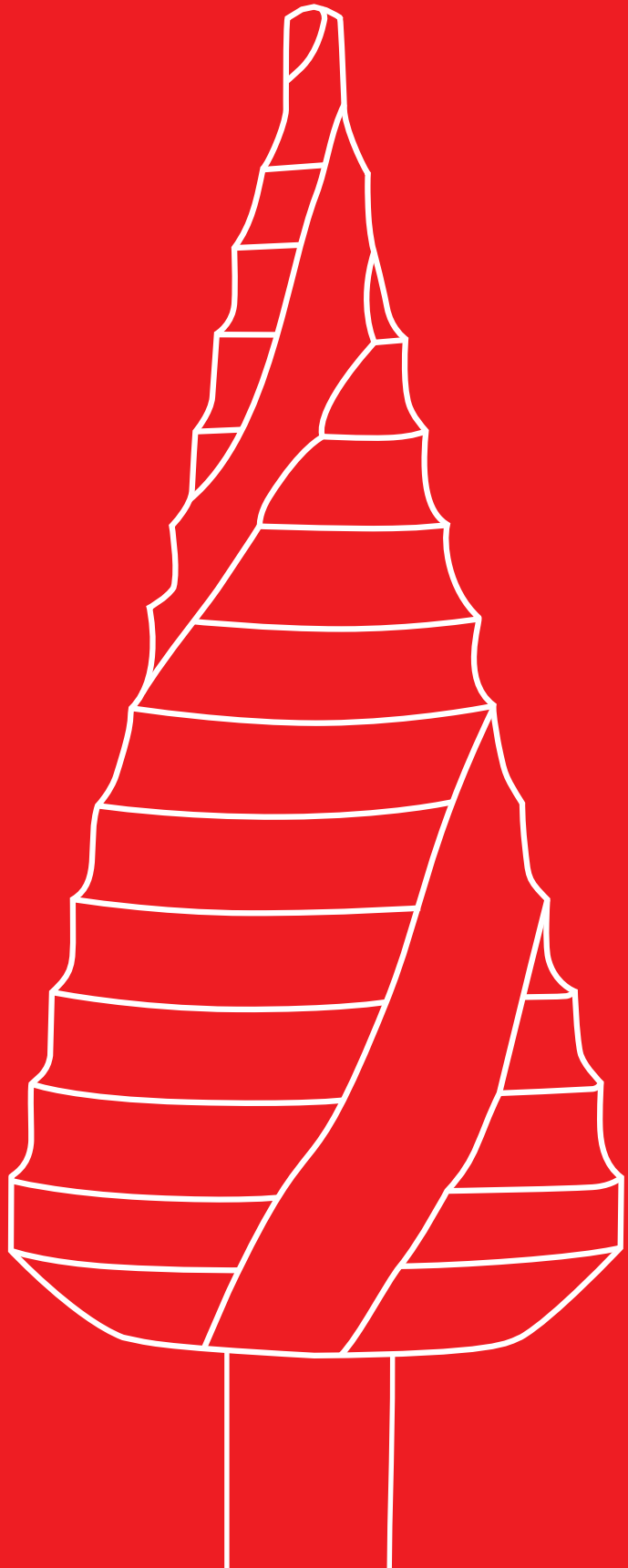

Table of cutting speeds for sheet drills

Material:		High carbon struc. steel up to 700 N/mm ²	High carbon struc. steel over 700 N/mm ²	Alloyed steel over 1000 N/mm ²	Cast iron up to 250 N/mm ²	Cast iron over 250 N/mm ²	CuZn-alloy brittle	CuZn-alloy tough	Al-alloy up to 11% Si	Thermo-plastics	Duro-plastics
Sheet thickness:		up to 4.0	up to 4.0	up to 4.0	up to 4.0	up to 4.0	up to 4.0	up to 4.0	up to 4.0	up to 4.0	up to 4.0
Vc = m/min		30	20	20	15	10	60	35	30	20	15
Cooling lubricant:		Cutting spray	Cutting spray	Cutting spray	Cutting spray	Air	Air	Air	Cutting spray	Water	Air
Size	Ø mm	n = r.p.m.	n = r.p.m.	n = r.p.m.	n = r.p.m.	n = r.p.m.	n = r.p.m.	n = r.p.m.	n = r.p.m.	n = r.p.m.	n = r.p.m.
No. 1	3.0-14.0	3185-682	2123-455	2123-455	1592-341	1062-227	6369-1365	3715-796	3185-682	2123-455	1592-341
No. 2	4.0-20.0	1911-478	1274-318	1274-318	955-239	637-159	3822- 955	2229-557	1911-478	1274-318	955-239
No. 3	16.0-30.5	597-313	398-209	398-209	299-157	199-104	1194- 627	697-365	597-313	398-209	299-157
No. 4	24.0-40.0	398-239	265-159	265-159	199-119	133- 80	796- 478	464-279	398-239	265-159	199-119
No. 5	36.0-50.0	265-191	177-127	177-127	133- 96	88- 64	531- 382	310-223	265-191	177-127	133- 96
No. 6	40.0-61.0	239-157	159-104	159-104	119- 78	80- 52	478- 313	279-183	239-157	159-104	119- 78
No. 7	5.0-25.4	1911-376	1274-251	1274-251	955-188	637-125	3822- 752	2229-439	1911-376	1274-251	955-188
No. 8	5.0-31.0	1911-308	1274-205	1274-205	955-154	637-103	3822- 616	2229-360	1911-308	1274-205	955-154
No. 9	5.0-22.5	1911-425	1274-283	1274-283	955-212	637-142	3822- 849	2229-495	1911-425	1274-283	955-212



04



STEP DRILLS

Type and applications overview	76 – 79
ULTIMATECUT HSSE-Co 5 + RUnaTEC, spiral fluted with FLOWSTEP® tip	80
ULTIMATECUT HSS + RUnaTEC, spiral fluted with FLOWSTEP® tip	81
HSS + TiN + TiAlN + HSSE-Co 5, spiral fluted with spiral fluted	82 – 83
Crash barrier step drill HSS TiAlN, spiral fluted	83
Bit HSS + TiN, spiral fluted	84
HSS, spiral fluted – <i>short</i>	84
HSS + TiN + TiAlN + HSSE-Co 5, spiral fluted – <i>inch dimensions</i>	85
HSS + TiN, with 3 cutting edges, straight groove	86
HSS + TiN + TiAlN spiral fluted, for metric cable connections	87
Reamer HSS, without tip	87
Subland drill type N, HSS	88
Short subland drill type N, HSS	89
Table of cutting speeds for step drills	90
Table of application for step drills	91
ULTIMATECUT Multidrill HSS RUnaTEC	94

ULTIMATECUT[®]

Step drill with FLOWSTEP[®] tip

It lets you drill 6x more.
It lets you drill 75% faster.
It lets you center perfectly.



RUKO FLOWSTEP[®] tip

Precise centring = no slipping when drilling.
Time saving due to faster drilling = drill more holes in the same time.
Energy-saving drilling = drill more holes without stopping.

**RUna
TEC**

RUKO RUnaTEC coating

Thanks to RUKO nano Technology (RUnaTEC), very high cutting speeds can be achieved in addition to low cutting speeds, thus significantly accelerating work processes.

Other positive properties are the extremely high wear resistance and the significant reduction in material welding.

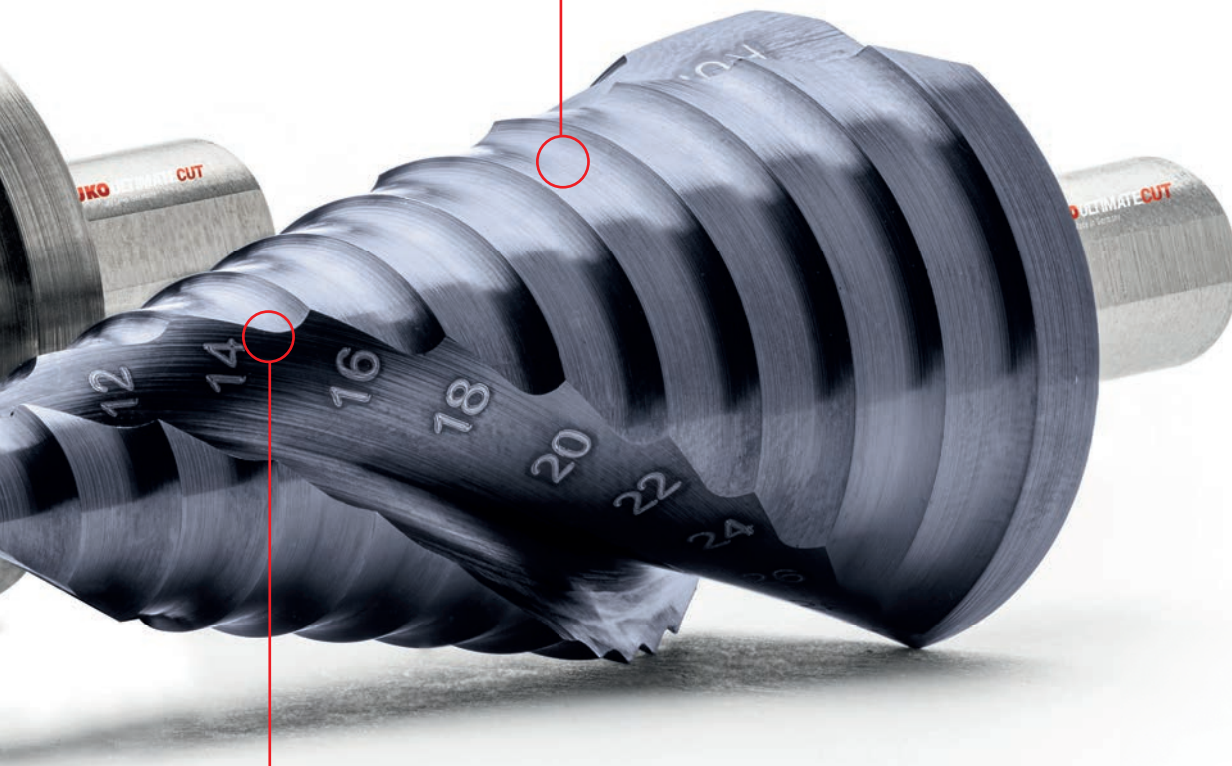

RUKO FLOWSTEP® Technology

Controllable on sensitive materials such as thin-walled sheet metal and acrylic glass. Powerful with tough materials such as stainless steel.

The cutting edge geometry enables a smooth, seamless transition between the different diameters.

Type and applications overview

04



























	Material	Surface	Cutting edges	Material thickness	Point angle	Point cut	Shank	Ø mm	Item no.	Page/s
	NEW HSSE Co5	RUna TEC						5 - 38	101 6xx EP	80
	HSSE Co5	Blank							101 6xx E	
	HSS	RUna TEC							101 6xx	81
	HSS	Blank							101 6xx P	
	HSS	RUna TEC						6,0 - 27,0	101 0xx P	94
	HSS	Blank						4,0 - 40,0	101 xxx	82 - 83
	HSSE Co5	Blank						4,0 - 32,5	101 xxx E	
	HSS	TiN						4,0 - 40,0	101 xxx T	
	HSS	TiAlN						4,0 - 40,0	101 xxx F	
	HSS	TiAlN						6,0 - 18,0	101 068 F-1	83
	HSS	Blank						4,0 - 12,0	101 xxx H	84
	HSS	TiN						4,0 - 30,0	101 xxx H	
	HSS	Blank						4,0 - 30,0	101 06x	84
	HSS	TiN						4,0 - 30,0	101 06x T	
	HSS	Blank						3/16 - 1 1/8"	101 70x	85
	HSSE Co5	Blank						3/16 - 1 1/8"	101 70x E	
	HSS	TiN						3/16 - 1 1/8"	101 70x T	
	HSS	TiAlN						3/16 - 1 1/8"	101 70x F	
	HSS	Blank						4,0 - 30,0	101 35x	86
	HSS	TiN						4,0 - 30,0	101 35x T	

Structural steel < 900 N/mm ²	Inox <1100 N/mm ²	High strength steel <1300 N/mm ²	Brass	Bronze	Cast iron	Aluminium	Plastics
●	●	○	●	○	○	●	●
●	●		●	○	○	●	●
●			●	○	○	●	●
●			●			●	●
●	●		●	●	●	○	○
●			●	●	●	○	○
●	●		●	●	●	○	○
●					●	○	○
●	●		●	●	●	○	○
●	●	○	○	●	●	○	○
●				○	●	○	○
●	○	○	○	○	●	○	○
●				○	●	○	○
●	○	○	○	○	●	○	○
●				●	●	○	○
●	●		●	●	●	○	○
●	○		○		●	○	○
●	●	○	○	●	●	○	○
●	●	○	○	●	●	●	○
●				●	●	○	○



Type and applications overview

04

	Material	Surface	Cutting edges	Material thickness	Point angle	Point cut	Shank	Ø mm	Item no.	Page/s
	HSS	Blank		 4 mm	 118°			5,3 – 32,5	101 09x	87
	HSS	TiN		 4 mm	 118°			5,3 – 32,5	101 09x T	
	HSS	TiAlN		 4 mm	 118°			5,3 – 32,5	101 09x F	
	HSS	Blank		 4 mm				12,0 – 40,0	101 36x	87
	HSS	VAP			 118°			M3 – M12	102 6xx	88
	HSS	VAP			 118°				102 6xx	89

Structural steel < 900 N/mm ²	Inox <1100 N/mm ²	High strength steel <1300 N/mm ²	Brass	Bronze	Cast iron	Aluminium	Plastics
●				●	●	○	○
●	○		○		●	○	○
●	●	○	○	●	●	○	○
●				●	●	○	○
●			●	○	○	●	●
●			●	○	○	●	●

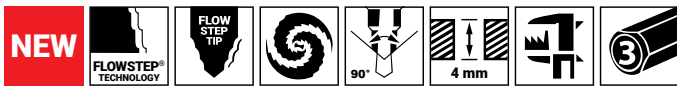

ULTIMATECUT®

ULTIMATECUT step drill HSSE-Co 5, spiral fluted with FLOWSTEP® tip

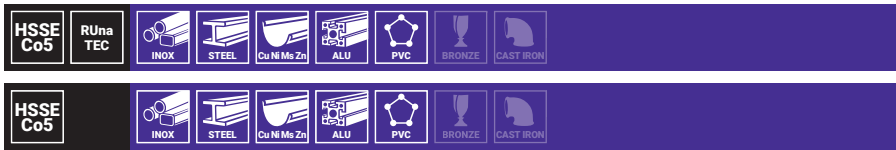

04

FLOWSTEP® tip

- Perfect centering, avoiding slipping even on round surfaces such as pipe and tube.
- Easy and smooth drilling process, without jamming in the material.
- Extremely fast and energy-saving drilling.
- Time savings of up to 75%.
- Significantly longer tool life - up to 6x more holes possible.
- Optimal performance in hand-held (cordless) power tool drill machines.

Packaging: plastic tube

Size no.	Ø1 - Ø2 mm	L1 mm	Steps	Ø3 mm	HSSE-Co 5		HSSE-Co 5 RUnaTEC	
0/9	5.0 - 12.0	66.0	8	6.0	101 650-9 E	1	101 650-9 EP	1
1	6.0 - 20.0	70.0	8	8.0	101 651 E	1	101 651 EP	1
2	8.0 - 30.0	95.0	12	10.0	101 652 E	1	101 652 EP	1
3	9.0 - 38.0	100.0	11	10.0	101 653 E	1	101 653 EP	1

Größe Nr.	Drilling range Ø mm
0/9	5.0 6.0 7.0 8.0 9.0 10.0 11.0 12.0 mm
1	6.0 8.0 10.0 12.0 14.0 16.0 18.0 20.0 mm
2	8.0 10.0 12.0 14.0 16.0 18.0 20.0 22.0 24.0 26.0 28.0 30.0 mm
3	9.0 13.0 16.0 19.0 21.0 23.0 26.0 29.0 32.0 35.0 38.0 mm

		HSSE-Co 5	HSSE-Co 5 RUnaTEC
3 tfg./pcs.	ULTIMATECUT step drill set with FLOWSTEP® tip spiral fluted, sizes 0/9, 1, 2	101 626 ERO	101 626 EPRO





ULTIMATECUT®

ULTIMATECUT step drill HSS, spiral fluted with FLOWSTEP® tip

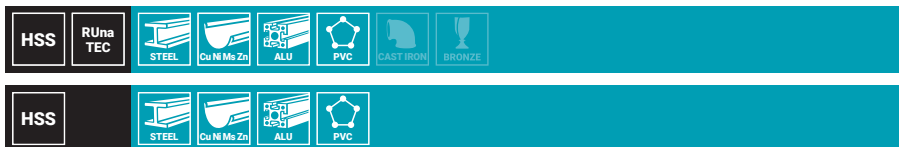

FLOWSTEP® tip

- Perfect centering, avoiding slipping even on round surfaces such as pipe and tube.
- Easy and smooth drilling process, without jamming in the material.
- Extremely fast and energy-saving drilling.
- Time savings of up to 75%.
- Significantly longer tool life - up to 6x more holes possible.
- Optimal performance in hand-held (cordless) power tool drill machines.



Packaging: plastic tube

Size no.	Ø1 - Ø2 mm	L1 mm	Steps	Ø3 mm	HSS	HSS RUnaTEC
0/9	5.0 - 12.0	66.0	8	6.0	101 650-9	101 650-9 P
1	6.0 - 20.0	70.0	8	8.0	101 651	101 651 P
2	8.0 - 30.0	95.0	12	10.0	101 652	101 652 P
3	9.0 - 38.0	1.30	38.0	16.0	101 653	101 653 P

Größe Nr.	Drilling range Ø mm
0/9	5.0 6.0 7.0 8.0 9.0 10.0 11.0 12.0 mm
1	6.0 8.0 10.0 12.0 14.0 16.0 18.0 20.0 mm
2	8.0 10.0 12.0 14.0 16.0 18.0 20.0 22.0 24.0 26.0 28.0 30.0 mm
3	9.0 13.0 16.0 19.0 21.0 23.0 26.0 29.0 32.0 35.0 38.0 mm

	HSS	HSS RUnaTEC
3 tfg. pcs.	101 626 RO	101 626 PRO



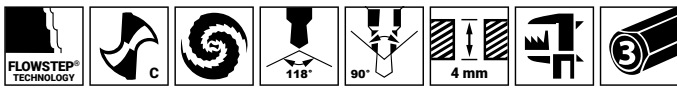

Step drill HSS and HSSE-Co 5, spiral fluted

HSSE Co5	INOX	STEEL	Cu Ni Ms Zn	ALU	PVC	BRONZE	CAST IRON	
HSS	TiAIN	INOX	STEEL	Cu Ni Ms Zn	ALU	PVC	BRONZE	CAST IRON
HSS	TiN	STEEL	Cu Ni Ms Zn	PVC	INOX	CAST IRON	BRONZE	
HSS		STEEL	Cu Ni Ms Zn	ALU	PVC	CAST IRON	BRONZE	



The step drill with specially developed FLOWSTEP® technology enables seamless transitions between the different diameters. Each individual step has a specially developed undercut that guides the step drill seamlessly and in a controlled manner to the next step after drilling through each step. This enables a noticeably smoother and quieter drilling process. The deep-ground and spiral-shaped flute offers absolutely smooth running and high cutting performance.

In particular, non-breaking chips are removed cleanly as with a twist drill. This minimises the formation of built-up edges and cold welding on the cutting edges. The cone facilitates retraction when drilling through sheet metal.

Packaging: plastic tube

Size no.	Ø1 - Ø2 mm	L1 mm	Steps	Ø3 mm	HSSE-Co 5	HSS TiAIN	HSS TiN	HSS	
0/5	4.0 - 12.0	65.0	5	6.0	—	101 050-5 F	101 050-5 T	101 050-5	1
0/9	4.0 - 12.0	65.0	9	6.0	101 050-9 E	101 050-9 F	101 050-9 T	101 050-9	1
1	4.0 - 20.0	75.0	9	8.0	101 051 E	101 051 F	101 051 T	101 051	1
2	4.0 - 30.0	100.0	14	10.0	101 052 E	101 052 F	101 052 T	101 052	1
3	6.0 - 38.0	100.0	12	10.0	—	101 053 F	101 053 T	101 053	1
4	6.0 - 26.75	75.0	8	10.0	—	101 055 F	101 055 T	101 055	1
5	4.0 - 39.0	107.0	13	10.0	101 056 E	101 056 F	101 056 T	101 056	1
6	6.0 - 32.0	75.0	8	10.0	—	101 057 F	101 057 T	101 057	1
7	5.0 - 28.0	69.0	7	10.0	—	101 058 F	101 058 T	101 058	1
8	6.0 - 30.5	80.0	9	10.0	—	101 098 F	101 098 T	101 098	1
9	6.0 - 37.0	100.0	12	10.0	101 060 E	101 060 F	101 060 T	101 060	1
12	6.0 - 32.0	76.0	9	10.0	—	101 096 F	101 096 T	101 096	1
13	6.0 - 40.0	105.0	16	13.0	—	101 097 F*	101 097 T*	101 097*	1
18	6.5 - 32.5	91.0	12	10.0	101 534 E	—	—	—	1

* straight flute

Size no.	Drilling range Ø mm
0/5	4.0 6.0 8.0 10.0 12.0 mm
0/9	4.0 5.0 6.0 7.0 8.0 9.0 10.0 11.0 12.0 mm
1	4.0 6.0 8.0 10.0 12.0 14.0 16.0 18.0 20.0 mm
2	4.0 6.0 8.0 10.0 12.0 14.0 16.0 18.0 20.0 22.0 24.0 26.0 28.0 30.0 mm
3	6.0 9.0 13.0 16.0 19.0 21.0 23.0 26.0 29.0 32.0 35.0 38.0 mm
4	6.0 9.0 11.4 (PG7) 14.0 (PG9) 17.25 (PG11) 19.0 (PG13.5) 21.25 (PG16) 26.75 mm (PG21)
5	4.0 6.0 9.0 12.0 15.0 18.0 21.0 24.0 27.0 30.0 33.0 36.0 39.0 mm
6	6.0 9.0 11.2 (R1/8) 14.5 (R1/4) 18.2 (R3/8) 22.3 (R1/2) 27.9 (R3/4) 32.0 mm
7	5.0 8.8 (G1/8) 11.8 (G1/4) 15.3 (G3/8) 19.0 (G1/2) 24.5 (G3/4) 28.0 mm
8	6.0 9.0 12.5 (PG7) 15.2 (PG9) 18.6 (PG11) 20.4 (PG13.5) 22.5 (PG16) 28.3 (PG21) 30.5 mm
9	6.0 9.0 12.5 (PG7) 15.2 (PG9) 18.6 (PG11) 20.4 (PG13.5) 22.5 (PG16) 26.0 28.3 (PG21) 30.5 34.0 37.0 mm (PG29)
12	6.0 9.0 12.0 16.0 20.0 22.5 25.0 28.5 32.0 mm
13	6.0 11.0 17.0 23.0 29.0 30.0 31.0 32.0 33.0 34.0 35.0 36.0 37.0 38.0 39.0 40.0 mm
18	6.5 8.5 10.5 12.7 15.2 (PG9) 16.2 18.6 (PG11) 20.4 (PG13.5) 22.5 (PG16) 25.5 28.3 (PG21) 32.5 mm

		HSS	HSSE-Co 5	HSS TiN	HSS TiAlN
3 tfg./pos.	Step drill set spiral fluted, sizes 0/9, 1, 2	101 026 RO	101 026 ERO	101 026 TRO	101 026 FRO



101 026 RO



101 026 TRO



101 026 FRO

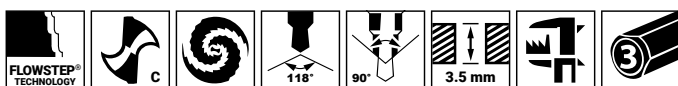

Crash barrier step drill HSS TiAlN, spiral fluted

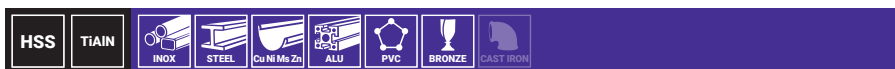

Specially designed for drilling crash barriers.
For use on material strengths of up to 3,5 mm.
Cooling recommended but not required (increased service life)

Packaging: plastic tube



Ø1 - Ø2 mm		L1 mm	Steps	Ø3 mm	HSS TiAlN	
6.0 - 18.0	6.0 8.0 10.0 12.0 14.0 16.0 18.0 mm	68,0	7	10,0	101 068 F-1	1

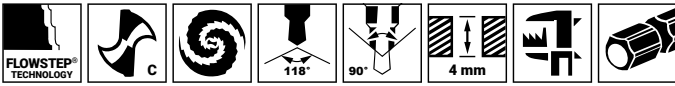

Step drill bit HSS, spiral fluted

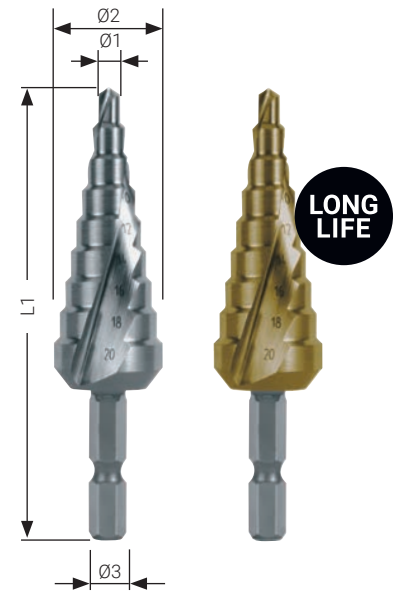
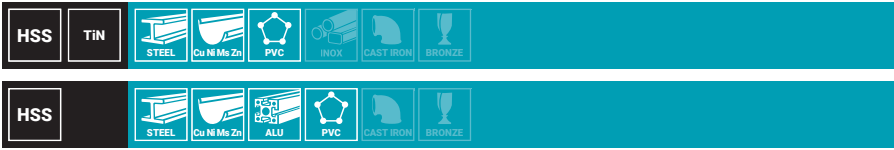

04

The CBN ground and spiral flutes guarantee quiet running and high cutting performance. Especially the chip flow is optimized, so even long, non-breaking chips will be removed easily. The optimized chip flow protects the cutting edges and reduces built-up edges and cold weld marks. The chamfer on the base of the cone makes withdrawal of the tool from the material simple when through hole drilling.

Packaging: plastic tube

Size no.	Ø1 - Ø2 mm	L1 mm	Steps	Ø3 mm	Ø3 inch	HSS TiN	HSS	
0/9	4.0 - 12.0	72.0	9	6.35 x 27.0	1/4"	101 050-9 TH	101 050-9 H	1
1	4.0 - 20.0	81.0	9	6.35 x 27.0	1/4"	101 051 TH	101 051 H	1
2	4.0 - 30.0	105.0	14	6.35 x 27.0	1/4"	101 052 TH	101 052 H	1

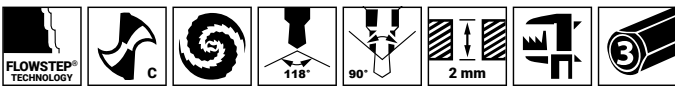

Step drill HSS, spiral fluted – short

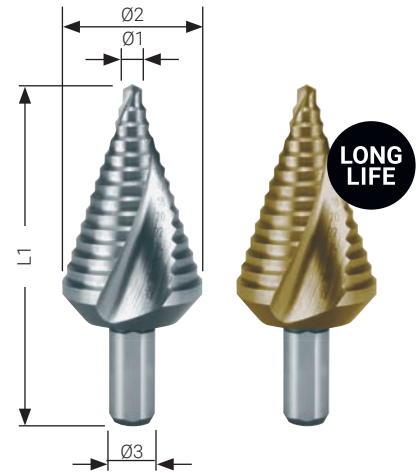

Packaging: plastic tube

Size no.	Ø1 - Ø2 mm	L1 mm	Steps	Ø3 mm	HSS TiN	HSS	
0/9k	4.0 - 12.0	48.0	9	6.0	101 061 T	101 061	1
1k	4.0 - 20.0	58.0	9	8.0	101 062 T	101 062	1
2k	4.0 - 30.0	72.0	14	10.0	101 063 T	101 063	1

Size no.	Drilling range Ø mm
0/9	4.0 5.0 6.0 7.0 8.0 9.0 10.0 11.0 12.0 mm
1	4.0 6.0 8.0 10.0 12.0 14.0 16.0 18.0 20.0 mm
2	4.0 6.0 8.0 10.0 12.0 14.0 16.0 18.0 20.0 22.0 24.0 26.0 28.0 30.0 mm

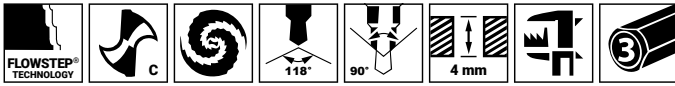

Step drill HSS and HSSE-Co 5, spiral fluted – inch dimensions

HSSE Co5	INOX	STEEL	Cu Ni Ms Zn	ALU	PVC	BRONZE	CAST IRON
HSS TiAlN	INOX	STEEL	Cu Ni Ms Zn	ALU	PVC	BRONZE	CAST IRON
HSS TiN	STEEL	Cu Ni Ms Zn	PVC	INOX	CAST IRON	BRONZE	
HSS	STEEL	Cu Ni Ms Zn	ALU	PVC	CAST IRON	BRONZE	

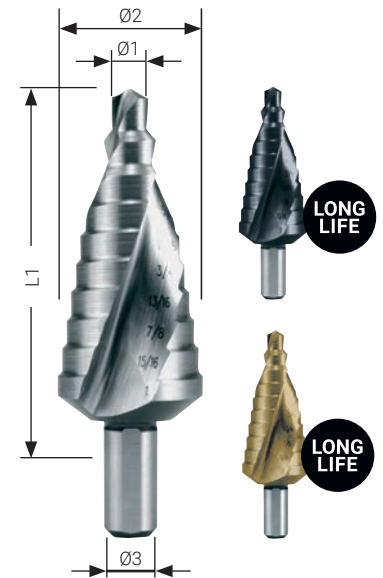

Inch Size

The deep-ground and spiral flute offers absolutely smooth running and high cutting performance. In particular, non-breaking chips are removed cleanly as with a twist drill. This minimises the formation of built-up edges and cold welding on the cutting edges. The cone facilitates retraction when drilling through sheet metal.

Packaging: plastic tube

Size no.	Ø1 - Ø2 inch	L1 inch	Steps	Ø3 inch	HSSE-Co 5	HSS TiAlN	HSS TiN	HSS	
1	3/16" - 1/2"	3 1/8"	6	1/4"	101 701 E	101 701 F	101 701 T	101 701	1
2	1/8" - 1/2"	3 1/8"	13	1/4"	101 702 E	101 702 F	101 702 T	101 702	1
3	1/4" - 3/4"	2 3/4"	9	3/8"	101 703 E	101 703 F	101 703 T	101 703	1
4	3/16" - 7/8"	3 1/4"	12	3/8"	101 704 E	101 704 F	101 704 T	101 704	1
5	5/16" - 1"	3 1/4"	9	3/8"	101 705 E	101 705 F	101 705 T	101 705	1
6	7/8" - 1 3/8"	3 1/4"	5	3/8"	101 706 E	101 706 F	101 706 T	101 706	1
7	3/8" - 1/2"	1 7/8"	2	1/4"	101 707 E	101 707 F	101 707 T	101 707	1
8	7/8"	2 19/32"	1	3/8"	101 708 E	101 708 F	101 708 T	101 708	1
9	7/8" - 1 1/8"	3 7/64"	2	3/8"	101 709 E	101 709 F	101 709 T	101 709	1

Size no.	Drilling range Ø inch
1	3/16" 1/4" 5/16" 3/8" 7/16" 1/2"
2	1/8" 5/32" 3/16" 7/32" 1/4" 9/32" 5/16" 11/32" 3/8" 19/32" 3/16" 15/32" 1/2"
3	1/4" 5/16" 3/8" 7/16" 1/2" 9/16" 5/8" 11/16" 3/4"
4	3/16" 1/4" 5/16" 3/8" 7/16" 1/2" 9/16" 5/8" 11/16" 3/4" 13/16" 7/8"
5	5/16" 1/2" 9/16" 5/8" 11/16" 3/4" 13/16" 7/8" 15/16" 1"
6	7/8" 1 1/8" 1 7/32" 1 1/4" 1 3/8"
7	3/8" 1/2"
8	7/8"
9	7/8" 1 1/8"

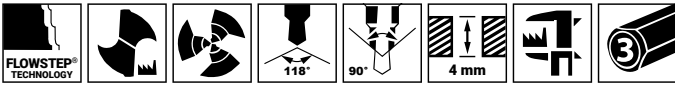

Step drill HSS, with 3 cutting edges, straight groove

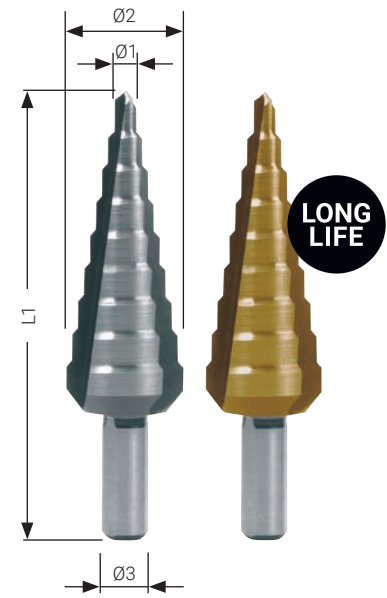
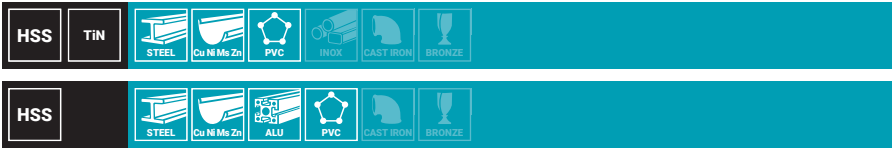

The deep-ground flutes on step drills with 3 cutting edges ensure absolutely chatter-free work. Due to the lower cutting edge load, a higher feed rate is possible, especially with soft materials such as non-ferrous metals. The cone facilitates retraction when drilling through sheet metal.

Packaging: plastic tube

Size no.	Ø1 - Ø2 mm	L1 mm	Steps	Ø3 mm	HSS TiN	HSS	
0/9	4.0 - 12.0	65.0	9	6.0	101 350-9 T	101 350-9	1
1	4.0 - 20.0	75.0	9	8.0	101 351 T	101 351	1
2	4.0 - 30.0	100.0	14	10.0	101 352 T	101 352	1

Size no.	Drilling range Ø mm
0/9	4.0 5.0 6.0 7.0 8.0 9.0 10.0 11.0 12.0 mm
1	4.0 6.0 8.0 10.0 12.0 14.0 16.0 18.0 20.0 mm
2	4.0 6.0 8.0 10.0 12.0 14.0 16.0 18.0 20.0 22.0 24.0 26.0 28.0 30.0 mm

		HSS TiN	HSS
3 fig./pcs.	Step drill set with 3 cutting edges, sizes 0/9, 1, 2	101 326 TRO	101 326 RO



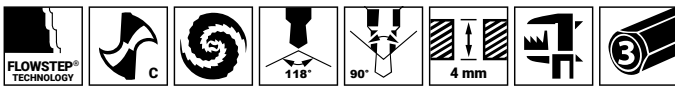

Step drill HSS, spiral fluted, for metric cable connections

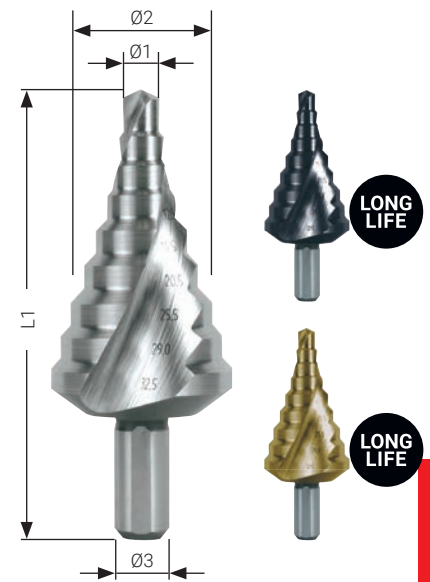
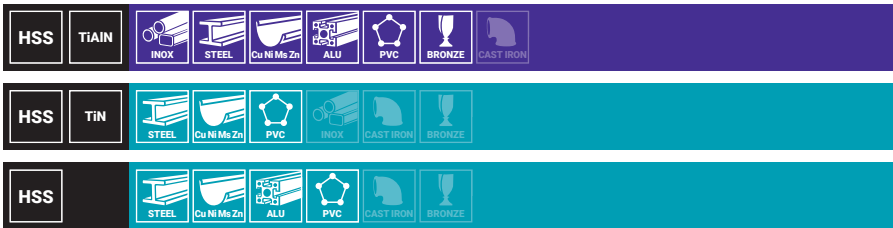

04

Packaging: plastic tube

Size no.	Measurements	Ø1 - Ø2 mm	L1 mm	Steps	Ø3 mm	HSS TiAlN	HSS TiN	HSS	
14	Core holes	5.3 - 30.5	79.0	9	10.0	101 093 F	101 093 T	101 093	1
15	Through holes	6.5 - 32.5	79.0	9	10.0	101 092 F	101 092 T	101 092	1
16	Core holes	5.3 - 38.5	96.0	11	10.0	101 091 F	101 091 T	101 091	1
17	Through holes	6.5 - 40.5	96.0	11	10.0	101 090 F	101 090 T	101 090	1

14	DIN/EN 60423	5.3 7.0 9.0 10.5 14.5 18.5 23.5 27.0 30.5
15	DIN/EN 50262	6.5 8.5 10.5 12.5 16.5 20.5 25.5 29.0 32.5
16	DIN/EN 60423	5.3 7.0 9.0 10.5 14.5 18.5 23.5 27.0 30.5 34.5 38.5
17	DIN/EN 50262	6.5 8.5 10.5 12.5 16.5 20.5 25.5 29.0 32.5 36.5 40.5



Step drill (reamer) HSS, without tip

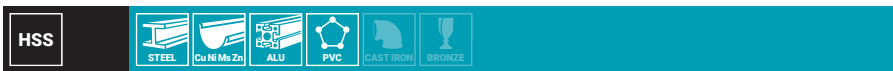

Packaging: plastic tube

Size no.	Ø1 - Ø2 mm	L1 mm	Steps	Ø3 mm	HSS	
20	12.0 - 20.0	66.0	9	8.0	101 361	1
30	20.0 - 30.0	78.0	11	10.0	101 362	1
40	30.0 - 40.0	78.0	11	10.0	101 363	1

Size no.	Drilling range Ø mm
20	12.0 13.0 14.0 15.0 16.0 17.0 18.0 19.0 20.0 mm
30	20.0 21.0 22.0 23.0 24.0 25.0 26.0 27.0 28.0 29.0 30.0 mm
40	30.0 31.0 32.0 33.0 34.0 35.0 36.0 37.0 38.0 39.0 40.0 mm

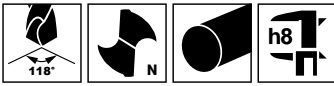

Subland drill type N HSS



Enables drilling and sinking combined in one step. Note: adjust the cutting speed according to the big diameter and the feed rate according to the small diameter.

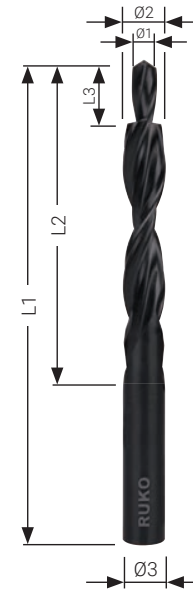

04

Packaging: plastic tube



90° fine grade for through hole

For efficient drilling of through holes and screw head counterborings with 90° angle.

For thread	Ø1 mm	Ø2 / Ø3 mm	L3 mm	L2 mm	L1 mm	HSS	
M 3	3.2	6.0	9.0	57.0	93.0	102 601	1
M 4	4.3	8.0	11.0	75.0	117.0	102 602	1
M 5	5.3	10.0	13.0	87.0	133.0	102 603	1
M 6	6.4	11.5	15.0	94.0	142.0	102 604	1
M 8	8.4	15.0	19.0	114.0	169.0	102 605	1
M 10	10.5	19.0	23.0	135.0	198.0	102 606	1



180° medium grade for through hole

For efficient drilling of through holes and screw head counterborings with 180° angle.

For thread	Ø1 mm	Ø2 / Ø3 mm	L3 mm	L2 mm	L1 mm	HSS	
M 3	3.4	6.0	9.0	57.0	93.0	102 607	1
M 4	4.5	8.0	11.0	75.0	117.0	102 608	1
M 5	5.5	10.0	13.0	87.0	133.0	102 609	1
M 6	6.6	11.0	15.0	94.0	142.0	102 610	1
M 8	9.0	15.0	19.0	114.0	169.0	102 611	1
M 10	11.0	18.0	23.0	130.0	191.0	102 612	1



90° for thread core hole

For efficient drilling of tapping holes and countersinkings with 90° angle.

For thread	Ø1 mm	Ø2 / Ø3 mm	L3 mm	L2 mm	L1 mm	HSS	
M 3	2.5	3.4	8.8	39.0	70.0	102 613	1
M 4	3.3	4.5	11.4	47.0	80.0	102 614	1
M 5	4.2	5.5	13.6	57.0	93.0	102 615	1
M 6	5.0	6.6	16.5	63.0	101.0	102 616	1
M 8	6.8	9.0	21.0	81.0	125.0	102 617	1
M 10	8.5	11.0	25.5	94.0	142.0	102 618	1
M 12	10.2	13.5	30.0	108.0	160.0	102 619	1

Short subland drill type N HSS



Short and torsion stable drill, suitable for the use on CNC or NC machines. The drilling and countersinking is made in one step. Note: adjust the cutting speed according to the big diameter and the feed rate according to the small diameter.

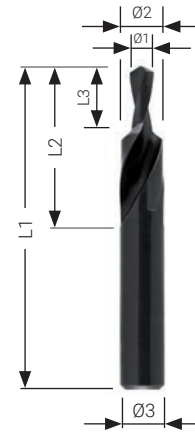

Packaging: plastic tube



90° fine grade for through hole

For efficient drilling of through holes and screw head counterborings with 90° angle.

For thread	Ø1 mm	Ø2 / Ø3 mm	L3 mm	L2 mm	L1 mm	HSS	
M 3	3,2	6,0	9,0	28,0	66,0	102 620	1
M 4	4,3	8,0	11,0	37,0	79,0	102 621	1
M 5	5,3	10,0	13,0	43,0	89,0	102 622	1
M 6	6,4	11,5	15,0	47,0	95,0	102 623	1
M 8	8,4	15,0	19,0	56,0	111,0	102 624	1
M 10	10,5	19,0	23,0	64,0	127,0	102 625	1

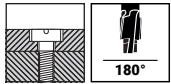

180° medium grade for through hole

For efficient drilling of through holes and screw head counterborings with 180° angle.

For thread	Ø1 mm	Ø2 / Ø3 mm	L3 mm	L2 mm	L1 mm	HSS	
M 3	3,4	6,0	9,0	28,0	66,0	102 626	1
M 4	4,5	8,0	11,0	37,0	79,0	102 627	1
M 5	5,5	10,0	13,0	43,0	89,0	102 628	1
M 6	6,6	11,0	15,0	47,0	95,0	102 629	1
M 8	9,0	15,0	19,0	56,0	111,0	102 630	1
M 10	11,0	18,0	23,0	62,0	123,0	102 631	1



90° for thread core hole

For efficient drilling of tapping holes and countersinkings with 90° angle.

For thread	Ø1 mm	Ø2 / Ø3 mm	L3 mm	L2 mm	L1 mm	HSS	
M 3	2,5	3,4	8,8	20,0	52,0	102 632	1
M 4	3,3	4,5	11,4	24,0	58,0	102 633	1
M 5	4,2	5,5	13,6	28,0	66,0	102 634	1
M 6	5,0	6,6	16,5	31,0	70,0	102 635	1
M 8	6,8	9,0	21,0	40,0	84,0	102 636	1
M 10	8,5	11,0	25,5	47,0	95,0	102 637	1
M 12	10,2	13,5	30,0	54,0	107,0	102 638	1

Table of cutting speeds for step drills

Material:		High carbon struc. steel up to 700 N/mm ²	High carbon struc. steel over 700 N/mm ²	Alloyed steel over 1000 N/mm ²	Cast iron up to 250 N/mm ²	Cast iron over 250 N/mm ²	CuZn-alloy brittle	CuZn-alloy tough	Al-alloy up to 11% Si	Thermo-plastics	Duro-plastics
Sheet thickness mm:		up to 4.0	up to 4.0	up to 4.0	up to 4.0	up to 4.0	up to 4.0	up to 4.0	up to 4.0	up to 4.0	up to 4.0
Vc = m/min		30	20	20	15	10	60	35	30	20	15
Cooling lubricant:		Cutting spray	Cutting spray	Cutting spray	Air	Air	Air	Air	Cutting spray	Water	Air
Size	Ø mm	n = r.p.m	n = r.p.m	n = r.p.m	n = r.p.m	n = r.p.m	n = r.p.m	n = r.p.m	n = r.p.m	n = r.p.m	n = r.p.m
0/5	4.0 - 12.0	800 - 2400	500 - 1600	500 - 1600	400 - 1200	300 - 800	1600 - 4800	900 - 2800	800 - 2400	500 - 1600	400 - 1200
0/9	4.0 - 12.0	800 - 2400	500 - 1600	500 - 1600	400 - 1200	300 - 800	1600 - 4800	900 - 2800	800 - 2400	500 - 1600	400 - 1200
1	4.0 - 20.0	500 - 2400	300 - 1600	300 - 1600	200 - 1200	200 - 800	1000 - 4800	600 - 2800	500 - 2400	300 - 1600	200 - 1200
2	4.0 - 30.0	300 - 2400	200 - 1600	200 - 1600	200 - 1200	100 - 800	600 - 4800	400 - 2800	300 - 2400	200 - 1600	200 - 1200
3	6.0 - 38.0	300 - 1600	200 - 1100	200 - 1100	100 - 800	100 - 500	500 - 3200	300 - 1900	300 - 1600	200 - 1100	100 - 800
4	6.0 - 26.8	400 - 1600	200 - 1100	200 - 1100	200 - 800	100 - 500	700 - 3200	400 - 1900	400 - 1600	200 - 1100	200 - 800
5	4.0 - 32.0	300 - 2400	200 - 1600	200 - 1600	1200 - 100	100 - 800	600 - 4800	300 - 2800	300 - 2400	200 - 1600	100 - 1200
6	6.0 - 32.0	300 - 1600	200 - 1100	200 - 1100	800 - 100	100 - 500	600 - 3200	300 - 1900	300 - 1600	200 - 1100	100 - 800
7	5.0 - 28.0	300 - 1900	200 - 1300	200 - 1300	200 - 1000	100 - 600	700 - 3800	400 - 2200	300 - 1900	200 - 1300	200 - 1000
8	6.0 - 30.5	300 - 1600	200 - 1100	200 - 1100	200 - 800	100 - 500	600 - 3200	400 - 1900	300 - 1600	200 - 1100	200 - 800
9	6.0 - 37.0	300 - 1600	200 - 1100	200 - 1100	100 - 800	100 - 500	500 - 3200	300 - 1900	300 - 1600	200 - 1100	100 - 800
10	4.8 - 10.7	900 - 2000	600 - 1300	600 - 1300	400 - 1000	300 - 700	1800 - 4000	1000 - 2300	900 - 2000	600 - 1300	400 - 1000
11	6.0 - 25.0	400 - 1600	300 - 1100	300 - 1100	200 - 800	100 - 500	800 - 3200	400 - 1900	400 - 1600	300 - 1100	200 - 800
12	6.0 - 32.0	300 - 1600	200 - 1100	200 - 1100	100 - 800	100 - 500	600 - 3200	300 - 1900	300 - 1600	200 - 1100	100 - 800
13	6.0 - 40.0	200 - 1600	200 - 1100	200 - 1100	100 - 800	100 - 500	500 - 3200	300 - 1900	200 - 1600	200 - 1100	100 - 800
14	5.3 - 30.5	300 - 1800	200 - 1200	200 - 1200	200 - 900	100 - 600	600 - 3600	400 - 2100	300 - 1800	200 - 1200	200 - 900
15	6.5 - 32.5	300 - 1500	200 - 1000	200 - 1000	100 - 700	100 - 500	600 - 2900	300 - 700	300 - 1500	200 - 1000	100 - 700
16	5.3 - 38.5	200 - 1800	200 - 1200	200 - 1200	100 - 900	100 - 600	500 - 3600	300 - 2100	200 - 1800	200 - 1200	100 - 900
17	6.5 - 40.5	200 - 1500	200 - 1000	200 - 1000	100 - 700	100 - 500	500 - 2900	300 - 1700	200 - 1500	200 - 1000	100 - 700
18	6.5 - 32.5	300 - 1500	200 - 1000	200 - 1000	100 - 700	100 - 500	600 - 2900	300 - 1700	300 - 1500	200 - 1000	100 - 700
20	12.0 - 20.0	500 - 800	300 - 500	300 - 500	200 - 400	200 - 300	600 - 1600	600 - 900	500 - 800	300 - 500	200 - 400
30	20.0 - 30.0	300 - 500	200 - 300	200 - 300	200 - 200	100 - 200	600 - 1000	400 - 600	300 - 500	200 - 300	200 - 200
40	30.0 - 40.0	200 - 300	200 - 200	200 - 200	100 - 200	100 - 100	500 - 600	300 - 400	200 - 300	200 - 200	100 - 200

Size	Ø inch	n = r.p.m	n = r.p.m	n = r.p.m	n = r.p.m	n = r.p.m	n = r.p.m	n = r.p.m	n = r.p.m	n = r.p.m	n = r.p.m
1	3/16 - 1/2	800 - 2000	500 - 1300	1300 - 500	400 - 1000	300 - 700	1500 - 4000	900 - 2300	800 - 2000	500 - 1300	400 - 1000
2	1/8 - 1/2	800 - 3000	500 - 2000	2000 - 500	400 - 1500	300 - 1000	1500 - 6000	900 - 3500	800 - 3000	500 - 2000	400 - 1500
3	1/4 - 3/4	500 - 1500	300 - 1000	1000 - 300	300 - 800	200 - 500	1000 - 3000	600 - 1800	500 - 1500	300 - 1000	300 - 800
4	3/16 - 7/8	400 - 2000	300 - 1300	1300 - 300	200 - 1000	100 - 700	900 - 4000	500 - 2300	400 - 2000	300 - 1300	200 - 1000
5	5/16 - 1	400 - 1200	300 - 800	800 - 300	200 - 600	100 - 400	800 - 2400	400 - 1400	400 - 1200	300 - 800	200 - 600
6	7/8 - 1 3/8	300 - 400	200 - 300	300 - 200	100 - 200	100 - 100	500 - 900	300 - 500	300 - 400	200 - 300	100 - 200
7	3/8 - 1/2	800 - 1000	500 - 700	700 - 500	400 - 500	300 - 300	1500 - 2000	900 - 1200	800 - 1000	500 - 700	400 - 500
8	7/8	400	300	300	200	100	900	500	400	300	200
9	7/8 - 1 1/8	300 - 400	200 - 300	300 - 200	200 - 200	100 - 100	700 - 900	400 - 500	300 - 400	200 - 300	200 - 200



04

Table of application for step drills

Size No.	Drilling range Ø mm													
0/5	for metric hole diameters													
	Ø 4.0	Ø 6.0	Ø 8.0	Ø 10.0	Ø 12.0									
0/9	for metric hole diameters													
	Ø 4.0	Ø 5.0	Ø 6.0	Ø 7.0	Ø 8.0	Ø 9.0	Ø 10.0	Ø 11.0	Ø 12.0					
1	for metric hole diameters													
	Ø 4.0	Ø 6.0	Ø 8.0	Ø 10.0	Ø 12.0	Ø 14.0	Ø 16.0	Ø 18.0	Ø 20.0					
2	for metric hole diameters													
	Ø 4.0	Ø 6.0	Ø 8.0	Ø 10.0	Ø 12.0	Ø 14.0	Ø 16.0	Ø 18.0	Ø 20.0	Ø 22.0	Ø 24.0	Ø 26.0	Ø 28.0	Ø 30.0
3	for metric hole diameters													
	Ø 6.0	Ø 9.0	Ø 13.0	Ø 16.0	Ø 19.0	Ø 21.0	Ø 23.0	Ø 26.0	Ø 29.0	Ø 32.0	Ø 35.0	Ø 38.0		
4	for steel conduit threads (core holes)													
	PG 7 / Ø 11.4		PG 9 / Ø 14.0		PG 11 / Ø 17.25		PG 13.5 / Ø 19.0		PG 16 / Ø 21.25		PG 21 / Ø 26.75			
5	for metric hole diameters													
	Ø 4.0	Ø 6.0	Ø 9.0	Ø 12.0	Ø 15.0	Ø 18.0	Ø 21.0	Ø 24.0	Ø 27.0	Ø 30.0	Ø 33.0	Ø 36.0	Ø 39.0	
6	for pipe threads (external Ø. through holes)													
	R 1/8" / Ø 11.2		R 1/4" / 14.5		R 3/8" / Ø 18.2		R 1/2" / Ø 22.3		R 3/4" / Ø 27.9					
7	for pipe threads (core holes)													
	G 1/8" / Ø 8.8		G 1/4" / 11.8		G 3/8" / Ø 15.3		G 1/2" / Ø 19.0		G 3/4" / Ø 24.5					
8	for steel conduit threads (through holes)													
	PG 7 / Ø 12.5		PG 9 / Ø 15.2		PG 11 / Ø 18.6		PG 13.5 / Ø 20.4		PG 16 / Ø 22.5		PG 21 / Ø 28.3			
9	for steel conduit threads (through holes)													
	PG 7 / Ø 12.5		PG 9 / Ø 15.2		PG 11 / Ø 18.6		PG 13.5 / Ø 20.4		PG 16 / Ø 22.5		PG 21 / Ø 28.3		PG 29 / Ø 37.0	
10	for blind rivets M3 - M4 - M5 - M6 - M8													
	Ø 4.8	Ø 6.4	Ø 7.2	Ø 9.6	Ø 10.65									
11	for metric hole diameters with high steps													
	Ø 6.0	Ø 9.0	Ø 12.0	Ø 16.0	Ø 20.0	Ø 22.5	Ø 25.0							
12	for metric hole diameters with high steps													
	Ø 6.0	Ø 9.0	Ø 12.0	Ø 16.0	Ø 20.0	Ø 22.5	Ø 25.0	Ø 28.5	Ø 32.0					
13	for metric hole diameters and large diameters													
	Ø 6.0	Ø 11.0	Ø 17.0	Ø 23.0	Ø 29.0	Ø 30.0	Ø 31.0	Ø 32.0	Ø 33.0	Ø 34.0	Ø 35.0	Ø 36.0	Ø 37.0	Ø 38.0
	Ø 39.0	Ø 40.0												
14	for metric cable connections. core holes after DIN/EN 60423													
	M 6	M 8	M 10	M 12	M 16	M 20	M 25	M 32						
	Ø 5.3	Ø 7.0	Ø 9.0	Ø 10.5	Ø 14.5	Ø 18.5	Ø 23.5	Ø 30.5						
15	for metric cable connections. through holes after DIN/EN 50262													
	M 6	M 8	M 10	M 12	M 16	M 20	M 25	M 32						
	Ø 6.5	Ø 8.5	Ø 10.5	Ø 12.5	Ø 16.5	Ø 20.5	Ø 25.5	Ø 32.5						
16	for metric cable connections. core holes after DIN/EN 60423													
	M 6	M 8	M 10	M 12	M 16	M 20	M 25	M 32	M 40					
	Ø 5.3	Ø 7.0	Ø 9.0	Ø 10.5	Ø 14.5	Ø 18.5	Ø 23.5	Ø 30.5	Ø 38.5					
17	for metric cable connections. through holes after DIN/EN 50262													
	M 6	M 8	M 10	M 12	M 16	M 20	M 25	M 32	M 40					
	Ø 6.5	Ø 8.5	Ø 10.5	Ø 12.5	Ø 16.5	Ø 20.5	Ø 25.5	Ø 32.5	Ø 40.5					
18	for metric cable connections / for steel conduit threads. through holes													
	M 6	M 8	M 10	M 12 / PG 7		PG 9	M 16	PG 11	M 20 / PG 13.5		PG 16	M 25	PG 21	M 32
	Ø 6.5	Ø 8.5	Ø 10.5	Ø 12.7		Ø 15.7	Ø 16.2	Ø 18.6	Ø 20.4		Ø 22.5	Ø 25.5	Ø 28.3	Ø 32.5



ULTIMATECUT[®]

Multidrill with Turbo tip

**It is your 5-in-1 tool.
It lets you drill 75% faster.
It gives you ultimate flexibility.**



RUKO Turbo tip

Precise centring = no more centre punching required.
Time saving thanks to faster spot drilling = more holes drilled in the same time.

**RUna
TEC**

RUKO RUnaTEC coating

Thanks to RUKO nano Technology (RUnaTEC), very high cutting speeds can be achieved in addition to low cutting speeds, thus significantly accelerating work processes.

Other positive properties are the extremely high wear resistance and the significant reduction in material welding.

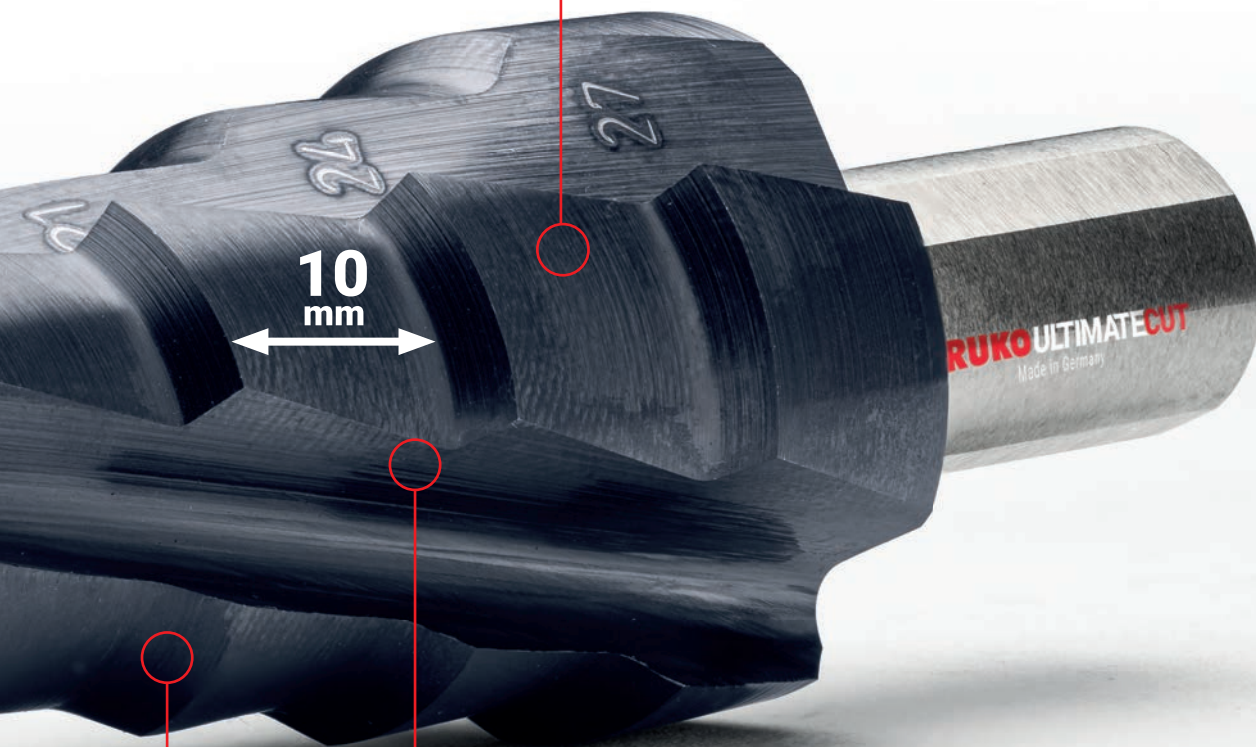

**10
mm**

The all-rounder

Where magnetic drills have problems with low adhesive force, the ULTIMATECUT Multidrill offers ultimate flexibility thanks to its use in hand drills.

It can also reach hard-to-access areas such as T-beams.



RUKO FLOWSTEP® Technology

Controllable on sensitive materials such as thin-walled sheet metal and acrylic glass. Powerful on tough materials such as stainless steel.

The cutting edge geometry enables a smooth, seamless transition between the different diameters.

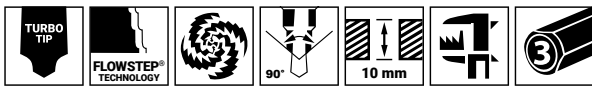

ULTIMATECUT Multidrill HSS RUnaTEC, spiral fluted with turbo tip



The ULTIMATECUT multidrill revolutionizes the work process and sets new standards in machining time with time savings of up to 75%. The step drill from RUKO achieves this through its revolutionary cutting edge geometry by combining the most diverse applications and tools. This means less tools needed, no tool changes and ultimate flexibility.

04



Application tip

- Cooling.
- Adjust speed.
- Low speeds for hand drills.
- Follow table of cutting speeds for ULTIMATECUT step drills.
- Pay attention to total length of drill while drilling.



Packaging: plastic tube

Size no.	Ø1 - Ø2 mm	Drilling range Ø mm	L1 mm	Steps	Ø3 mm	HSS RUnaTEC	
S1	6.0 - 12.0	6.0 7.0 8.0 9.0 10.0 11.0 12.0 mm	105,0	7	8,0	101 082 P	1
M2	6.0 - 20.0	6.0 8.0 10.0 12.0 14.0 16.0 18.0 20.0 mm	120,0	8	10,0	101 083 P	1
L3	6.0 - 27.0	6.0 9.0 12.0 15.0 18.0 21.0 24.0 27.0 mm	125,0	8	12,0	101 084 P	1

		HSS RUnaTEC
3 tfg./pcs.	ULTIMATECUT multidrill set, spiral fluted, sizes S1, M2, L3	101 087 PRO



Table of cutting speeds

Material	Application	Working step	Hand drill	Pillar drill manual feed	Pillar drill / CNC machine automatic feed
	Main application	tapping (drilling through 1st step)	bis 1000 U/min Kühlung empfohlen	up to 1000 rpm cooling recommended	approx. 750 rpm f = 0,1mm/rev cooling necessary
		reaming (from 2nd step)	100-250 U/min Kühlung empfohlen	250- 350 rpm cooling recommended	
	Other application (conditionally suitable)	tapping (drilling through 1st step)	bis 600 U/min Kühlung notwendig	up to 600 rpm cooling necessary	approx. 600 rpm f = 0,05mm/rev cooling necessary
		reaming (from 2nd step)	100-200 U/min Kühlung notwendig	200 - 300 rpm cooling necessary	

