

500 CHISEL RS SDS-PLUS AND SDS-MAX 501 SELF SHARPENING

DRIVE

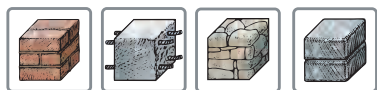

FOR USE IN



PACKAGING



SPECIALTIES

Advantages:

- Permanent sharper chisels
- Reduced wear
- No need to re-sharpen
- Continual high removal performance
- Economical working
- Long tool life
- High stability by means of technical improvements

Characteristics:

- Innovative geometries which make it easy to penetrate into the material to be removed
 - Point chisel with twisted profile
 - Flat chisel with power ribs and bars
 - Spade and scraping chisel with constantly slim surface and strengthening ribs on the sides
- Shot peened and hardened high quality and wear-resistant tool steel

SDS-PLUS / HILTI TE-C



	L1 mm	B mm	EAN 4016707...	12345
Point chisel	250		916434	500 000 250
Flat chisel	250	20	916458	500 120 250
Spade chisel	250	40	916472	500 240 250
Scraping chisel	250	60	916489	500 260 250

SDS-MAX / HILTI TE-Y



	L1 mm	B mm	EAN 4016707...	12345
Point chisel	400		916441	501 000 400
Flat chisel	400	25	916465	501 125 400
Spade chisel	400	80	916496	501 280 400

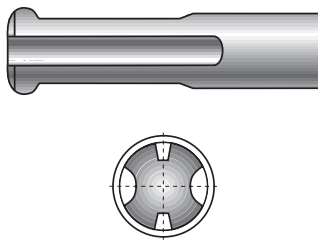

SDS-PLUS / HILTI TE-C

- For use in heavy drill and hammer machines
- For light chiselwork at renovation and restoration

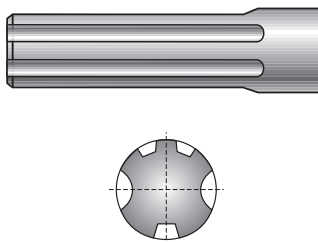

SDS-MAX / HILTI TE-Y

- For use in heavy drill and hammer machines
- Suitable for especially heavy and continuous operation
- For mortising and demolition work, breakthroughs, renovation and restoration