







VRTÁKY A ZÁHLUBNÍKY  
DRILLS  
AND COUNTERSINKS  
BOHRER UND SENKER  
СВЁРЛА И ШЕНКЕРА

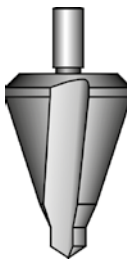

**BUČOVICE**  
**TOOLS a.s.**

# KUŽELOVÉ VRTACÍ TRNY CONICAL PEELING DRILLS SCHÄLAUFBOHRER КОНИЧЕСКИЕ СВЁРЛА

		Velikost/Size/ Grösse/Размер	Velikost/Size/ Grösse/Размер	Velikost/Size/ Grösse/Размер	Velikost/Size/ Grösse/Размер	Velikost/Size/ Grösse/Размер		
		<b>3/7 bit</b>	<b>3/22 (č. 2A)</b>	<b>9/22</b>	<b>16/30 (č. 3)</b>	<b>40/60 (č. 6)</b>		
		<b>3/14 (č. 1)</b>	<b>6/20 (č. 2)</b>	<b>4/30</b>	<b>36/50 (č. 5)</b>			
		<b>1/7,8</b>		<b>6/30 (č. L)</b>	<b>26/40 (č. 4)</b>			
		<b>2/10,2</b>		<b>8/30</b>				
								
		HSS/HSSE	HSS/HSSE	HSS/HSSE	HSS/HSSE	HSS/HSSE		
		n/min	n/min	n/min	n/min	n/min		
<b>P</b>	1	600 - 300	400 - 200	300 - 100	100 - 50	60 - 30	0,3 - 4 mm	○
	2	600 - 200	400 - 150	300 - 90	90 - 40	50 - 25	0,3 - 2 mm	○
	3	600 - 300	400 - 200	300 - 100	100 - 50	60 - 30	0,3 - 4 mm	○
	4	400 - 200	300 - 100	200 - 70	60 - 30	40 - 20	0,3 - 2 mm	○
	5							
	6	400 - 200	300 - 100	200 - 70	60 - 30	40 - 20	0,3 - 2 mm	○
	7	400 - 200	300 - 100	200 - 70	60 - 30	40 - 20	0,3 - 2 mm	○
<b>M</b>	1							
	2							
<b>K</b>	1	400 - 200	300 - 100	200 - 70	60 - 30	40 - 20	0,3 - 2 mm	○
	2	400 - 200	300 - 100	200 - 70	60 - 30	40 - 20	0,3 - 2 mm	○
	3	400 - 200	300 - 100	200 - 70	60 - 30	40 - 20	0,3 - 2 mm	○
<b>N</b>	1	400 - 200	300 - 100	200 - 70	60 - 30	40 - 20	0,3 - 2 mm	○
	2	400 - 200	300 - 100	200 - 70	60 - 30	40 - 20	0,3 - 2 mm	○
	3	1200 - 700	900 - 500	600 - 300	150 - 80	100 - 50	0,3 - 6 mm	○
	4	1200 - 700	900 - 500	600 - 300	150 - 80	100 - 50	0,3 - 6 mm	○
	5	1200 - 700	900 - 500	600 - 300	150 - 80	100 - 50	0,3 - 6 mm	○
	6	1200 - 700	900 - 500	600 - 300	150 - 80	100 - 50	0,3 - 6 mm	○
	7	1500 - 700	1000 - 700	900 - 500	250 - 120	150 - 80	<10 mm	V/O
	8	1500 - 700	1000 - 700	900 - 500	250 - 120	150 - 80	<10 mm	V/O
<b>S</b>								
<b>H</b>	1							
	2							
	3							

○ Omezené použití / Possible use / Geeignet / Ограниченно  
● Doporučené použití / Optimal use / Optimal / Оптимально

**HSS**  
code 541 XXX

**HSSE**  
code 544 XXX

**HSS TiN**  
code 546 XXX

**HSSE TiN**  
code 596 XXX

**Kuželové vrtací trny**  
**Conical peeling drills**  
**Schälbohrer**  
**Конические свёрла**

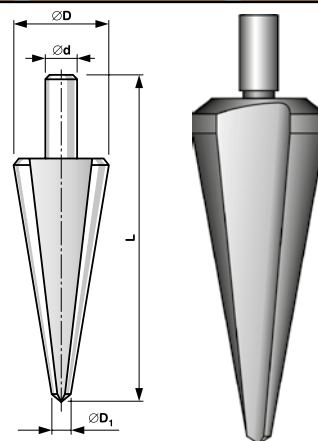

Velikost/Size/Größe/Размер

D<sub>1</sub>

D

Ø d

L

code HSS

code HSSE

3/14 (č. 1)

3,5

14

6

58

541 140

544 140

6/20 (č. 2)

6

20

8

66

541 200

544 200

3/22 (č. 2A)

3,5

22,5

8

72

541 225

544 225

9/22

9,5

22,5

10

66

541 230

544 230

4/30

4

30

10

103

541 250

544 250

6/30 (L)

6

30

10

103

541 300

544 300

8/30

8

30

10

97

541 260

544 260

Velikost/Size/Größe/Размер

D<sub>1</sub>

D

Ø d

L

code HSS TiN

code HSSE TiN

3/14 (č. 1)

3,5

14

6

58

546 140 TiN

596 140 TiN

6/20 (č. 2)

6

20

8

66

546 200 TiN

596 200 TiN

3/22 (č. 2A)

3,5

22,5

8

72

546 225 TiN

596 225 TiN

9/22

9,5

22,5

10

66

546 230 TiN

596 230 TiN

4/30

4

30

10

103

546 250 TiN

596 250 TiN

6/30 (L)

6

30

10

103

546 300 TiN

596 300 TiN

8/30

8

30

10

97

546 260 TiN

596 260 TiN



**BUČOVICE**  
**TOOLS a.s.**

Materiál: HSS; HSSE

Material: HSS; HSSE

Werkstoff: HSS; HSSE

Mamepuan: HSS; HSSE

**HSS**  
code 542 XXX

**HSSE**  
code 545 XXX

**HSS TiN**  
code 547 XXX

**HSSE TiN**  
code 597 XXX

**Kuželové vrtací trny**  
**Conical peeling drills**  
**Schälbohrer**  
**Конические свёрла**

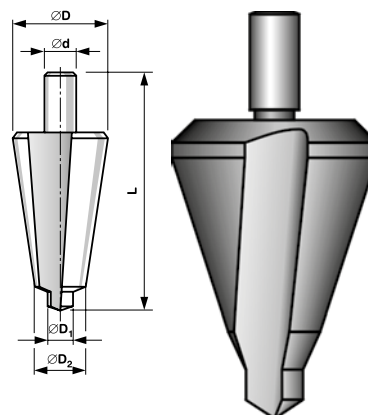

Velikost/Size/Größe/Размер	D <sub>2</sub>	D	Ø D <sub>1</sub>	Ø d	L	code HSS	code HSSE
16/30 (č. 3)	16	30	10	10	75	542 300	545 300
26/40 (č. 4)	26	40	10	12	85	542 400	545 400
36/50 (č. 5)	36	50	14	13	87	542 500	545 500
40/60 (č. 6)	40	61	16	13	100	542 600	545 600

Velikost/Size/Größe/Размер	D <sub>2</sub>	D	Ø D <sub>1</sub>	Ø d	L	code HSS TiN	code HSSE TiN
16/30 (č. 3)	16	30	10	10	75	547 300 TiN	597 300 TiN
26/40 (č. 4)	26	40	10	12	85	547 400 TiN	597 400 TiN
36/50 (č. 5)	36	50	14	13	87	547 500 TiN	597 500 TiN
40/60 (č. 6)	40	61	16	13	100	547 600 TiN	597 600 TiN

Materiál: HSS; HSSE

Material: HSS; HSSE

Werkstoff: HSS; HSSE

Mamepuan: HSS; HSSE

**HSS**  
code 543 XXX

**HSSE**  
code 593 XXX

**Kuželové vrtací trny**  
**Conical peeling drills**  
**Schälbohrer**  
**Конические свёрла**

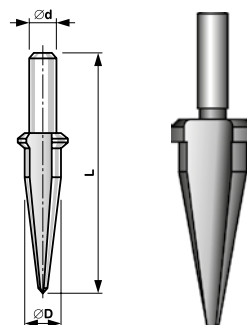

Velikost/Size/Größe/Размер	Ø D	Ø d	L	code HSS	code HSSE
1/7,8	7,8	6	49	543 078	593 078
2/10,2	10,2	6	53	543 102	593 102

Materiál: HSS; HSSE

Material: HSS; HSSE

Werkstoff: HSS; HSSE

Mamepuan: HSS; HSSE

**BUČOVICE**  
szteco **TOOLS a.s.**

**HSS**  
code 540 XXX

**Kuželové vrtací trny**  
- bit  
**Conical peeling drills**  
- bits  
**Schälbohrer - Bits**  
**Конические свёрла**  
- БИТЫ

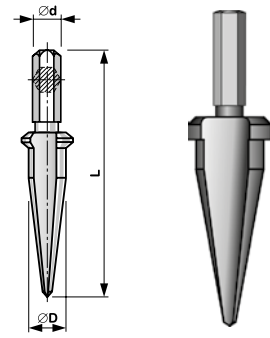

Velikost/Size/Größe/Размер	Ø D	Ø d	L	code
3/7	3-7	1/4"	40	540 070
3/14	3-14	1/4"	58	540 140





Materiál: HSS

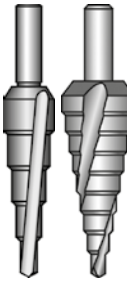
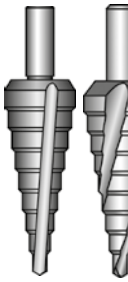

Material: HSS

Werkstoff: HSS

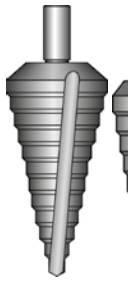
Mamepuan: HSS

# STUPŇOVITÉ VRTÁKY STEPPED PEELING DRILLS STUFENBOHRER СТУПЕНЧАТЫЕ СВЁРЛА

		Velikost/Size/ Grösse/Размер	Velikost/Size/ Grösse/Размер	Velikost/Size/ Grösse/Размер	Velikost/Size/ Grösse/Размер		
		<b>4/12-1 (č.0/9)</b>	<b>10/20</b>	<b>4/30</b>	<b>6/38 (č.3)</b>		
		<b>4/12-2 (č.0/5)</b>	<b>6/24</b>	<b>6/30</b>	<b>PG4</b>		
			<b>4/20 (č.1)</b>	<b>20/30</b>	<b>PG3</b>		
				<b>6/30 (č.2)</b>	<b>5/35</b>		
				<b>PG1</b>			
				<b>PG2</b>			
							
		HSS/HSSE	HSS/HSSE	HSS/HSSE	HSS/HSSE		
		n/min	n/min	n/min	n/min		
<b>P</b>	1	700 - 300	600 - 200	600 - 150	600 - 130	0,3 - 4 mm	0
	2	700 - 200	600 - 150	500 - 100	600 - 90	0,3 - 4 mm	0
	3	700 - 300	600 - 200	600 - 150	600 - 130	0,3 - 4 mm	0
	4	600 - 200	600 - 150	500 - 100	500 - 90	0,3 - 4 mm	0
	5						
	6	600 - 200	500 - 150	500 - 100	500 - 90	0,3 - 4 mm	0
	7	600 - 200	500 - 150	500 - 100	500 - 90	0,3 - 4 mm	0
<b>M</b>	1						
	2						
<b>K</b>	1	600 - 200	600 - 150	500 - 100	500 - 90	0,3 - 4 mm	0
	2	600 - 200	500 - 150	500 - 100	500 - 90	0,3 - 4 mm	0
	3	600 - 200	500 - 150	500 - 100	500 - 90	0,3 - 4 mm	0
<b>N</b>	1	600 - 200	500 - 150	500 - 100	500 - 90	0,3 - 4 mm	0
	2	600 - 200	500 - 150	500 - 100	500 - 90	0,3 - 4 mm	0
	3	1300 - 600	1200 - 500	1200 - 400	1200 - 300	0,3 - 6 mm	0
	4	1300 - 600	1200 - 500	1200 - 400	1200 - 300	0,3 - 6 mm	0
	5	1300 - 600	1200 - 500	1200 - 400	1200 - 300	0,3 - 6 mm	0
	6	1300 - 600	1200 - 500	1200 - 400	1200 - 300	0,3 - 6 mm	0
	7	800 - 300	700 - 250	700 - 200	700 - 150	<10 mm	V/O
	8	800 - 300	700 - 250	700 - 200	700 - 150	<10 mm	V/O
<b>S</b>							
<b>H</b>	1						
	2						
	3						

 Omezené použití / Possible use / Geeignet / Ограниченно  
 Doporučené použití / Optimal use / Optimal / Оптимально

 **BUČOVICE**  
TOOLS a.s.

**HSS**  
code 641 XXX

**HSSE**  
code 691 XXX

**HSS TiN**  
code 646 XXX

**HSSE TiN**  
code 696 XXX

**Stupňovité vrtáky**  
**Stepped peeling drills**  
**Stufenbohrer**  
**Ступенчатые свёрла**

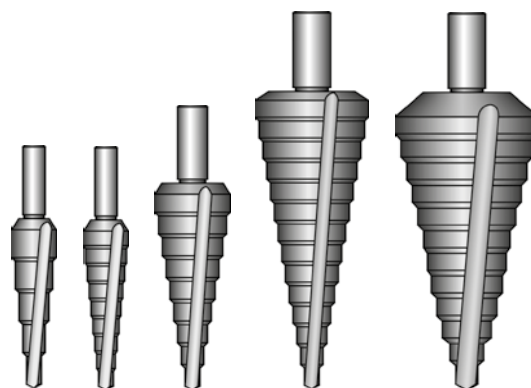
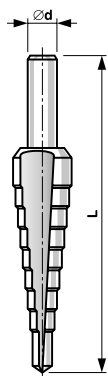

Velikost/Size/Größe/Размер	Ø D	Ø d	L	code HSS	code HSSE
4/12-2 (č. 0/5)	4; 6; 8; 10; 12	6	65	641 005	691 005
4/12-1 (č. 0/9)	4; 5; 6; 7; 8; 9; 10; 11; 12	6	65	641 009	691 009
4/20 (č. 1)	4; 6; 8; 10; 12; 14; 16; 18; 20	8	75	641 010	691 010
10/20	10; 11; 12; 13; 14; 15; 16; 17; 18; 19; 20	10	82	641 027	691 027
6/24	6; 8; 10; 12; 14; 16; 18; 20; 22; 24	10	85	641 013	691 013
4/30	4; 6; 8; 10; 12; 14; 16; 18; 20; 22; 24; 26; 28; 30	13	100	641 015	691 015
6/30 (č. 2)	6; 8; 10; 12; 14; 16; 18; 20; 22; 24; 26; 28; 30	10	100	641 020	691 020
20/30	20; 21; 22; 23; 24; 25; 26; 27; 28; 29; 30	13	88	641 031	691 031
5/35	5; 7,5; 10; 13; 16; 19; 21; 23; 26; 29; 31; 33; 35	13	100	641 025	691 025
6/38 (č. 3)	6; 9; 13; 16; 19; 21; 23; 26; 29; 32; 35; 38	10	100	641 030	691 030

Velikost/Size/Größe/Размер	Ø D	Ø d	L	code HSS TiN	code HSSE TiN
4/12-2 TiN (č. 0/5)	4; 6; 8; 10; 12	6	65	646 005 TiN	696 005 TiN
4/12-1 TiN (č. 0/9)	4; 5; 6; 7; 8; 9; 10; 11; 12	6	65	646 009 TiN	696 009 TiN
4/20 TiN (č. 1)	4; 6; 8; 10; 12; 14; 16; 18; 20	8	75	646 010 TiN	696 010 TiN
10/20 TiN	10; 11; 12; 13; 14; 15; 16; 17; 18; 19; 20	10	82	646 027 TiN	696 027 TiN
6/24 TiN	6; 8; 10; 12; 14; 16; 18; 20; 22; 24	10	85	646 013 TiN	696 013 TiN
4/30 TiN	4; 6; 8; 10; 12; 14; 16; 18; 20; 22; 24; 26; 28; 30	13	100	646 015 TiN	696 015 TiN
6/30 TiN (č. 2)	6; 8; 10; 12; 14; 16; 18; 20; 22; 24; 26; 28; 30	10	100	646 020 TiN	696 020 TiN
20/30 TiN	20; 21; 22; 23; 24; 25; 26; 27; 28; 29; 30	13	88	646 031 TiN	696 031 TiN
5/35 TiN	5; 7,5; 10; 13; 16; 19; 21; 23; 26; 29; 31; 33; 35	13	100	646 025 TiN	696 025 TiN
6/38 TiN (č. 3)	6; 9; 13; 16; 19; 21; 23; 26; 29; 32; 35; 38	10	100	646 030 TiN	696 030 TiN



**BUČOVICE**  
**TOOLS a.s.**

Materiál: HSS; HSSE

Material: HSS; HSSE

Werkstoff: HSS; HSSE

Mamepuan: HSS; HSSE

**HSS**  
code 642 XXX

**HSSE**  
code 692 XXX

**Stupňovité vrtáky PG**  
**Stepped peeling drills PG**  
**Stufenbohrer PG**  
**Ступенчатые свёрла PG**

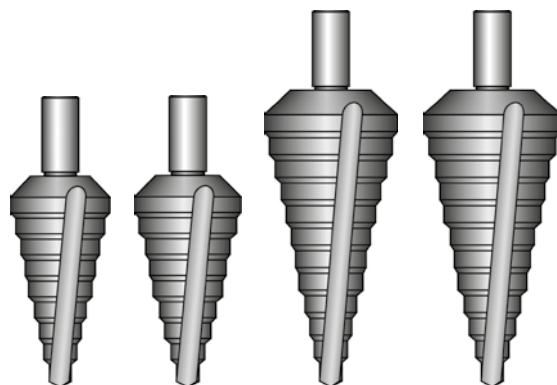
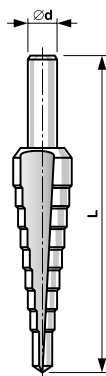

Velikost/Size/Größe/Размер	Ø D	Ø d	L	code HSS	code HSSE
PG 1	6; 9; 11,4; 14; 17,25; 19; 21,25; 26,75	10	77	642 010	692 010
PG 2	6; 9; 12,5; 15,2; 18,6; 20,4; 22,5; 28,3	10	77	642 020	692 020
PG 3	6; 9; 11,4; 14; 17,25; 19; 21,25; 24; 26,75; 30; 33; 35,7	10	100	642 030	692 030
PG 4	6; 9; 12,5; 15,2; 18,6; 20,4; 22,5; 26; 28,3; 30,5; 34; 37	10	100	642 040	692 040

Materiál: HSS; HSSE

Material: HSS; HSSE

Werkstoff: HSS; HSSE

Mamepuan: HSS; HSSE

**HSS**  
code 643 XXX

**Stupňovité vrtáky - bit**  
**Stepped peeling drills - bits**  
**Stufenbohrer - Bits**  
**Ступенчатые свёрла - БИТЫ**

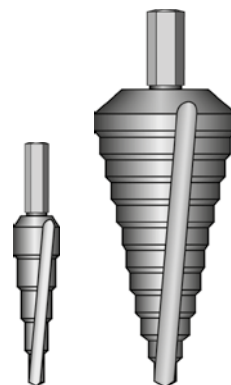
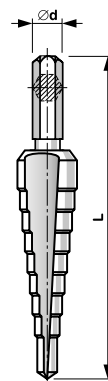

Velikost/Size/Größe/Размер	Ø D	Ø d	L	code
4/12	4; 6; 8; 10; 12	1/4"	54	643 012
4/20	4; 6; 8; 10; 12; 14; 16; 18; 20	1/4"	54	643 010
5/13	5; 7; 9; 11; 13	1/4"	54	643 013
8/20	8; 10; 12; 14; 16; 18; 20	1/4"	67	643 020
9/21	9; 11; 13; 15; 17; 19; 21	1/4"	67	643 021
6/30	6; 8; 10; 12; 14; 16; 18; 20; 22; 24; 26; 28; 30	1/4"	67	643 025

Materiál: HSS

Material: HSS

Werkstoff: HSS

Mamepuan: HSS

 **BUČOVICE**  
**TOOLS a.s.**

**HSS**  
code 648 XXX

**HSSE**  
code 698 XXX

**HSS TiN**  
code 649 XXX

**HSSE TiN**  
code 699 XXX

Stupňovité vrtáky  
se šroubovitou drážkou  
Stepped peeling drills -  
spiral flute  
Stufenbohrer -  
Rechtsspiralnute  
Ступенчатые свёрла -  
винтовая дорожка

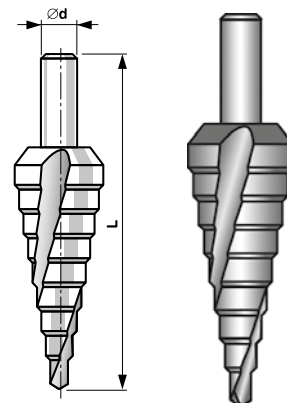

Velikost/Size/Größe/Размер	Ø D	Ø d	L	code HSS	code HSSE	code HSS TiN	code HSSE TiN
4/12-1 (č. 0/9)	4, 5, 6, 7, 8, 9, 10, 11, 12	6	65	648 009	698 009	649 009 TiN	699 009 TiN
4/20 (č. 1)	4, 6, 8, 10, 12, 14, 16, 18, 20	8	75	648 010	698 010	649 010 TiN	699 010 TiN
6/30 (č. 2)	6, 8, 10, 12, 14, 16, 18, 20, 22, 24, 26, 28, 30	10	100	648 020	698 020	649 020 TiN	699 020 TiN
6/38 (č. 3)	6, 9, 13, 16, 19, 21, 23, 26, 29, 32, 35, 38	10	100	648 030	698 030	649 030 TiN	699 030 TiN

Materiál: HSS; HSSE

Material: HSS; HSSE

Werkstoff: HSS; HSSE

Mamepuan: HSS; HSSE

**HSS**  
code 645 XXX

**HSSE**  
code 695 XXX

Stupňovité vrtáky  
se šroubovitou drážkou  
Stepped peeling drills  
PG - spiral flute  
Stufenbohrer PG -  
Rechtsspiralnute  
Ступенчатые свёрла PG  
- винтовая дорожка

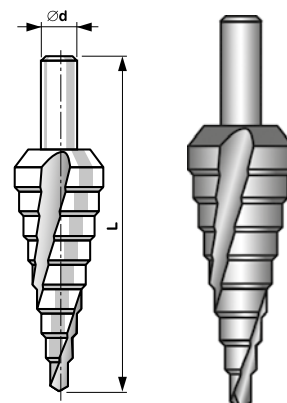

Velikost/Size/Größe/Размер	Ø D	Ø d	L	code HSS	code HSSE
PG 1	6; 9; 11,4; 14; 17,25; 19; 21,25; 26,75	10	77	645 010	695 010
PG 2	6; 9; 12,5; 15,2; 18,6; 20,4; 22,5; 28,3	10	77	645 020	695 020
PG 3	6; 9; 11,4; 14; 17,25; 19; 21,25; 26,75; 30; 33; 35,7	10	100	645 030	695 030
PG 4	6; 9; 12,5; 15,2; 18,6; 20,4; 22,5; 28,3; 30,5; 34; 37	10	100	645 040	695 040

**HSS**  
code 541 XXX







**HSSE**  
code 544 XXX

**HSS TiN**  
code 546 XXX

**HSSE TiN**  
code 596 XXX

Sady kuželových  
vrtacích trnů  
Conical peeling  
drills set  
Schälbohrer-Satz  
Набор  
конических свёрл



Norma / Standard / Norm / Norma	kg	axbxc	code	Norma / Standard / Norm / Norma	kg	axbxc	code
Typ - K 1 HSS Typ - K 1 HSSE 	3,5/14; 6/20; 16/30 0,22 0,22	73x17x133 73x17x133	541 801 544 801	Typ - K 1 HSSTiN Typ - K 1 HSSETiN 	3,5/14; 6/20; 16/30 0,22 0,22	73x17x133 73x17x133	546 801 TiN 596 801 TiN
Typ - K 2 HSS Typ - K 2 HSSE 	3,5/14; 16/30 0,17 0,17	73x17x133 73x17x133	541 802 544 802	Typ - K 2 HSSTiN Typ - K 2 HSSETiN 	3,5/14; 16/30 0,17 0,17	73x17x133 73x17x133	546 802 TiN 596 802 TiN
Typ - K 3 HSS Typ - K 3 HSSE 	6/20; 16/30 0,20 0,20	73x17x133 73x17x133	541 803 544 803	Typ - K 3 HSSTiN Typ - K 3 HSSETiN 	6/20; 16/30 0,20 0,20	73x17x133 73x17x133	546 803 TiN 596 803 TiN

**HSS**  
code 541 XXX





**HSSE**  
code 544 XXX

**HSS TiN**  
code 546 XXX

**HSSE TiN**  
code 596 XXX

Sady kuželových  
vrtacích trnů  
Conical peeling  
drills set  
Schälbohrer-Satz  
Набор  
конических свёрл



Norma / Standard / Norm / Norma	kg	axbxc	code
Typ - K 4 HSS 	3/14; 6/20; 16/30 0,56	110x135x45	541 804
Typ - K 4 HSSTiN 	3/14; 6/20; 16/30 0,56	110x135x45	546 804 TiN
Typ - K 4 HSSE 	3/14; 6/20; 16/30 0,56	110x135x45	544 804
Typ - K 4 HSSETiN 	3/14; 6/20; 16/30 0,56	110x135x45	596 804 TiN

**HSS**  
code 641 XXX







**HSSE**  
code 691 XXX

**HSS TiN**  
code 646 XXX

**HSSE TiN**  
code 696 XXX

**Sady  
stupňovitých vrtáků  
Stepped peeling  
drills set  
Stufenbohrer-Satz  
Набор конических  
ступенчатых свёрл**



Norma / Standard / Norm / Norma	kg	axbxc	code	Norma / Standard / Norm / Norma	kg	axbxc	code
Typ - S 1 HSS Typ - S 1 HSSE 	4/12-1; 4/20 0,11 0,11	73x17x133 73x17x133	641 801 691 801	Typ - S 1 HSSTiN Typ - S 1 HSSETiN 	4/12-1; 4/20 0,11 0,11	73x17x133 73x17x133	646 801 TiN 696 801 TiN
Typ - S 2 HSS Typ - S 2 HSSE 	4/12-1; 6/30 0,26 0,26	73x17x133 73x17x133	641 802 691 802	Typ - S 2 HSSTiN Typ - S 2 HSSETiN 	4/12-1; 6/30 0,26 0,26	73x17x133 73x17x133	646 802 TiN 696 802 TiN
Typ - S 3 HSS Typ - S 3 HSSE 	6/30; 6/38 0,46 0,46	73x17x133 73x17x133	641 803 691 803	Typ - S 3 HSSTiN Typ - S 3 HSSETiN 	6/30; 6/38 0,46 0,46	73x17x133 73x17x133	646 803 TiN 696 803 TiN

**HSS**  
code 641 XXX





**HSSE**  
code 691 XXX

**HSS TiN**  
code 646 XXX

**HSSE TiN**  
code 696 XXX

**Sady  
stupňovitých vrtáků  
Stepped peeling  
drills set  
Stufenbohrer-Satz  
Набор конических  
ступенчатых свёрл**



Norma / Standard / Norm / Norma	kg	axbxc	code
Typ - S 4 HSS 	4/12-1; 10/20; 20/30 0,560	110x135x45	641 804
Typ - S 4 HSSTiN 	4/12-1; 10/20; 20/30 0,560	110x135x45	646 804 TiN
Typ - S 4 HSSE 	4/12-1; 10/20; 20/30 0,560	110x135x45	691 804
Typ - S 4 HSSETiN 	4/12-1; 10/20; 20/30 0,560	110x135x45	696 804 TiN

Materiál: HSS; HSSE

Material: HSS; HSSE

Werkstoff: HSS; HSSE

Mamepuan: HSS; HSSE

 **BUČOVICE  
TOOLS a.s.**

**HSS**  
code 641 XXX

**HSSE**  
code 691 XXX

**HSS TiN**  
code 646 XXX

**HSSE TiN**  
code 696 XXX

**Sady  
stupňovitých vrtáků  
Stepped peeling  
drills set  
Stufenbohrer-Satz  
Набор конических  
ступенчатых свёрл**



Norma / Standard / Norm / Norma

Typ - S 5 HSS 4/12-1; 4/20/ 6/30  
Typ - S 5 HSSE



kg

axbxc

code

0,6

110x150x35

641 805

0,6

110x150x35

691 805

Typ - S 5 HSS TiN 4/12-1; 4/20/ 6/30  
Typ - S 5 HSSE TiN



0,6

110x150x35

646 805

0,6

110x150x35

696 805

**HSS**  
code 648 XXX

**HSSE**  
code 698 XXX

**HSSE TiN**  
code 699 XXX

**Sady  
stupňovitých vrtáků  
Stepped peeling  
drills set  
Stufenbohrer-Satz  
Набор конических  
ступенчатых свёрл**



Norma / Standard / Norm / Norma

Typ - S 6 HSS 4/12-1; 4/20/ 6/30  
Typ - S 6 HSSE



kg

axbxc

code

0,6

110x150x35

648 805

0,6

110x150x35

698 805

Typ - S 6 HSSE TiN 4/12-1; 4/20/ 6/30



0,6

110x150x35

699 805



**BUČOVICE  
TOOLS a.s.**

Materiál: HSS; HSSE

Material: HSS; HSSE

Werkstoff: HSS; HSSE

Mamepuan: HSS; HSSE