

**KUŽELOVÉ A ODJEHLOVACÍ ZÁHLUBNÍKY**  
**COUNTERSINKS AND DEBURRER COUNTERSINKS**  
**KEGELSENKER UND ENTGRATUNSENKER**  
**КОНИЧЕСКИЕ ШЕНКЕРА И ШЕНКЕРА**  
**ДЛЯ ОЧИСТКИ ОТВЕРСТИЙ ОТ СТРУЖКИ**

		Velikost/Size/ Größe/Размер	Velikost/Size/ Größe/Размер	Velikost/Size/ Größe/Размер	Velikost/Size/ Größe/Размер	Velikost/Size/ Größe/Размер	Velikost/Size/ Größe/Размер		
		4,3 - 7,3	8 - 12,4	13 - 16,5	19 - 23	25 - 31	34 - 40	41 - 50	
		2/5	5/10	10/15	15/20	25/30	34 - 40	41 - 50	
		20/25							
		HSS/HSSE	HSS/HSSE	HSS/HSSE	HSS/HSSE	HSS/HSSE	HSS/HSSE	HSS/HSSE	
		n/min	n/min	n/min	n/min	n/min	n/min	n/min	
<b>P</b>	1	700	400	250	150	120	90	80	0
	2	600	350	200	120	90	70	60	0
	3	700	400	250	150	120	90	80	0
	4	400	250	150	90	70	50	40	0
	5								
	6	400	250	150	90	70	50	40	0
	7	400	250	150	90	70	50	40	0
<b>M</b>	1								
	2								
<b>K</b>	1								
	2								
	3								
<b>N</b>	1	900	500	350	200	150	100	80	0
	2	900	500	350	200	150	100	80	0
	3	900	500	350	200	150	100	80	0
	4	900	500	350	200	150	100	80	0
	5	900	500	350	200	150	100	80	0
	6	900	500	350	200	150	100	80	0
	7	600	350	300	150	120	90	80	V/E
	8	400	250	200	100	90	70	60	V/E
<b>S</b>									
<b>H</b>	1								
	2								
	3								

Omezené použití / Possible use / Geeignet / Ограниченно  
 Doporučené použití / Optimal use / Optimal / Оптимально

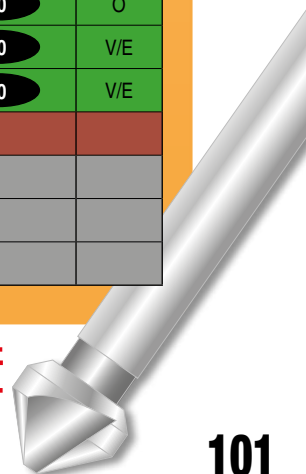

**HSS**  
code 743 XXX

**Kuželové záhlubníky  
jednobřité 90°  
Countersinks 90°  
Kegelsenker 90°  
Конические шенкера 90°**

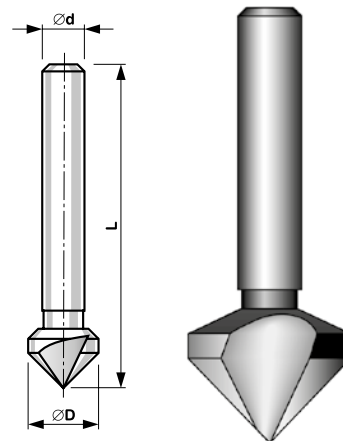

Ø D	Ø d	L	code
5	4	40	743 050
6	5	45	743 060
8	6	46	743 080
10	6	46	743 100
12	8	46	743 120
16	8	46,5	743 160
20	10	47	743 200
25	10	51	743 250
30	12	71	743 300

Materiál: HSS

Material: HSS

Werkstoff: HSS

Mamepuan: HSS

**HSS**  
code 741 XXX

**HSSE**  
code 745 XXX

**HSS TiN**  
code 751 XXX

**HSSE TiN**  
code 795 XXX

**Kuželové záhlubníky  
třibřité 90°  
Countersinks 90°  
Kegelsenker 90°  
Конические шенкера 90°**

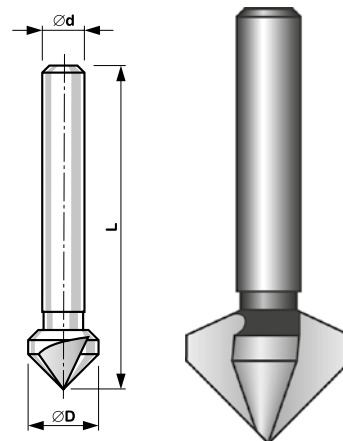

Ø D	Ø d	L	code <sup>x)</sup>	Ø D	Ø d	L	code <sup>x)</sup>
4,3	4	40	XXX 043	16	8	46,5	XXX 160
5	4	40	XXX 050	16,5	10	60	XXX 165
6	5	45	XXX 060	19	10	63	XXX 190
6,3	5	46	XXX 063	20	10	47	XXX 200
7	6	50	XXX 070	20,5	10	63	XXX 205
8	6	46	XXX 080	23	10	67	XXX 230
8,3	6	46	XXX 083	25	10	51	XXX 250
10	6	46	XXX 100	25,5	10	66	XXX 255
10,4	6	54	XXX 104	30	12	71	XXX 300
11,5	8	56	XXX 115	31	12	71	XXX 310
12	8	46	XXX 120	40	13	80	XXX 400
12,4	8	54	XXX 124	50	13	85	XXX 500
14,4	8	56	XXX 144				

- x) 741 XXX - HSS
- x) 745 XXX - HSSE
- x) 751 XXX - HSS TiN
- x) 795 XXX - HSSE TiN



**BUČOVICE  
TOOLS a.s.**

Materiál: HSS; HSSE

Material: HSS; HSSE

Werkstoff: HSS; HSSE

Mamepuan: HSS; HSSE

# DIN 335 C

**HSS**  
code 746 XXX

**HSSE**  
code 796 XXX

**HSS TiN**  
code 747 XXX

**HSSE TiN**  
code 797 XXX

**HSSE VA**  
code 798 XXX

**Kuželové záhlubníky 90°**  
**Countersinks 90°**  
**Kegelsenker 90°**  
**Конические шенкера 90°**

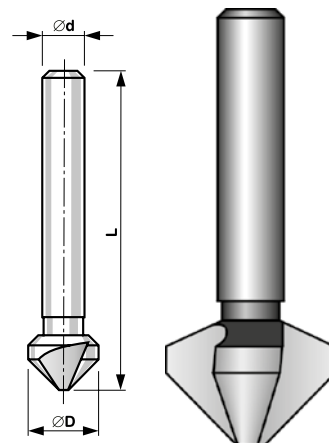

Ø D	Ø d	L	code <sup>x)</sup>	Ø D	Ø d	L	code <sup>x)</sup>
4,3	4	40	XXX 043	11,5	8	56	XXX 115
5	4	40	XXX 050	12,4	8	56	XXX 124
5,3	4	40	XXX 053	13,4	8	56	XXX 134
5,8	5	45	XXX 058	15	10	60	XXX 150
6	5	45	XXX 060	16,5	10	60	XXX 165
6,3	5	45	XXX 063	19	10	63	XXX 190
7	6	50	XXX 070	20,5	10	63	XXX 205
7,3	6	50	XXX 073	23	10	67	XXX 230
8	6	50	XXX 080	25	10	68	XXX 250
8,3	6	50	XXX 083	26	10	68	XXX 260
9,4	6	50	XXX 094	28	12	71	XXX 280
10	6	50	XXX 100	30	12	71	XXX 300
10,4	6	50	XXX 104	31	12	71	XXX 310

- x) 746 XXX - HSS
- x) 796 XXX - HSSE
- x) 747 XXX - HSS TiN
- x) 797 XXX - HSSE TiN
- x) 798 XXX - HSSE VA

Materiál: HSS; HSSE

Material: HSS; HSSE

Werkstoff: HSS; HSSE

Mamepuan: HSS; HSSE

# DIN 335 D

**HSS**  
code 735 XXX

**Kuželové záhlubníky 90° s kuželovou stopkou**  
**Countersinks 90° with taper shank**  
**Kegelsenker 90° mit Kegelschaft**  
**Конические шенкера 90° с коническим хвостовиком**

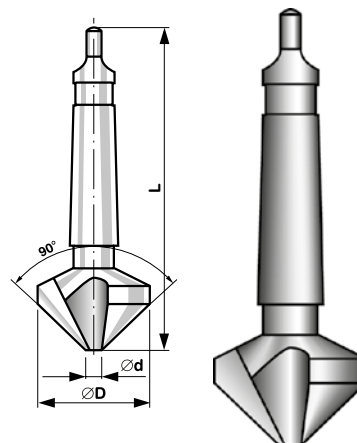

Ø D	Ø d	L	MORSE	code HSS	Ø D	Ø d	L	MORSE	code
15	3,2	85	1	735 150	30	4,2	112	2	735 300
16,5	3,2	85	1	735 165	31	4,2	112	2	735 310
19	3,5	100	2	735 190	34	4,5	118	2	735 340
20,5	3,5	100	2	735 205	37	4,8	118	2	735 370
23	3,8	106	2	735 230	40	10,0	140	3	735 400
25	3,8	106	2	735 250	50	14,0	150	3	735 500
26	3,8	106	2	735 260	63	16,0	180	4	735 630
28	4,0	112	2	735 280					

Materiál: HSS

Material: HSS;

Werkstoff: HSS

Mamepuan: HSS

**BUČOVICE**  
TOOLS a.s.

**HSS**  
code 744 XXX

**Kuželové záhlubníky 90°  
tříbřité - bit**  
**Countersinks 90°3 flutes  
- bits**  
**Kegelsenker 90°  
3 Schneiden - Bits**  
**Конические шенкера 90°  
- БИТЫ**

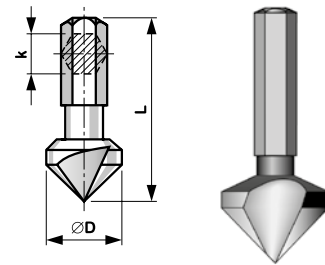

Ø D	L	k	code
6,3	31	1/4"	744 063
8,3	31	1/4"	744 083
10,4	34	1/4"	744 104
12,4	35	1/4"	744 124
16,5	40	1/4"	744 165
20,5	41	1/4"	744 205

**HSS**  
code 844 XXX

**Kuželové záhlubníky 90°  
tříbřité - bit**  
**Countersinks 90°3 flutes  
- bits**  
**Kegelsenker 90°  
3 Schneiden - Bits**  
**Конические шенкера 90°  
- БИТЫ**

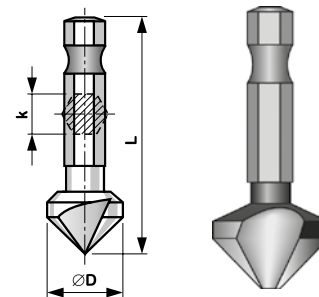

Ø D	L	k	code
6,3	37	1/4"	844 063
8,3	39	1/4"	844 083
10,4	40	1/4"	844 104
12,4	42	1/4"	844 124
16,5	45	1/4"	844 165
20,5	49	1/4"	844 205



**BUČOVICE  
TOOLS a.s.**

Materiál: HSS

Material: HSS

Werkstoff: HSS

Mamepuan: HSS

# DIN 335 C XL

**HSSE**  
code 799 XXX

**Kuželové záhlubníky 90°  
tříbřité**  
**Countersinks 90° 3 flutes**  
**Kegelsenker 90°**  
**3 Schneiden**  
**Конические шенкера 90°**

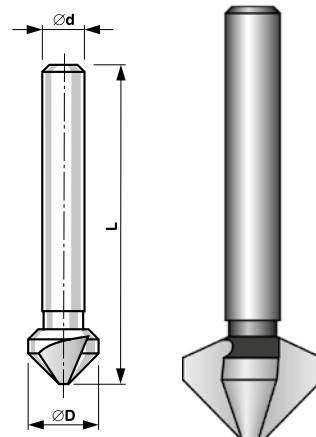

Ø D	Ø d	L	code HSSE
6,3	5	106	799 063
8,3	6	107	799 083
10,4	6	109	799 104
12,4	8	109	799 124
16,5	10	112	799 165
20,5	10	116	799 205
25	10	119	799 250

Materiál: HSSE

Material: HSSE

Werkstoff: HSSE

Mamepuan: HSSE

**HSS**  
code 830 XXX

**HSSE**  
code 890 XXX

**Kuželové záhlubníky 120°  
tříbřité**  
**Countersinks 120° 3 flutes**  
**Kegelsenker 120°**  
**3 Schneiden**  
**Конические шенкера 120°**

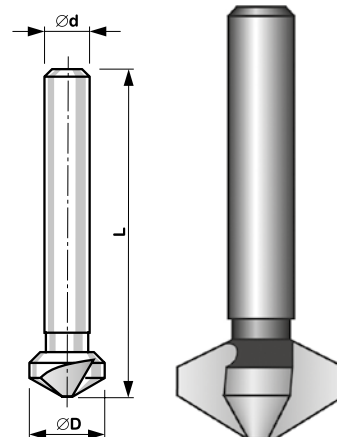

Ø D	Ø d	L	code HSS	code HSSE
6,3	5	44	830 063	890 063
8,3	6	49	830 083	890 083
10,4	6	50	830 104	890 104
12,4	8	53	830 124	890 124
16,5	10	56	830 165	890 165
20,5	10	59	830 205	890 205
25	10	61	830 250	890 250

Materiál: HSS; HSSE

Material: HSS; HSSE

Werkstoff: HSS; HSSE

Mamepuan: HSS; HSSE

**BUČOVICE**  
TOOLS a.s.

# DIN 334 C

**HSS**  
code 846 XXX

**HSSE**  
code 896 XXX

Kuželové záhlubníky 60°  
tříbřité  
Countersinks 60° 3 flutes  
Kegelsenker 60°  
3 Schneiden  
Конические шенкера 60°

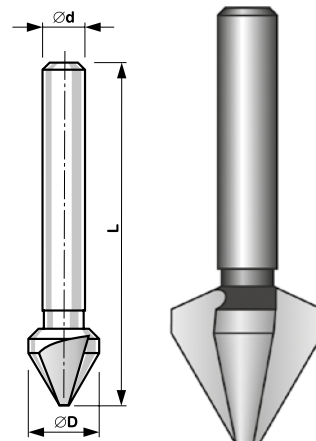

Ø D	Ø d	L	code HSS	code HSSE
6,3	5	45	846 063	896 063
8	6	50	846 080	896 080
12,5	8	56	846 126	896 126
16	10	63	846 160	896 160
20	10	67	846 200	896 200
25	10	71	846 250	896 250

Materiál: HSS; HSSE

Material: HSS; HSSE

Werkstoff: HSS; HSSE

Mamepuan: HSS; HSSE

# DIN 334 A

**HSS**  
code 836 XXX

Kuželové záhlubníky 60°  
vícebřité  
Countersinks 60°  
Kegelsenker 60°  
Конические шенкера 60°

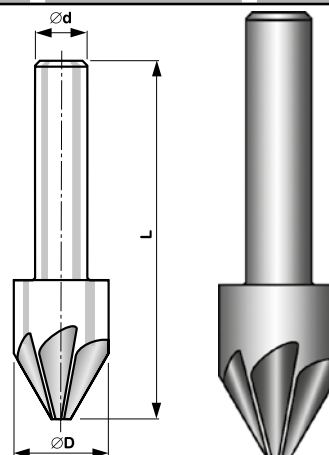

Ø D	Ø d	L	code HSS
8	8	50	836 080
12,5	8	50	836 125
16	10	60	836 160
20	10	63	836 200
25	10	71	836 250

Materiál: HSS

Material: HSS

Werkstoff: HSS

Mamepuan: HSS



**BUČOVICE**  
**TOOLS a.s.**

# DIN 335 A

**HSS**  
code 736 XXX

Kuželové záhlubníky 90°  
vícebřité  
Countersinks 90°  
Kegelsenker 90°A  
Конические шенкера 90°

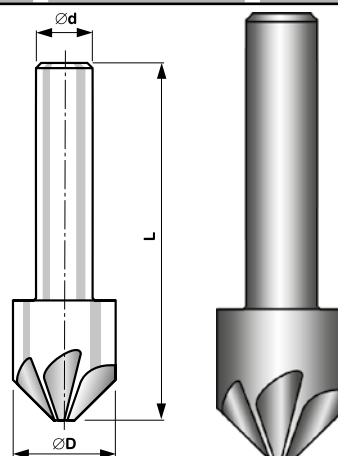

Ø D	Ø d	L	code HSS
8	8	48	736 080
12,5	8	48	736 125
16	10	56	736 160
20	10	60	736 200
25	10	67	736 250

Materiál: HSS

Material: HSS

Werkstoff: HSS

Mamepuan: HSS

**HSS**

code 842 XXX

**HSSE**

code 845 XXX

Odjehlovací  
záhlubníky 60°  
Deburrer countersink 60°  
Entgratungssenker 60°  
Шенкер для очистки  
отверстий от стружки 60°

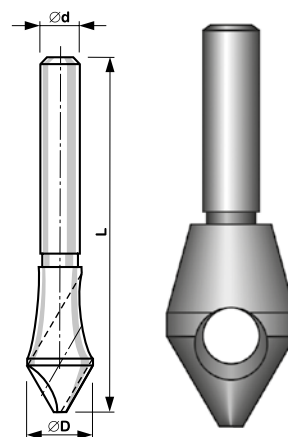

Ø D	Ø d	L	code HSS	code HSSE
2/5	6	46	842 005	845 005
5/10	8	50	842 010	845 010
10/15	10	68	842 015	845 015
15/20	12	86	842 020	845 020

Materiál: HSS; HSSE

Material: HSS; HSSE

Werkstoff: HSS; HSSE

Mamepuan: HSS; HSSE

**BUČOVICE**  
TOOLS a.s.

**HSS**  
code 742 XXX**HSSE**  
code 745 XXX**HSS TiN**  
code 749 XXX**HSSE VA**  
code 893 XXX

**Odjehlovací  
záhlubníky 90°  
Deburrer countersink 90°  
Entgratungssenker 90°  
Шенкер  
для очистки отверстий  
от стружки 90°**

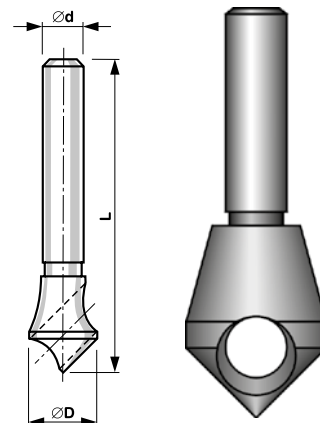

Velikost/Size/Größe/Размер	Ø D	Ø d	L	code HSS	code HSSE	code HSS TiN	code HSSE VA
2/5	10	6	46	742 005	745 005	749 005	893 005
5/10	14	8	46	742 010	745 010	749 010	893 010
10/15	21,5	10	64,5	742 015	745 015	749 015	893 015
15/20	28	12	80	742 020	745 020	749 020	893 020
20/25	35	15	97	742 025	745 025	749 025	893 025
25/30	44	15	115	742 030	745 030	749 030	893 030

Materiál: HSS; HSSE

Material: HSS; HSSE

Werkstoff: HSS; HSSE

Mamepuan: HSS; HSSE

**DIN 1866** (ČSN 22 1605)**HSS**  
code 851 XXX**HSSE**  
code 852 XXX

**Záhlubníky s vřlcovou  
stopkou a vodícím řepem  
Counterbores with  
straight shank and fixed  
pilot  
Flachsenker mit Zylinder-  
schaft und festem  
Цековка с направляю-  
щим пилотом**

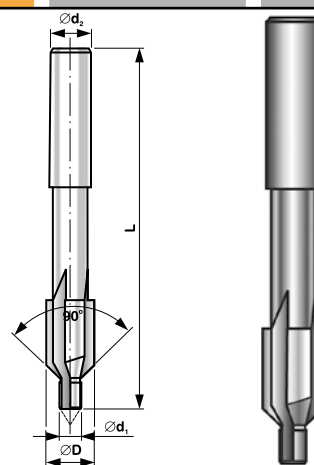

Ø D	Ø d <sub>1</sub>	závit šroubu <sup>x)</sup>	Ø d <sub>2</sub>	L	code HSS	code HSSE
4	1,6*	M 2	4,3	56	851 031	852 031
4	2,2	M 2	4,3	56	851 032	852 032
4,9	2,05*	M 2,5	5	56	851 041	852 041
4,9	2,7	M 2,5	5	56	851 042	852 042
5,7	2,5*	M 3	5	71	851 051	852 051
5,7	3,2	M 3	5	71	851 052	852 052
6,7	2,9*	M 3,5	5	71	851 061	852 061
6,7	3,7	M 3,5	5	71	851 062	852 062
7,8	3,3*	M 4	5	71	851 071	852 071
7,8	4,3	M 4	5	71	851 072	852 072
9,5	4,2*	M 5	8	80	851 091	852 091
9,5	5,3	M 5	8	80	851 092	852 092
11,4	5*	M 6	8	80	851 111	852 111
11,4	6,4	M 6	8	80	851 112	852 112

x) screw thread / Gewinde der Schraube / резьба винта

\*) rozměry vodících řepů přizpůsobené předvrtaným otvorům pro závit / Workmanship marked \* have dimensions of pilot pins adapted to prebored holes for the thread. / Die Ausführungen bezeichnet \* haben die Masse der Führungszapfen dem vorgebohrten Löcher für Gewinde angepasst. / Размеры направляющих пилотов в соответствии с отверстиями для резьбы.

**BUČOVICE  
TOOLS a.s.**

Materiál: HSS

Material: HSS

Werkstoff: HSS

Mamepuan: HSS



**HSS**  
code 541 XXX

**HSSE**  
code 544 XXX

**HSS TiN**  
code 546 XXX

**HSSE TiN**  
code 596 XXX

Sady kuželových  
vrtacích trnů  
Conical peeling  
drills set  
Schälbohrer-Satz  
Набор  
конических свёрл



Norma / Standard / Norm / Norma	kg	axbxc	code	Norma / Standard / Norm / Norma	kg	axbxc	code
Typ - K 1 HSS Typ - K 1 HSSE 	3,5/14; 6/20; 16/30 0,22 0,22	73x17x133 73x17x133	541 801 544 801	Typ - K 1 HSSTiN Typ - K 1 HSSETiN 	3,5/14; 6/20; 16/30 0,22 0,22	73x17x133 73x17x133	546 801 TiN 596 801 TiN
Typ - K 2 HSS Typ - K 2 HSSE 	3,5/14; 16/30 0,17 0,17	73x17x133 73x17x133	541 802 544 802	Typ - K 2 HSSTiN Typ - K 2 HSSETiN 	3,5/14; 16/30 0,17 0,17	73x17x133 73x17x133	546 802 TiN 596 802 TiN
Typ - K 3 HSS Typ - K 3 HSSE 	6/20; 16/30 0,20 0,20	73x17x133 73x17x133	541 803 544 803	Typ - K 3 HSSTiN Typ - K 3 HSSETiN 	6/20; 16/30 0,20 0,20	73x17x133 73x17x133	546 803 TiN 596 803 TiN

**HSS**  
code 541 XXX

**HSSE**  
code 544 XXX

**HSS TiN**  
code 546 XXX

**HSSE TiN**  
code 596 XXX

Sady kuželových  
vrtacích trnů  
Conical peeling  
drills set  
Schälbohrer-Satz  
Набор  
конических свёрл



Norma / Standard / Norm / Norma	kg	axbxc	code
Typ - K 4 HSS 	3/14; 6/20; 16/30 0,56	110x135x45	541 804
Typ - K 4 HSSTiN 	3/14; 6/20; 16/30 0,56	110x135x45	546 804 TiN
Typ - K 4 HSSE 	3/14; 6/20; 16/30 0,56	110x135x45	544 804
Typ - K 4 HSSETiN 	3/14; 6/20; 16/30 0,56	110x135x45	596 804 TiN

**HSS**  
code 641 XXX







**HSSE**  
code 691 XXX

**HSS TiN**  
code 646 XXX

**HSSE TiN**  
code 696 XXX

**Sady  
stupňovitých vrtáků  
Stepped peeling  
drills set  
Stufenbohrer-Satz  
Набор конических  
ступенчатых свёрл**



Norma / Standard / Norm / Norma	kg	axbxc	code	Norma / Standard / Norm / Norma	kg	axbxc	code
Typ - S 1 HSS Typ - S 1 HSSE 	4/12-1; 4/20 0,11 0,11	73x17x133 73x17x133	641 801 691 801	Typ - S 1 HSSTiN Typ - S 1 HSSETiN 	4/12-1; 4/20 0,11 0,11	73x17x133 73x17x133	646 801 TiN 696 801 TiN
Typ - S 2 HSS Typ - S 2 HSSE 	4/12-1; 6/30 0,26 0,26	73x17x133 73x17x133	641 802 691 802	Typ - S 2 HSSTiN Typ - S 2 HSSETiN 	4/12-1; 6/30 0,26 0,26	73x17x133 73x17x133	646 802 TiN 696 802 TiN
Typ - S 3 HSS Typ - S 3 HSSE 	6/30; 6/38 0,46 0,46	73x17x133 73x17x133	641 803 691 803	Typ - S 3 HSSTiN Typ - S 3 HSSETiN 	6/30; 6/38 0,46 0,46	73x17x133 73x17x133	646 803 TiN 696 803 TiN

**HSS**  
code 641 XXX





**HSSE**  
code 691 XXX

**HSS TiN**  
code 646 XXX

**HSSE TiN**  
code 696 XXX

**Sady  
stupňovitých vrtáků  
Stepped peeling  
drills set  
Stufenbohrer-Satz  
Набор конических  
ступенчатых свёрл**



Norma / Standard / Norm / Norma	kg	axbxc	code
Typ - S 4 HSS 	4/12-1; 10/20; 20/30 0,560	110x135x45	641 804
Typ - S 4 HSSTiN 	4/12-1; 10/20; 20/30 0,560	110x135x45	646 804 TiN
Typ - S 4 HSSE 	4/12-1; 10/20; 20/30 0,560	110x135x45	691 804
Typ - S 4 HSSETiN 	4/12-1; 10/20; 20/30 0,560	110x135x45	696 804 TiN

Materiál: HSS; HSSE

Material: HSS; HSSE

Werkstoff: HSS; HSSE

Mamepuan: HSS; HSSE

 **BUČOVICE  
TOOLS a.s.**

**HSS**  
code 641 XXX

**HSSE**  
code 691 XXX

**HSS TiN**  
code 646 XXX

**HSSE TiN**  
code 696 XXX

**Sady  
stupňovitých vrtáků  
Stepped peeling  
drills set  
Stufenbohrer-Satz  
Набор конических  
ступенчатых свёрл**



Norma / Standard / Norm / Norma	kg	axbxc	code
Typ - S 5 HSS Typ - S 5 HSSE 	4/12-1; 4/20/ 6/30 0,6 0,6	110x150x35 110x150x35	641 805 691 805
Typ - S 5 HSS TiN Typ - S 5 HSSE TiN 	4/12-1; 4/20/ 6/30 0,6 0,6	110x150x35 110x150x35	646 805 696 805

**HSS**  
code 648 XXX

**HSSE**  
code 698 XXX

**HSSE TiN**  
code 699 XXX

**Sady  
stupňovitých vrtáků  
Stepped peeling  
drills set  
Stufenbohrer-Satz  
Набор конических  
ступенчатых свёрл**



Norma / Standard / Norm / Norma	kg	axbxc	code
Typ - S 6 HSS Typ - S 6 HSSE 	4/12-1; 4/20/ 6/30 0,6 0,6	110x150x35 110x150x35	648 805 698 805
Typ - S 6 HSSE TiN 	4/12-1; 4/20/ 6/30 0,6	110x150x35	699 805



**BUČOVICE  
TOOLS a.s.**

Materiál: HSS; HSSE

Material: HSS; HSSE

Werkstoff: HSS; HSSE

Mamepuan: HSS; HSSE

**HSS**  
code 741 XXX

**HSSE**  
code 740 XXX

Sady kuželových  
záhlubníků 90°  
Countersinks set 90°  
Kegelsenker-Satz 90°  
Набор конических  
шенкеров 90°



Norma / Standard / Norm / Norma	kg	axbxc	code
Typ - Z 1 HSS Typ - Z 1 HSSE ↔	D 6,3; 8; 10; 12 0,07 0,07	70x33x133 70x33x133	741 801 740 801
Typ - Z 2 HSS Typ - Z 2 HSSE ↔	D 6,3; 8; 10; 16 0,08 0,08	70x33x133 70x33x133	741 802 740 802
Typ - Z 3 HSS Typ - Z 3 HSSE ↔	D 6,3; 10; 12; 16 0,09 0,09	70x33x133 70x33x133	741 803 740 803
Typ - Z 4 HSS Typ - Z 4 HSSE ↔	D 12; 16; 20 0,10 0,10	70x33x133 70x33x133	741 804 740 804

Materiál: HSS; HSSE

Material: HSS; HSSE

Werkstoff: HSS; HSSE

Mamepuan: HSS; HSSE

**HSS**  
code 741 XXX

**HSSE**  
code 740 XXX

**HSS TiN**  
code 746 XXX

**HSSE TiN**  
code 796 XXX

Sady kuželových  
záhlubníků 90°  
Countersinks set 90°  
Kegelsenker-Satz 90°  
Набор конических  
шенкеров 90°



Norma / Standard / Norm / Norma	kg	axbxc	code
Typ - Z 5 HSS Typ - Z 5 HSSE ↔	D 6,3; 8; 10; 12; 16; 20 0,46 0,46	110x150x35 110x150x35	741 805 740 805
Typ - Z 6 HSS Typ - Z 6 HSSE ↔	D 6,3; 8,3; 10,4; 12,4; 16,5; 20,5 0,50 0,50	110x150x35 110x150x35	741 806 791 806
Typ - Z 5 HSS TiN Typ - Z 5 HSSE TiN ↔	D 6,3; 8; 10; 12; 16; 20 0,46 0,46	110x150x35 110x150x35	746 805 796 805

Materiál: HSS; HSSE

Material: HSS; HSSE

Werkstoff: HSS; HSSE

Mamepuan: HSS; HSSE

 **BUČOVICE**  
TOOLS a.s.

**HSS**  
code 746 XXX

**HSSE**  
code 796 XXX

Sady kuželových  
záhlubníků 90°  
Countersinks set 90°  
Kegelsenker-Satz 90°  
Набор конических  
шенкеров 90°



Norma / Standard / Norm / Norma

Typ - Z 7 DIN 335C HSS D 4,3; 5; 6; 6,3; 7; 8; 8,3; 10;  
10,4; 11,5; 12,4; 15; 16,5;

Typ - Z 7 DIN 335C HSSE

19; 20,5; 23; 25;



kg

axbxc

code

0,70

200x115x57

746 807

0,70

200x115x57

796 807

Materiál: HSS; HSSE

Material: HSS; HSSE

Werkstoff: HSS; HSSE

Mamepuan: HSS; HSSE

**HSS**  
code 744 XXX

Souprava bitových  
kuželových záhlubníků  
Bit - countersinks set  
Bit - Kegelsenker-Satz  
Набор битовых  
конических разверток



Norma / Standard / Norm / Norma

Typ - Z 2 bit HSS D 6,3; 8,3; 10,4;  
12,4; 16,5; 20,5



kg

axbxc

code

0,40

140x110x50

744 802

Materiál: HSS

Material: HSS

Werkstoff: HSS

Mamepuan: HSS



**BUČOVICE**  
**TOOLS a.s.**

**HSS**  
code 744 XXX

**Souprava bitových  
kuželových záhlubníků**  
Bit - countersinks set  
Bit - Kegelsenker-Satz  
Набор битовых  
конических разверток



Norma / Standard / Norm / Norma

			kg	axbxc	code
Typ - Z 1 bit HSS 	D 6,3; 8,3; 10,4; 12,4; 16,5	šroubovák s „T“ rukojetí / Screwdriver with „T“ holder / Schraubendreher mit „T“ halter / отвертка с „T“ рукояткой	0,40	140x110x50	744 801

Materiál: HSS

Material: HSS

Werkstoff: HSS

Материал: HSS

**HSS**  
code 742 XXX

**HSSE**  
code 745 XXX

**Sady odjehlovacích  
záhlubníků**  
Deburrer  
countersinks set  
Kegelsenker - Satz  
Набор конических  
шенкеров для очистки  
отверстий от стружки



Norma / Standard / Norm / Norma

			kg	axbxc	code
Typ - Q 1 HSS Typ - Q 1 HSSE 	2/5; 5/10; 10/15 2/5; 5/10; 10/15		0,11 0,11	70x33x133 70x33x133	742 801 745 801
Typ - Q 2 HSS Typ - Q 2 HSSE 	5/10; 10/15; 15/20 5/10; 10/15; 15/20		0,11 0,11	70x33x133 70x33x133	742 802 745 802

Materiál: HSS; HSSE

Material: HSS; HSSE

Werkstoff: HSS; HSSE

Материал: HSS; HSSE

 **BUČOVICE  
TOOLS a.s.**

**HSS**  
code 850 XXX

**Souprava záhlubníků  
s vodícím čepem**  
**Set of counterbores with  
fixed pilot**  
**Flachsenker mit zylind-  
deschaft und festem Sat**  
**Набор цековок с на-  
правляющим пилотом**



Norma / Standard / Norm / Norma

Typ - ZV 1

DIN 373 (ČSN 22 1604) pro závit / for thread /  
für Gewinde / для резьбы M3-M10



D 6x2,5; 8x3,3; 10x4,2; 11x5;  
15x6,8; 18x8,5

kg

axbxc

code

0,65

150x110x35

850 801

Typ - ZV 2

DIN 373 (ČSN 22 1604) pro šroub/ for screw /  
für Schraube / для винта M3-M10



D 6x3,2; 8x4,3; 10x5,3;  
11x6,4; 15x8,4; 18x10,5

0,65

150x110x35

850 802

Materiál: HSS

Material: HSS

Werkstoff: HSS

Материал: HSS



**BUČOVICE  
TOOLS a.s.**