

INSTRUCTION MANUAL

Heavy-Duty Cabinet Table Saw

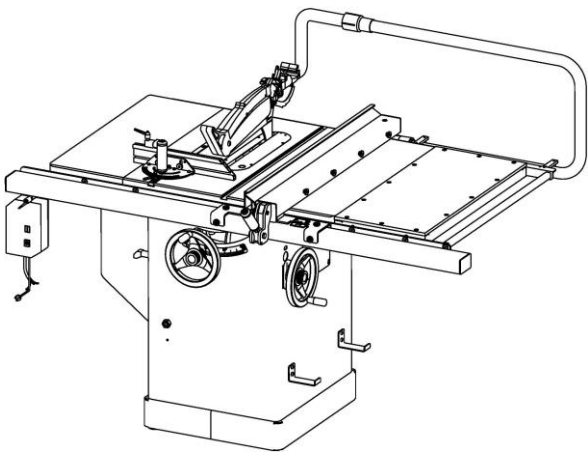

30" Rip Capacity Model

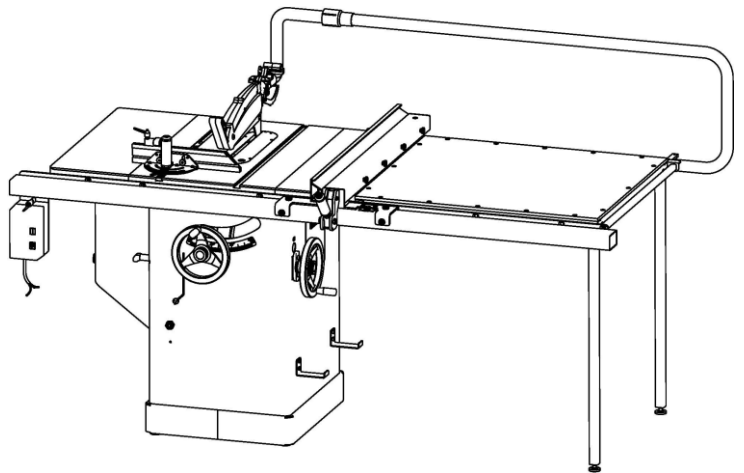

50" Rip Capacity Model

Contents

1. Machine Description	2
1.1 Technical Parameters.....	2
1.2 Feature Identification	3
1.3 Intended Use	3
2. Safety Regulations	4
2.1. General Safety Instructions.....	4
2.2. Table Saw Safety Instructions	4
2.3. Residual Risks.....	5
2.4. Safety Equipment.....	5
3. Installation of the Machine	6
3.1 Transportation of Machines.....	6
3.2 Unpacking.....	6
3.3 Contents.....	7
3.4 Installation.....	9
4. Adjustment	15
4.1 Adjusting the Rip Fence	15
4.2 Aligning the Table T-slot Parallel with the Blade.....	15
4.3 Adjusting the 45°and 90°Positive Stops	15
4.4 Aligning Riving Knife with the Blade.....	16
4.5 Calibrating the Saw Blade Angle DRO	16
5. Operations	17
5.1 Electrical Operation.....	17
5.2 Blade Elevation and Tilting Adjustment	17
6. Maintenance	17
7. Trouble Shooting	18
8. Exploded View and Parts List	19

1. Machine Description

1.1 Technical Parameters

MODEL	DESCRIPTION	MAIN SPECIFICATIONS	STANDARD FEATURES
W0700R	10" Heavy Duty Table Saw	Motor Output Power:2200W (3HP)	Magnetic Switch with OverLoad Protection
		Saw Blade Diameter: 254mm(10")	Quick Lock Saw blade Guard with Anti-Kick Back Pawls
		Arbor Diameter:15.87mm(5/8")	Anti-Kick Back Spreader
		Arbor Speed:4100rpm	No-Through Cut Riving Knife
		Max.Width of Dado:20.6mm(13/16")	Easy Arbor Lock Lever
		Max.Diameter of Dado:200mm(8")	Professional T-Glide Camlock Fence with Aluminum Body
		Max.Cutting Height at 90°:76mm(3")	Standard Table Insert
		Max.Cutting Height at 45°:54mm(2-1/8")	Dado Table Insert
		SAW Blade Tile Direction: Left	Miter Gauge
		Max. Rip Right of Blade 30":762mm(30")	Miter Gauge storage Sleeves
		Max. Rip Right of Blade 50":1270mm(50")	Fence Rest Arms
		Max. Rip Left of Blade: 530mm(13-4/5")	Easy Locking Cabinet Door
		Cast-iron Main Table Size: 740×512mm(26"×20")	Mobile Wheels
		Cast-iron Table Size (With Extension Wings) : 740×1070mm(26"×42")	Arbor Nut Wrench
		Total Table Length 30"(With Extension Wings+30"Extension Table):1410mm(59-2/5")	Push Stick
		Total Table Length 30"(With Extension Wings+50"Extension Table):1920mm(79-1/2")	30" or 50" Phenolic Extension Table
		Main Dust Port Diameter: 100mm	

1.2 Feature Identification

50" Model Refer to **Fig. 1**.

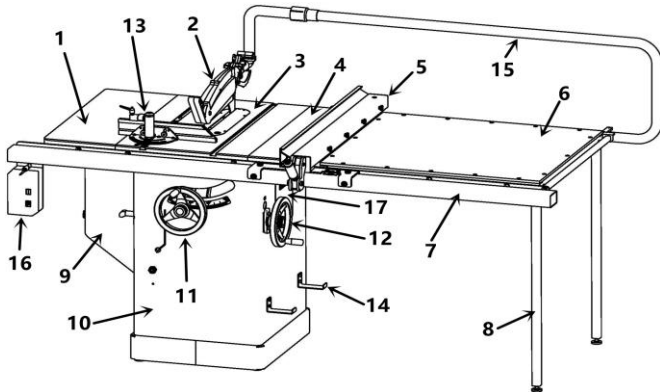

Fig. 1

- | | |
|----|-------------------------------|
| 1 | Left Extension Wing |
| 2 | Blade Guard |
| 3 | Main Table |
| 4 | Right Extension Wing |
| 5 | Fence Assembly |
| 6 | Extension Table |
| 7 | Rail Assembly |
| 8 | Support Leg |
| 9 | Motor Cover |
| 10 | Cabinet |
| 11 | Blade Elevation Hand Wheel |
| 12 | Blade Tilt Hand Wheel |
| 13 | Miter Gauge |
| 14 | Fence Arm Rest |
| 15 | OverArmDustCollection(system) |
| 16 | Magnitic Starter |
| 17 | Service Door |

NOTE:

Fig.1 is only for illustration, and the actual object shall prevail.

1.3 Intended Use

This table saw and the workpiece guide equipment supplied with it are intended to be used exclusively for the following purposes:

- Laminated and unlaminated board materials (e.g. chipboard, coreboard, MDF board, ...)
- Solid wood
- Gypsum plasterboard, Cardboard, Veneer with a suitable clamping device
- Dimensionally stable plastics (thermoset plastics, thermoplastics).

Tools:

- The chosen saw blade must be suitable both for the specific work cycle and for the specific material.
- Only circular blades which are solid chrome vanadium (CV) or tungsten carbide tipped (TCT) and have a diameter of 305mm (12"), arbor size of 15.875 mm (5/8") or 30mm, as well as a maximum mounting width of 20.3 mm are allowed for the main saw.

Site of installation / use:

- The machine is not suitable for use outdoors, or in rooms that are subject to moisture or the risk of explosions.
- The intended use of the machine involves connection to a suitably dimensioned dust extraction system .
- Intended use also involves compliance with our specified operating, maintenance and repair conditions and the safety information contained in the operating instructions.

• The table saw may only be used, set up and maintained by persons who are familiar with the machine and aware of the dangers.

- The pertinent accident prevention regulations as well as any other generally recognized technical safety and industrial health rules must be observed.
- Repair work must be carried out by our own customer service or by an authorized repair center. Only original spare parts are allowed to be used on this machine. We will assume no warranty for any damage that is caused by using non-original spare parts.

2. Safety Regulations

2.1 General Safety Instructions

1. KNOW YOUR MACHINE.

Read and understand the owner's manual and labels affixed to the machine. Learn its application and limitations as well as its specific potential hazards;

2. GROUND THE MACHINE.

In the event of an electrical short, grounding reduces the risk of electrical short;

3. KEEP THE BLADE GUARDS IN PLACE.

Keep in good working order, properly adjusted and aligned;

4. REMOVE THE ADJUSTING TOOLS

Form a habit of checking that the key and adjusting wrenches are removed from the machine before turning it on;

5. KEEP THE WORK AREA CLEAN.

Cluttered areas and benches invite accidents. Make sure the floor is clean and not slippery due to wax and sawdust build-up;

6. AVOID A DANGEROUS ENVIRONMENT.

Don't use machines in damp or wet locations or expose them to rain. Keep the work area well lit and provide adequate surrounding work space;

7. KEEP CHILDREN AWAY.

All visitors should be kept a safe distance from work area;

8. MAKE WORKSHOP CHILD-PROOF.

With padlocks, master switches or by removing starter keys;

9. USE THE PROPER SPEED.

A machine will do a better and safer job when operated at the proper speed;

10. USE THE RIGHT MACHINE.

Don't force the machine or the attachment to do a job for which it was not designed;

11. WEAR THE PROPER APPAREL.

Do not wear loose clothing, gloves, neckties or jewelry (rings, watch) because they could get caught in moving parts. Non-slip footwear is recommended. Wear protective hair covering to contain long hair. Roll up long sleeves above the elbows;

12. MAINTAIN PROPER FOOTING.

Keep proper footing and balance at all time. Do not over-reach to perform an operation;

13. MAINTAIN THE MACHINE WITH CARE.

Keep tools sharp and clean for the best and safest performance;

14. DISCONNECT MACHINES.

Before servicing, when changing accessories or attachments;

15. AVOID ACCIDENTAL STARTING.

Make sure the switch is in the "OFF" position before plugging in;

16. USE RECOMMENDED ACCESSORIES.

Consult the manual for recommended accessories. Follow the instructions that accompany the accessories. The use of improper accessories may cause hazards;

17. NEVER STAND ON THE MACHINE.

Serious injury could occur if the machine tips over. Do not store materials such that it is necessary to stand on the machine to reach them;

18. CHECK FOR DAMAGED PARTS.

Before further use of the machine, a guard or other parts that are damaged should be carefully checked to ensure that they will operate properly and perform their intended function. Check for alignment of moving parts, breakage of parts, mounting, and any other conditions that may affect its operation. A guard or other parts that are damaged should be properly repaired or replaced;

19. NEVER LEAVE THE MACHINE RUNNING UNATTENDED.

Turn the power to "off". Do not walk away from the machine until it comes to a complete stop;

20. ADEQUATE LIGHT

Ensure that adequate general or localized lighting is provided in work area;

2.2 Table Saw Safety Instructions

1. ALWAYS USE A GUARD.

Always use a guard, splitter on all "thru-sawing" operations. Thru-sawing operations are those when the blade cuts completely through the work piece as in ripping or crosscutting;

2. ALWAYS HOLD THE WORK.

Always hold the work firmly against the miter gauge or fence;

3. ALWAYS USE A PUSHSTICK OR PUSH BLOCKS.

Push blocks or push sticks shall be used when cutting small workpieces and in circumstances where it is necessary to push the workpiece against the fence;

4. NEVER PERFORM UNSAFE OPERATIONS.

Never perform any operations "free-hand" which means using your hands to support or guide the work piece. Always use either the fence or the miter gauge to position and guide the work piece;

5. STAND TO THE SIDE WHEN FEEDING MATERIAL.

Never stand or have any part of your body in line with the path of the saw blade;

6. USE CAUTION WHEN REACHING FOR OBJECTS.

Never reach behind or over the cutting tool with either hand for any reason;

7. SAFE CROSSCUTTING OPERATIONS.

Move the rip fence out of the way when crosscutting;

8. ENSURE CORRECT FEEDING OF MATERIAL.

Feed the work into the blade against the direction of rotation;

9. CORRECT USAGE WITH THE FENCE.

Never use the fence as a cut-off gauge when you are cross-cutting;

10. ALWAYS TURN THE POWER TO THE "OFF" POSITION.

When attempting to free a stalled saw blade, always turn the saw to the "off" position;

11. PROVIDE ADEQUATE SUPPORT.

To the rear and sides of the table saw for wide or long work pieces;

12. AVOID KICKBACKS.

Avoid kickbacks (work thrown back towards you) by keeping the blade sharp, by keeping the rip fence parallel to the saw blade, by keeping the splitter and guard in place and operating, by not releasing work before it is pushed all the way past the saw blade, and by not ripping work that is twisted or warped or does not have a straight edge to guide along the fence;

13. AVOID AWKWARD OPERATIONS.

Avoid awkward operations and hand positions where a sudden slip could cause your hand to move into the spinning blade;

14. CORRECT SAW BLADE USAGE.

No saw blade shall be used where the maximum marked speed is lower than the maximum rotational speed of the saw spindle;

15. CHIP AND DUST.

The machine shall be connected to an external chip and dust extraction system;

The dust extraction equipment is to be switched on before commencing machining;

16. CHECK

Periodically check stop time of blade to make sure the completed stop time of the saw blade is less than 10 seconds.

2.3 Residual Risks

1. Take precautions to reduce the hazard of inhalation of harmful dust (e.g. wearing a dust mask);
2. Wear ear protection to prevent hearing loss;
3. Always wear safety glasses. Also, use a face or dusk mask if the cutting operation is dusty;
4. Protect against the hazard of being cut when handling saw blades in the machine or while performing maintenance on the machine;
5. Do NOT try to remove chips while the saw is running or the saw blade is moving;
6. Do NOT use the machine unless all of the guards and other safety devices necessary for the particular operation are in good working order and in place.

2.4 Safety Equipment

When cutting narrow workpieces, a Push Block must be used. Push the work piece against the fence if necessary. A push block can be easily made by the operator as shown in Fig. 2.

If the workpieces is less then 4-3/4" (120 mm), you must use the push stick, as shown in Fig.3, to prevent your hands from getting too close to the saw blade.

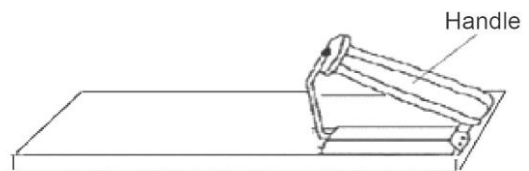

Fig. 2

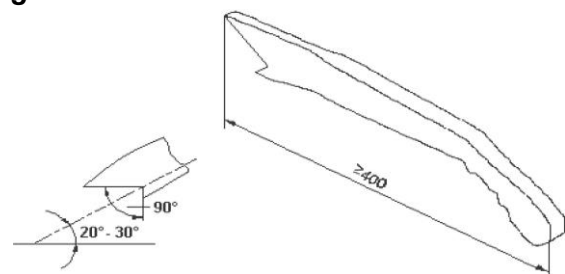

Fig. 3

3. Installation of the Machine

3.1 Transportation of Machines

5.1.1 Transportation and store

This machine has been well packaged and rust preventive measures have been taken at the factory. Care should still be taken to insure that no damage comes from rough handling while moving. Ambient temperatures of -10 to 130 °F (-25 to 55 °C) can be endured by this machine.

Be careful not to expose this machine to rain or other severe weather.

WARNING

While transporting or handling the machine, be careful and let the activity be done by qualified personnel especially trained for this kind of activity!

While the machine is being loaded or unloaded, make sure all persons are out of the way so that no person is crushed by the machine.

Select the proper transportation device according to the weight of the machine. Make sure the lifting capacity of the transportation device is sufficient for the weight of the machine.

3.1.2 Transportation before unpacking

This machine is packed in a robust cardboard box.

Fig. 4 shows the device which can be used to transport the packed crate.



Fig. 4

3.2 Unpacking

Your machine was carefully packaged for safe transportation. Remove the packaging materials from around your machine and inspect it. If you discover that the machine is damaged, please immediately call Customer Service for advice.

Save the containers and all packing materials for possible inspection by the carrier or its agent. Otherwise, filing a freight claim can be difficult.

Note: If you can't find an item on this list, check the mounting location on the machine or examine the packaging materials carefully. Occasionally we pre-install certain components for shipping purposes, or in other packing.

3.3 Contents

Main machine box contents: (Fig. 5-1 ----Fig. 5-5)

A.	Main table saw unit	1
B.	Motor cover	1
C.	Left extension wing	1
D.	Right extension wing	1
E.	Extension table.....	1
	(for 50" Rip Capacity model only)	
F.	Support legs.....	2
H1.	Inner dust port.....	1
H2.	Outer dust port.....	1
J1.	Wrench open-ends 8-10 mm.....	1
J2.	Wrench open-end 13-16 mm.....	1
J3.	Arbor wrench.....	1
K.	Push stick.....	1
L.	Hex wrench set (four pieces)	1
M1.	Dado table insert.....	1
M2.	Zero Clearance insert.....	1
N.	Handwheel handle	2
O1.	Blade guard assembly	1
O2.	Riving knife.....	1
P.	Fence holder.....	1
R.	Miter gauge.....	1

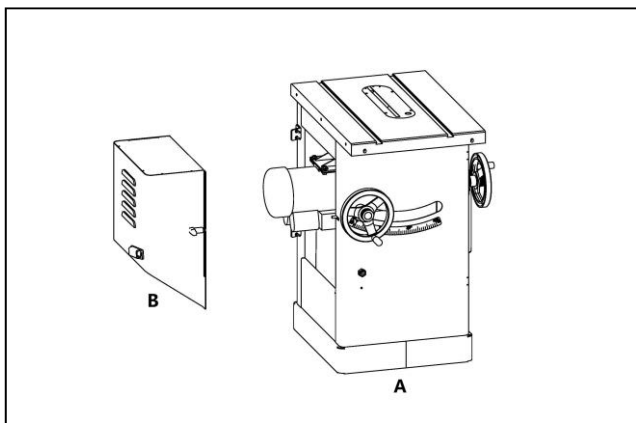

Fig. 5-1

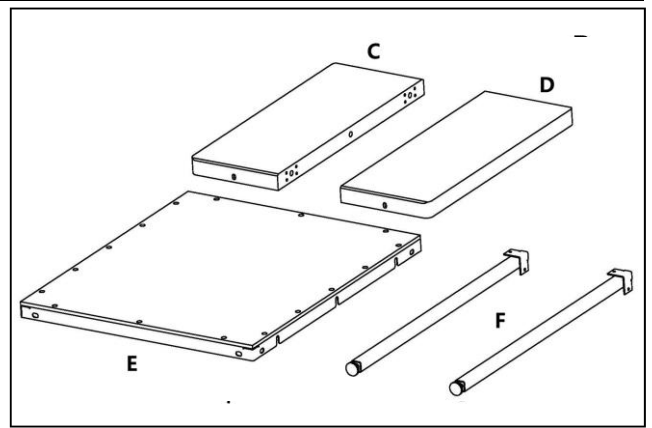

Fig. 5-2

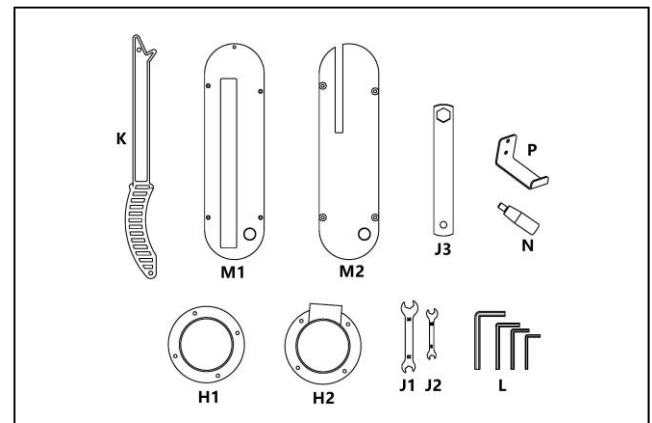

Fig. 5-3

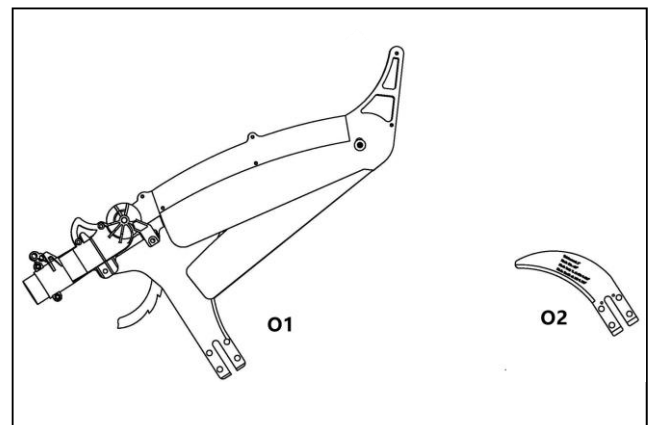

Fig. 5-4

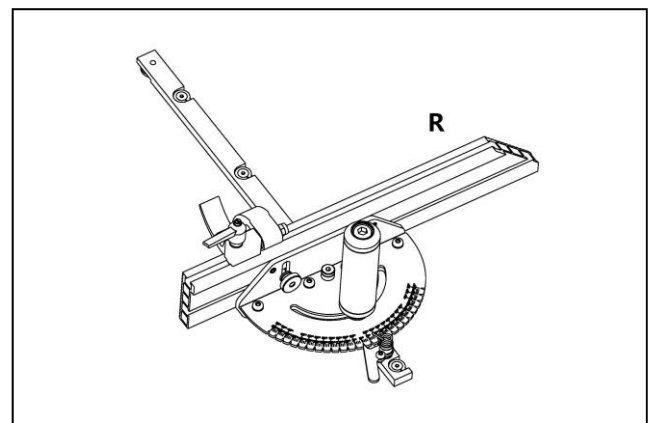

Fig. 5-5

Fence box contents: (Fig. 5-6)

- A. Fence body1
- B. Fence..... 1

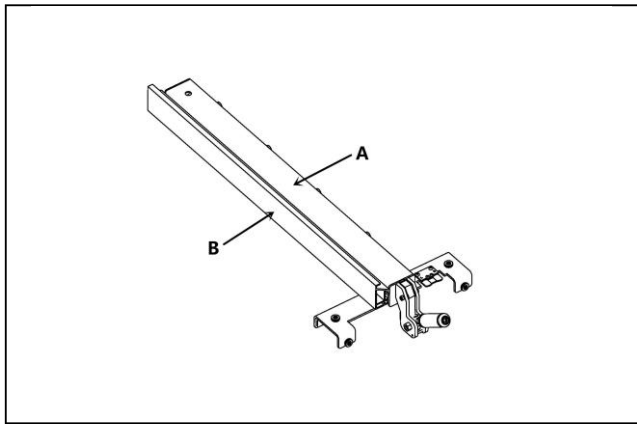

Fig. 5-6

Rail box contents: (Fig. 5-7)

- A. Rear rail.....1
- B. Front rail.....1
- C. Front rail rectangular tube.....1
- D. Front rail tape scale1

Note.

The assembly contains the corresponding hardware which is not shown in the figure, and can be checked with the exploded view.

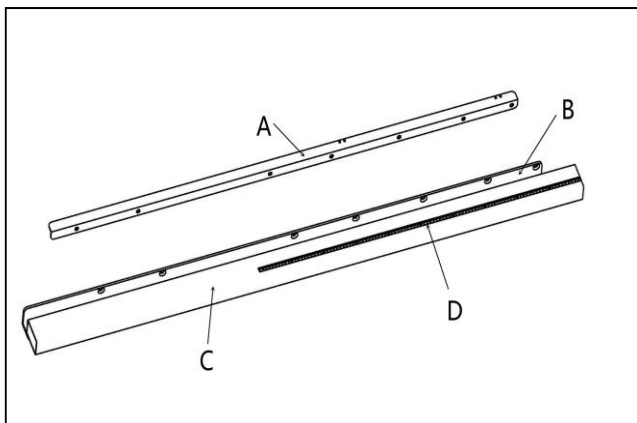

Fig. 5-7

Note.

There are two types of the guide rails, please have a check according to the name plate of the machine:

1. 30 guide rail is for SWDS-2305-30-F.
2. 52"guide rail is for SWDS-2305-50-F.

Over arm box contents: (Fig. 5-8)

- A. Over arm1
- B. Flexible hose (length 0.6 m) 1
- C. Flexible hose(length 1 m)..... 1
- D. Bracket2

Note.

The assembly contains the corresponding hardware which is not shown in the figure, and can be checked with the exploded view.

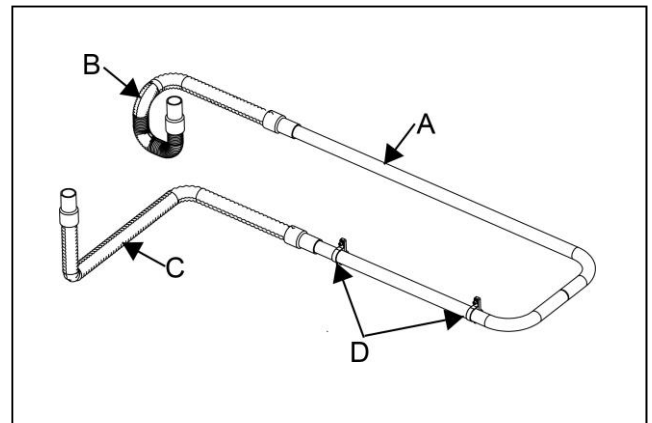

Fig. 5-8

3.4 Installation

Before beginning assembly, take note of the following precautions and suggestions:

FLOOR: This tool distributes a large amount of weight over a small area. Make certain that the floor is capable of supporting both the weight of the machine and the operator. The floor should also be a level surface. If the unit wobbles or rocks once in place, be sure to eliminate the wobble by using shims.

WORKING CLEARANCES: It is important to maintain a free area of 31-1/2" (0.8 m) around the machine, which is required for the working area. If any long material is to be cut, it is necessary to have sufficient room both in front of the machine as well as behind it for material infeed and outfeed.

OUTLET PLACEMENT: Outlets should be located close enough to the machine so that the power cord or extension cord is not in an area where it would cause a tripping hazard.

WARNING

DO NOT assemble the machine until you are certain that the machine is not plugged in and the power switch is in the OFF position.

DO NOT connect the machine to the power source until you read and understand the entire User Manual.

3.4.1 Remove the pallet

The machine is fixed on the pallet by M8 hex bolts. Before installing, please take off the accessories on the pallet and in the cabinet. Then move the machine out after removing the set bolts under the pallet, as shown in **Fig. 6**. Locate the machine at appropriate place.

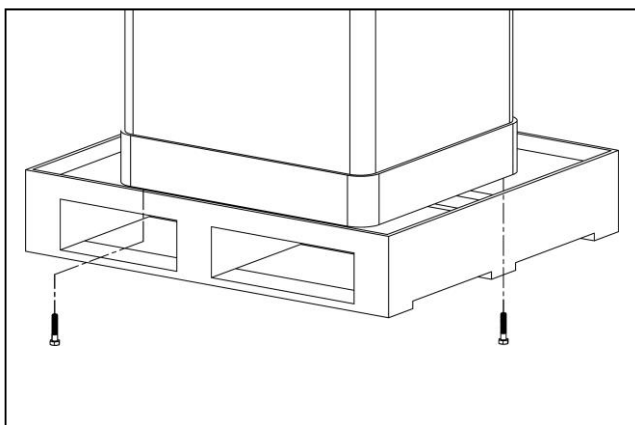

Fig. 6

3.4.2 Hand-wheel handle installation

Install the handle into the Blade Tilt hand-wheel as shown in **Fig. 7**.

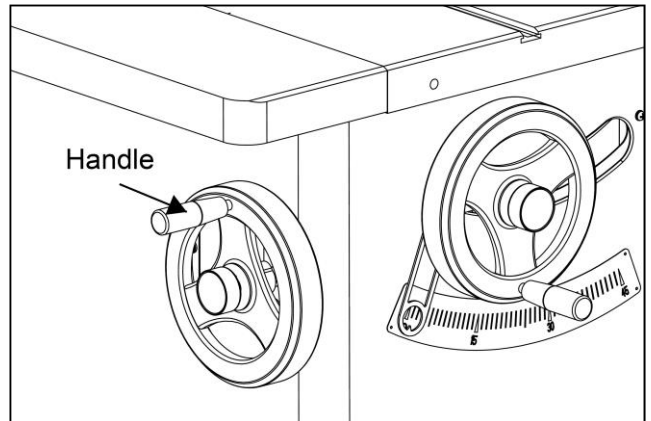

Fig. 7

3.4.3 Extension wings installation (**Fig.8**)

The machine is equipped with a cast iron extension wing on each side of the main table. The mounting bolts of extension wings are pre-mounted in the threaded holes on the main table sides. Install the extension wings as follows:

1. Remove the screws from the sides of the main table;
2. Inspect the extension wings and main table mating surfaces for burrs or foreign materials that may inhibit assembly; the mating edges of the tables must be clean and flat, use a wire brush or sand paper if necessary to clean up the edges;
3. Attach the wings to the main table by using the screws removed in step 1;
4. Use a straightedge to check whether that the main table is coplanar with the extension wing. If not, use a strip of masking tape to shim the extension wing up or down, as directed by the arrow in **Fig. 8**.

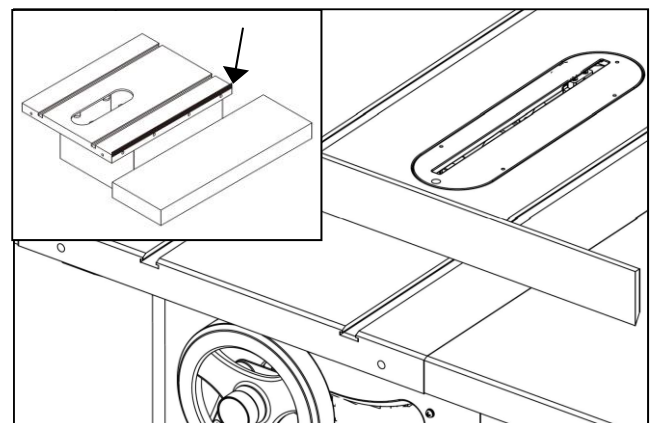

Fig. 8

3.4.4 Install the rail & extension table

1. Install the rail and extension table as breakdown shows.

Before tightening the rear rail, check to make sure the top edge of the rear rail is lower than the T-slot, as shown in Fig. 9.

Ensure that the extension table is coplanar with the main table.

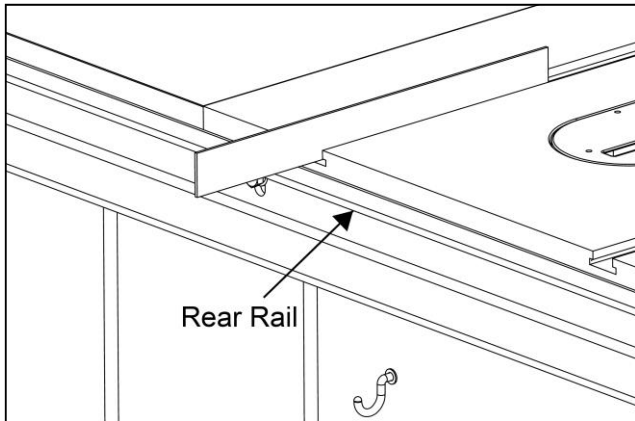

Fig. 9

2. Install the fence on the rail on the right hand side of the blade as shown in Fig. 10.

⚠ NOTICE

If you need to use the fence on the left side of the blade, remove the knobs (A), as shown in Fig.10, and move the fence plate and locking bar to the right side of the fence body, secure them on the left side of the fence body.

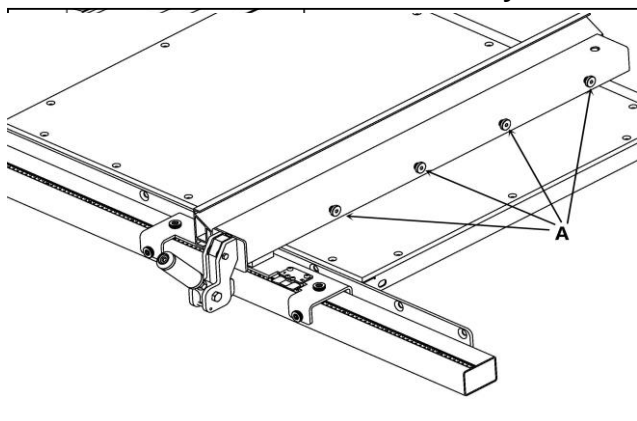

Fig. 10

3. Check the fence parallelism and perpendicularity (Fig.11)

As shown in Fig.11, after securing the fence, ensure that the fence is parallel to the miter slot, which is parallel to blade at any locations. And make sure that the distance $L_1 > L_2$, $L_1 - L_2 < 1/64$ ", which creates a slightly larger opening between the

fence and the blade, at the rear of the blade, to reduce the risk of workpiece binding or burning as it is fed through the cut.

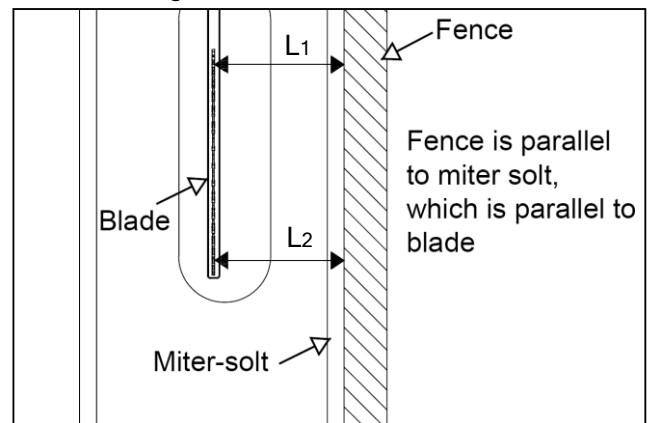

Fig. 11

4. Adjust the parallelism and perpendicularity of the fence (Fig.12)

If the fence or blade is not parallel to the T-slot, or the fence is not perpendicular to the table, you can adjust as following content:

a. Align the the parallelism between the blade and T-slot.

Before aligning perpendicularity or parallelism of the fence, you must align the parallelism between the blade and T-slot, refer to chapter 6.2 **Aligning the Table T-slot Parallel with the Blade.**

b. Align the the parallelism between the fence and T-slot or blade.

By adjusting the set screw (A), you can adjust the parallelism between fence and blade, also you can adjust the locking strength. By adjusting the bolt marked in a circle as shown in Fig. 12, you can adjust the the perpendicularity between the fence and table. By adjusting the set screw (B), you can adjust the sliding smoothness of the fence.

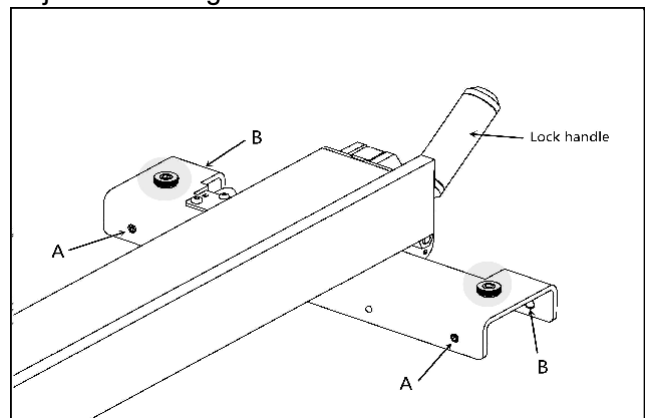

Fig. 12

⚠ NOTICE

By adjusting the support screw (not shown) at the underneath of the fence, you can raise or lower the fence to ensure that the underneath of the fence is parallel to the table.

3.4.5. Post the tape scale use the pointer window (Fig.13)

The machine features a Hi-Low fence with two pointer windows. As shown in Fig.13. The pointer

window (A) is for the lower fence while pointer window (B) is for the high fence. You can micro-adjust the position of pointer window by loosening the screws (C) and (D).

Post the Tape Scale

Place the fence as a high fence, slide the fence against the saw blade, and lock it in place; Place the front rail tape scale on the fence tube, make sure it is parallel with the tube, and the "0" end is directly under the red line on the pointer window (B), lightly mark the "0" location on the tube with a pencil, then remove the fence; peel the tape and carefully align the "0" mark on the scale with the pencil mark you made.

Calibrate the Pointer Window

Place the fence as a high fence, as shown in Fig.13. Slide the fence against the blade, check that if the "0" mark is directly under the red line on the pointer window (B), if any deviation occurs, loosen the screws (C&D), micro-adjust the window, so that the red line on the window is over the "0" mark on the tape, then secure the screws (C&D).

Place the fence as a lower fence. Slide the fence against the blade, check that if the "0" mark is directly under the red line on the pointer window (A), if any deviation occurs, loosen the screws, (C&D), micro-adjust the pointer window, so that the red line on the window is over the "0" mark on the tape, then secure the screws (C&D).

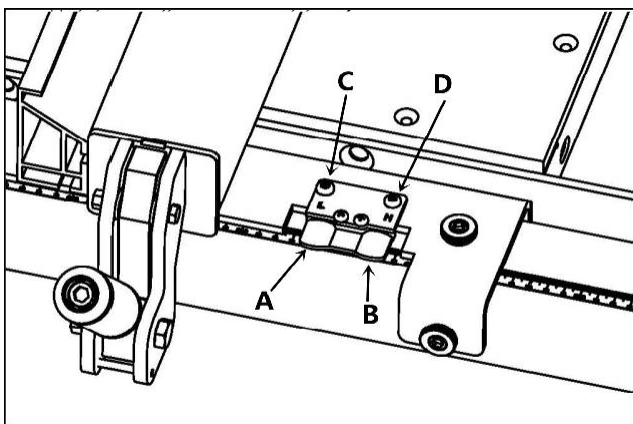

Fig. 13

3.4.6 Install the switch (Fig.14)

The switch is mounted on the lower right side of the guide tube by using two sets of bolts which are pre-installed on the guide tube.

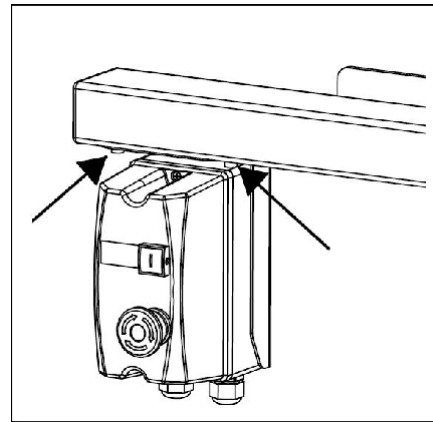

Fig. 14

3.4.7 Install the blade

1. Remove the table insert;
2. Rise the arbor all the way up and set the blade angle at 0°;
3. Remove the arbor nut and arbor flange from the arbor, slide the saw blade onto the arbor, making sure the teeth face the front of the saw, then install the arbor flange and arbor nut onto the blade;
4. Press the arbor lock pin, and use the included wrench to tighten the arbor nut refer to Fig. 15.

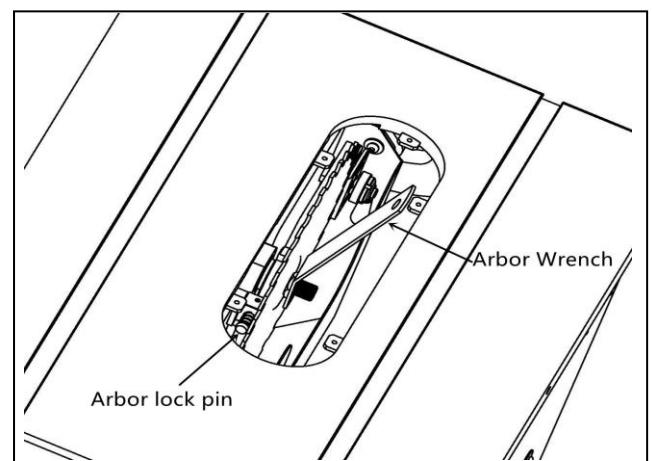

Fig. 15

3.4.8 Install the blade guard

1. Remove the table insert;
2. Unlock the handle. **Fig. 16**

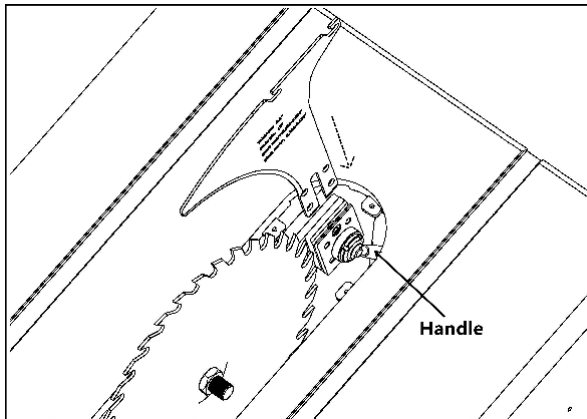

Fig. 16

3. Slide the blade guard spreader all the way down into the block, then lock the handle. **Fig. 16**
4. Slide the blade guard onto the spreader, tighten the lock knob. **Fig. 17**

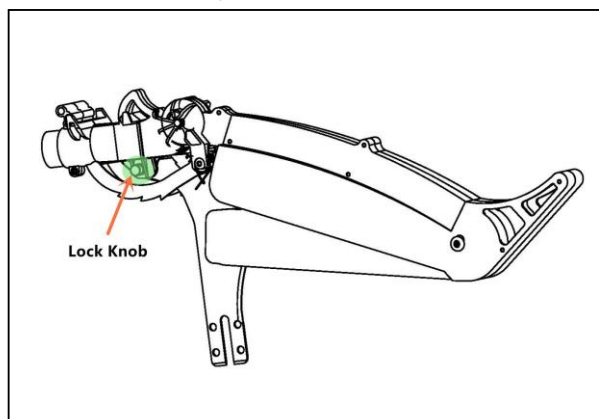

Fig. 17

5. Re-lock the handle.

⚠ WARNING

Check if the saw blade is tightened before operating the machine.
Give the spreader an upward tug to verify if it is locked in place.

3.4.9 Extraction system

⚠ NOTICE

A dust collection device should be used by the customer. The dust extraction equipment must be switched on before commencing machining.

1. Installation of the Dust Outlet (**Fig.18**)

The dust outlet is pre-connected with the flex pipe and placed in the cabinet. Disconnect the flex pipe with the dust outlet and pass the pipe through the cabinet. Then reconnect the flex pipe with the dust outlet and secure the dust outlet on the cabinet.

Note: The mounting hardware of the dust outlet is pre-mounted on the cabinet.

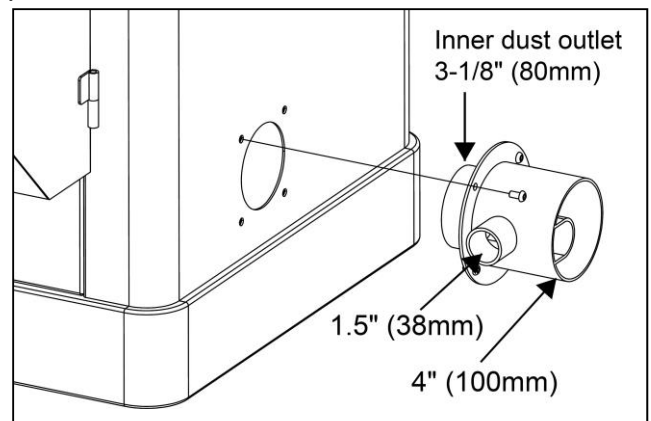

Fig. 18

2. Installation of the over arm (**Fig.19**):

- a. Fit the bracket (A) to the rear rail with screw (B).
- b. Fit the over arm to the bracket (A) with clip (C).
(Total 2 sets of clasps)
- c. Connect the pipe (1.5") provided by us to the dust outlet as **Fig. 22** shows..

Note. All the hardware here is pre-mounted on the over arm assembly.

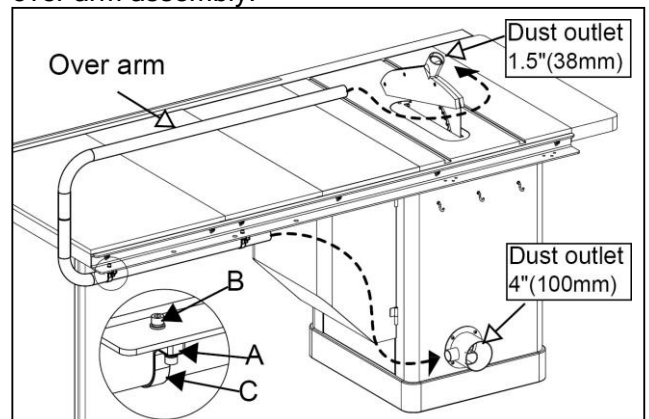

Fig. 19

Requirements for the dust collector:

1. Required air flow: 470 CFM (800 m³/h).
2. Ensure pressure drop of each dust collector outlet carrying air current speed: 1100Pa
3. Dry chips: 3937 FPM (20 m/s).
4. Wet chips: 5511 FPM (28 m/s). (water content is equal to 18%)

3.4.10 Motor cover installation

Install the motor cover by inserting the door pins into the hinge sockets on the cabinet as shown in **Fig. 20**.

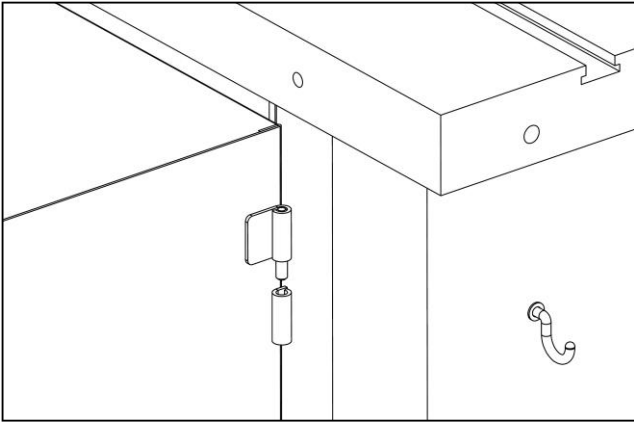

Fig. 20

3.4.11 Electrical installation

⚠ WARNING

Wiring should only be done by professional electricians.

Always make sure the machine is properly grounded. All exposed conductive parts should be connected to the protective ground circuit.

An over-voltage protection device should be provided by end user.

The circuit breaker shall be installed to supply electric power to this machine, in order to protect people against electrical shock due to incidental contact.

Check that the voltage and frequency required by the machine, which is shown on the machine's name plate, correspond to the electric power supply voltage and frequency.

Ensure IP54 protection class for the incoming cable when the finished installation is in place.

Checking:

After finishing wiring in place, at minimum, check the following items:

1. Check the direction of motor and change the wiring if necessary.
2. Check the components for defects, such as damaged cable or plug.
3. Check the function of the "OFF" button.

ELECTRICAL DIAGRAM

3HP/230V/50Hz/1PH

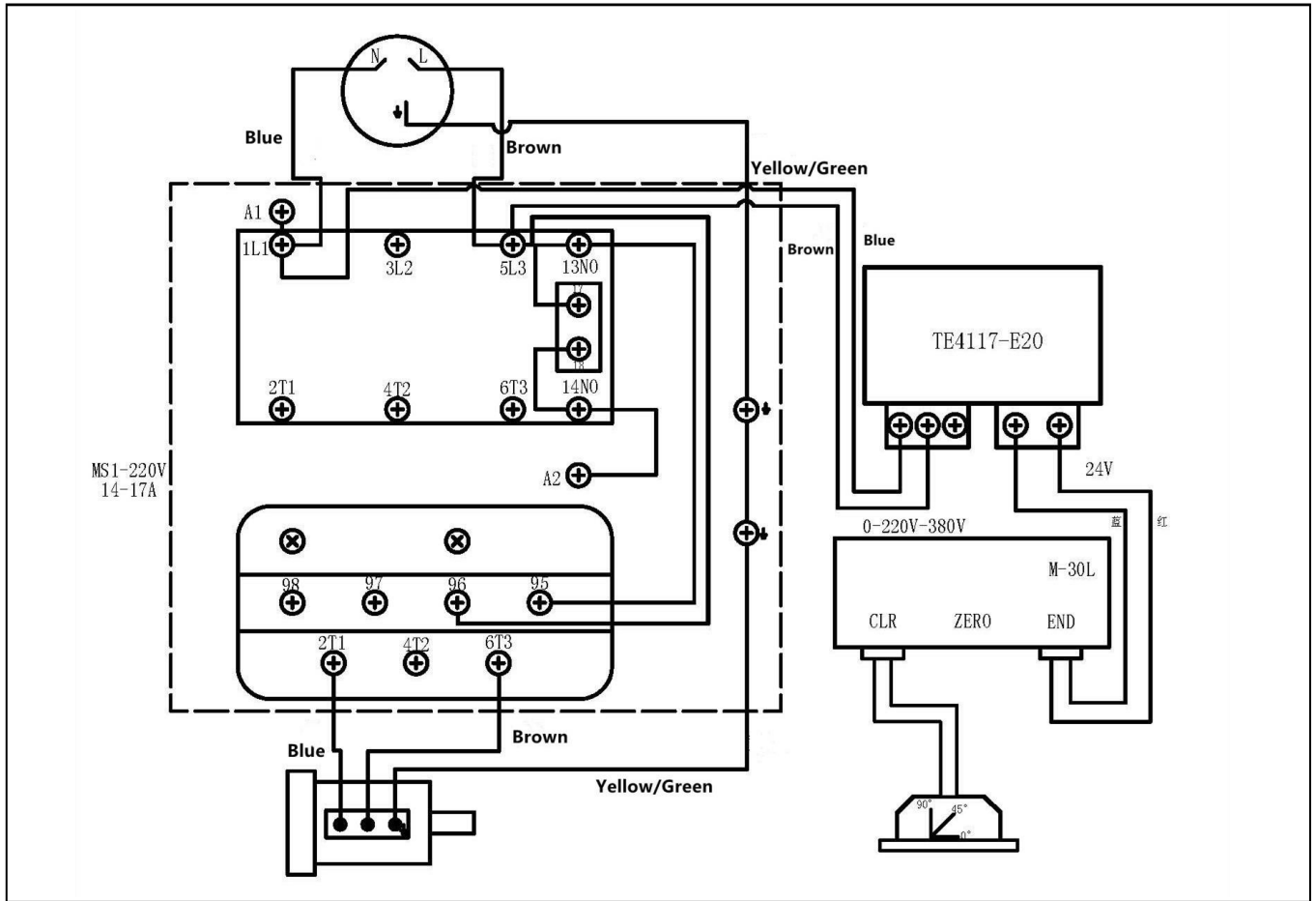

Remark:

1. The colour of single core may differ with the illustration above in different areas.
2. Single-phase power supply range: 200-240 V.

4. Adjustment

⚠ NOTICE

Before operation, Please make adjustments as followings:

4.1 Adjusting the Rip Fence

Before using the rip fence, the parallelism and perpendicularity must be aligned correctly. Please refer to chapter 5.4.4 Install the rail & fence.

4.2 Aligning the Table T-slot Parallel with the Blade

1. The table T-slot must be aligned parallel with the blade. Using a combination square measure the distance from the back edge of the blade to the table T-slot. Pivot blade forward 180° and re-measure the distance using the exact same point on the blade. The difference between both measurements must be less than 0.2mm. Refer to **Fig. 21**.

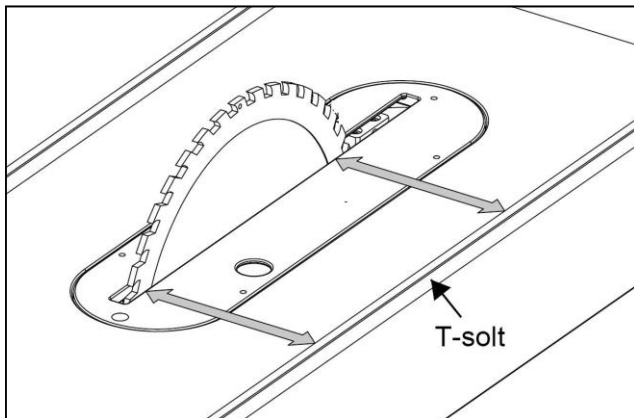

Fig. 21

2. If an adjustment is necessary, loosen the screws identified in **Fig. 22** which mount the table to the cabinet. Make the needed adjustment until both measurements are equal or less than 0.2 mm. and re-tighten the screws.

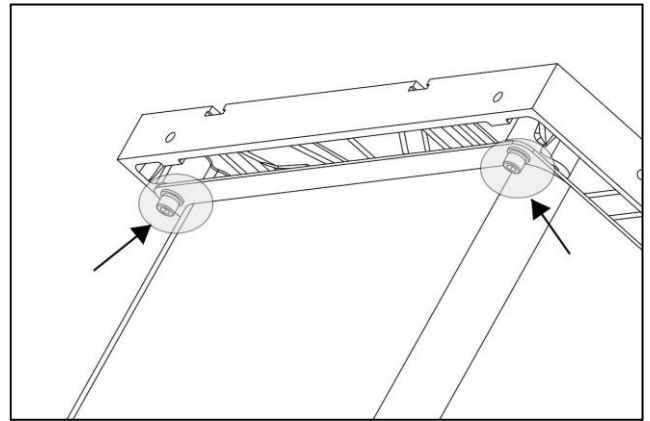

Fig. 22

4.3 Adjusting the 45° and 90° Positive

Stops

The tilt mechanism has adjustable stops for 45° and 90°. The machine comes factory-set but should any positioning deviation of the blade occur, you can re-adjust the stops. Refer to **Fig. 23**.

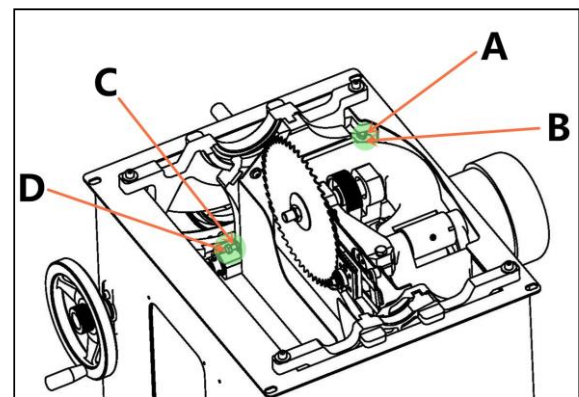

Fig. 23

To adjust the 90° Positive Stop: open the motor cover on the right side of the machine. Then loosen the locking nut (A) and adjust the limit screw (B) until it contacts with the positive stop. Tighten the locking nut(A).

To adjust the 45° Positive Stop: loosen the screws of the repair panel on the left side of the machine and take off the repair panel. Then loosen the locking nut(C) and adjust the limit screw (D) until it contacts with the positive stop. Tighten the locking nut(C).

4.4 Aligning the Riving Knife with Blade

The riving knife must be aligned with the blade. If not properly aligned, the riving knife will force the workpiece sideways during the cut, increasing the risk of kickback. Place a straightedge against the blade and the riving knife and check if the riving knife is in the "alignment zone," refer to **Fig. 24**.

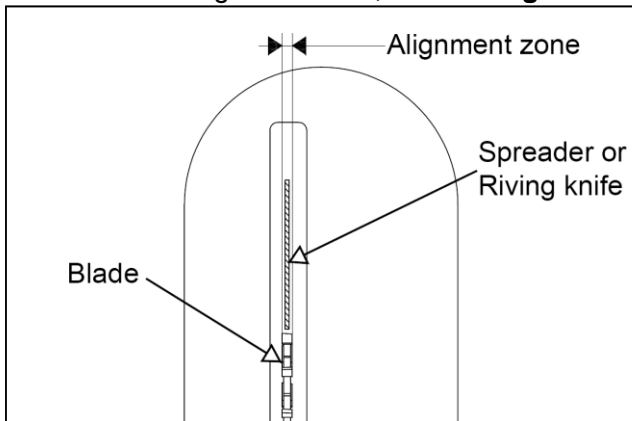

Fig. 24

If it is not aligned properly, please adjust as following (**Fig. 25**):

1. Disconnect the saw from the power source.
2. Remove the table insert.
3. Adjust the set screws (A) in or out until the alignment is perfectly parallel.
4. Re-install the table insert.

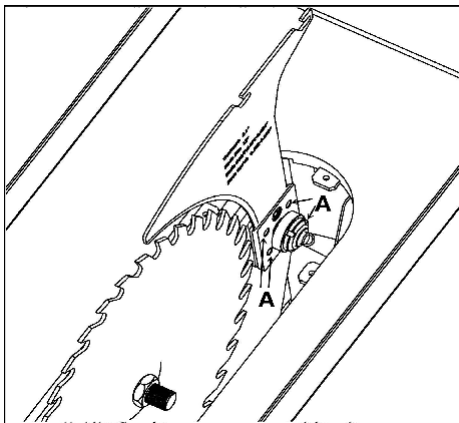

Fig. 25

! NOTICE

1. Riving knives shall have a thickness less than the width of a cut (kerf) and at least 0.2mm greater than the saw blade plate. As shown in **Fig. 26**.

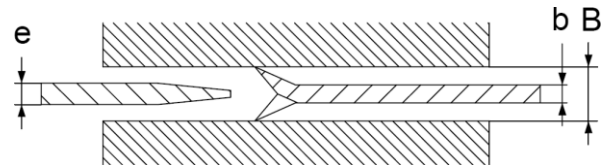

Fig. 26

Key:

e riving knife thickness

b saw blade base

B kerf (width of saw blade cut)

2. The distance of the riving knife from the gear rim must be between 3 mm and 8 mm measured radially through the center of the saw spindle. As shown in **Fig. 27**.

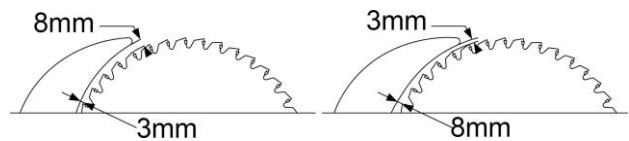

Fig. 27

3. The highest point of the riving knife must be set beneath the topmost teeth.

4.5 Calibrating the Saw Blade Angle DRO (Optional)

1. Using the square to adjust the saw blade to 90°.
2. Press the ZERO button for few second, until the number on screen showing 0.
3. Using the square to adjust the saw blade to 45°.
4. Press the END button for few second, until the number on screen showing 45.

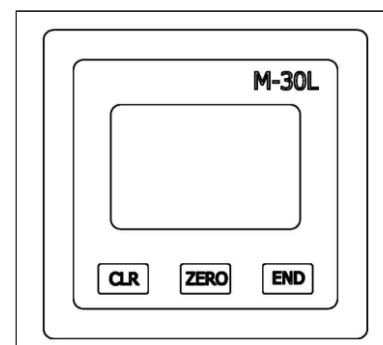

Fig. 28

5. Operations

5.1 Electrical Operation

Two types of the switches are alternative for your machine, the actual object shall prevail.

Refer to **Fig. 28 & Fig.29**

“ON” Button: Start the machine.

“OFF” Button: Stop the machine.

Hole for Safety Lock: While not using the machine, insert the safety pin to prevent accidental start up.

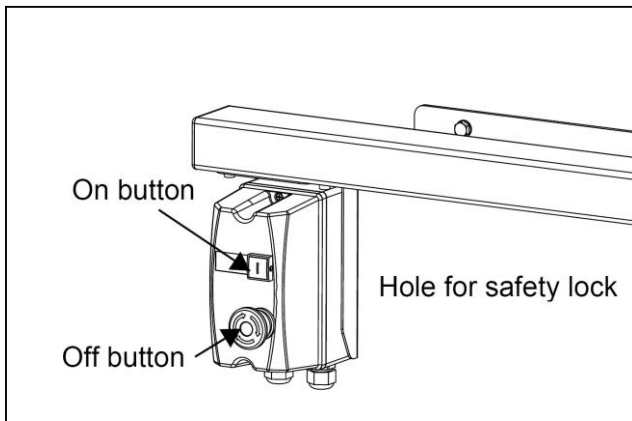

Fig. 29

5.2 Blade Elevation and Tilting Adjustment

To adjust the blade elevation : Loosen the lock knob (C) as shown in **Fig. 30** and turn the elevation hand wheel (D). When the desired height is obtained, re-tighten the knob (C). The blade should be raised 1/8” to 1/4” above the top surface of the material being cut.

To adjust the blade tilting : Loosen the lock knob (B) and turn the hand wheel (A). When the desired angle is obtained, re-tighten the knob (B).

Refer to **Fig. 30**.

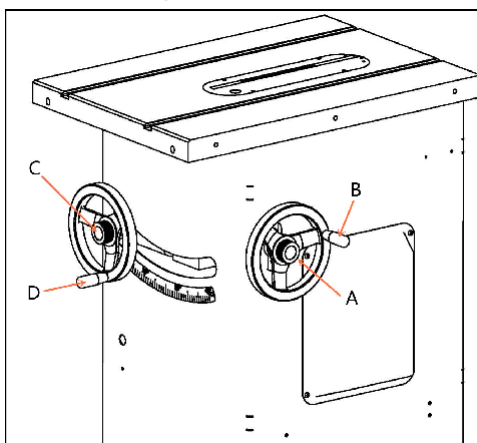

Fig. 30

6. Maintenance

This table saw has TEFC motor and sealed lubricated bearings, which requires very little maintenance other than minor lubrication and cleaning. Please do the maintenance as following contents.

LUBRICATION

Clean off the wood chips on the worm gears and trunnions and apply the grease to keep them lubricated.

Lubricate once a month.

CLEANING

Clean the wood chips on the table surface and in the cabinet.

Clean once a day.

CHANGING BELT

⚠ WARNING

Make sure the power cord is disconnected from the power source!

1. Lower the blade completely, then open the motor cover (right side), remove the repair panel (left side), refer to **Fig. 31**.
2. Loosen the hex bolt that secures the motor and raise the motor fully to remove tension on the V-Ribbed belt. Roll the V-Ribbed belt off.
3. Raise the motor and install a new V-Ribbed belt onto the pulleys, lower the motor to tension the V-Ribbed belt, then tighten the cap screws.
4. Close the motor cover and repair panel.

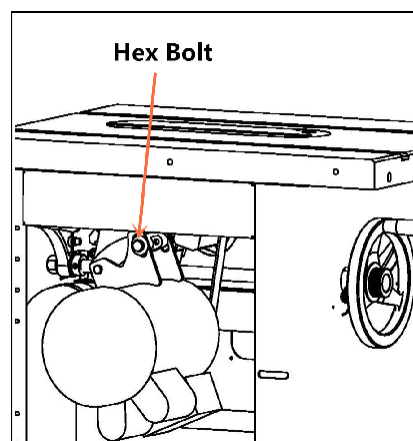

Fig. 31

7. Trouble Shooting

PROBLEM	SOLUTION
<p>SAW WILL NOT START</p> <ol style="list-style-type: none"> 1. Saw not plugged in. 2. Fuse blown or circuit breaker tripped. 3. Cord damaged. 	<ol style="list-style-type: none"> 1. Plug in saw. 2. Replace fuse or reset circuit breaker. 3. Have cord replaced by a certified electrician.
<p>OVERLOAD KICKS OUT FREQUENTLY</p> <ol style="list-style-type: none"> 1. Extension cord too long or gauge size too small. 2. Feeding stock too fast. 3. Blade in poor condition (dull, warped, gummed). 4. Blade binding due to misaligned rip fence. 5. Blade binding due to warped wood. 6. Low house current. 	<ol style="list-style-type: none"> 1. Replace with adequate size cord 2. Feed stock more slowly. 3. Clean or replace blade. 4. Check and adjust the rip fence. Refer to rip fence instructions. 5. Select another piece of wood. 6. Contact your electrical company.
<p>DOES NOT MAKE ACCURATE 45 AND 90 RIP CUTS</p> <ol style="list-style-type: none"> 1. Positive stop(s) not adjusted properly. 2. Tilt angle pointer not set properly. 	<ol style="list-style-type: none"> 1. Check blade with square and adjust positive stop. 2. Check blade with square and adjust pointer to zero.
<p>MATERIAL PINCHES BLADE WHEN RIPPING</p> <ol style="list-style-type: none"> 1. Rip fence not aligned with blade. 2. Warped wood. 	<ol style="list-style-type: none"> 1. Check and adjust rip fence. 2. Select another piece of wood.
<p>MATERIAL BINDS ON SPLITTER</p> <ol style="list-style-type: none"> 1. Splitter not aligned correctly with blade. 	<ol style="list-style-type: none"> 1. Check and align splitter with blade.
<p>SAW MAKES UNSATISFACTORY CUTS</p> <ol style="list-style-type: none"> 1. Dull blade. 2. Blade mounted backwards. 3. Gum or pitch on blade. 4. Incorrect blade for work being done. 5. Gum or pitch on table causing erratic feed. 	<ol style="list-style-type: none"> 1. Replace blade. 2. Turn blade around. 3. Remove blade and clean with turpentine and steel wool. 4. Change the blade. 5. Clean the table with turpentine and steel wool.
<p>BLADE DOES NOT COME UP TO SPEED</p> <ol style="list-style-type: none"> 1. Extension cord too light or too long. 2. Low house current. 3. Motor not wired for correct voltage. 	<ol style="list-style-type: none"> 1. Replace with adequate size extension cord. 2. Contact your electric company. 3. Refer to motor and /or nameplate.
<p>MACHINE VIBRATES EXCESSIVELY</p> <ol style="list-style-type: none"> 1. Table not mounted securely to cabinet stand. 2. Stand is on uneven floor. 3. Damaged saw blade. 4. Bad V-Ribbed belt. 5. V-Ribbed belt is not tensioned properly. 6. Improper motor mounting. 7. Loose hardware. 	<ol style="list-style-type: none"> 1. Tighten all mounting hardware. 2. Reposition on flat level surface. 3. Replace blade. 4. Replace V-Ribbed belt. 5. Adjust V-Ribbed belt tension. 6. Check and adjust motor mounting. 7. Tighten all nuts, bolts and set screws.

ITEM	DESCRIPTION	Q' TY
201	Zero Gap Cover Plate	1
202	Tenon Cover Plate	1
203	Set Screw M6 x 6	3
204	Set Screw M6 x 12	12
205	Standard Cover Plate	1
206	Magnet	3
207	Cap Screw M8 x 35	4
208	Angle Iron Of Rear Guide Rail	1
209	Workbench	1
210	Extended Wing	2
211	Front Rail Angle Iron	1
212	Guide Square Tube	1
213	Square Plug 76.2*50.8	2
214	Switch Board(Magnetic Starter)	1
215	Magnetic Starter	1
216	Connection	1
217	Power Cord	1
218	Hex Bolt M8 x 20	2
219	Cap Screw M10 x 35	6
220	Set Screw M8 x 8	16
221	Fixing Plate	1
222	Flat Head Screw M5 x 8	2
223	Washer 8	13
224	Lock Washer 8	13
225	Nut M8	10
226	Cap Screw M6 x 12	14
227	Lock Washer 6	10
228	Washer 6	14
229	Flat Head Screw M8 x 35	7
230	Reinforcing Bracket	1
231	30 Inch Auxiliary Extension Table	1
232	Cap Screw M8 x 20	1
233	Washer 10	8
234	Lock Washer 10	8
235	Cap Screw M10 x 25	2
236	Button Head Screw M6 x 16	3
237	External Suction Pipe 2	1
238	Interface	2
239	Bracket	1
240	Bracket Fixing Plate	2
241	External Suction Pipe 1	1
242	Riding Card ϕ 38	2

Trunnion Diagram

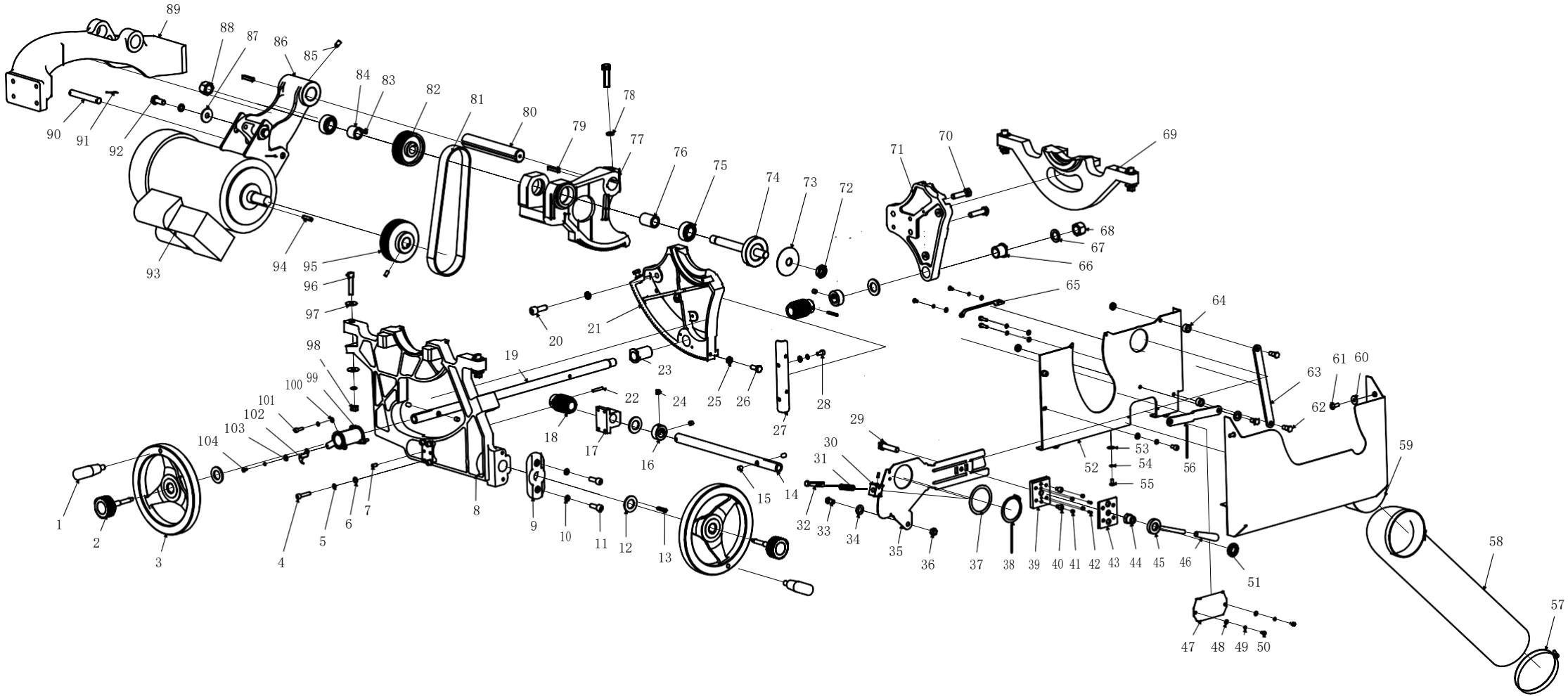

Trunnion Part List

ITEM	DESCRIPTION	Q' TY	ITEM	DESCRIPTION	Q' TY	ITEM	DESCRIPTION	Q' TY
1	Handwheel Handle M10*100	2	36	Lock Nut M8	2	71	F-Trunnion Hanging Plate	1
2	Handwheel Locking	2	37	Gasket Plate	1	72	Square Nut M16*2	1
3	Handwheel	2	38	E-Retaining Ring ϕ 52	1	73	Saw Gland	1
4	Cap Screw M6*30	4	39	C-Plate Fixing Plate	1	74	Saw Shaft	1
5	Lock Washer 6	12	40	Cap Screw M6*8	2	75	Bearing 6203	2
6	Washer 6	10	41	Set Screw M6*6	4	76	L-Fixing Sleeve	1
7	Set Screw M6*12	6	42	Set Screw M4*10	3	77	Saw Shaft Sleeve	1
8	R-Trunnion Rotating Plate	1	43	C-Plate Locking Plate	1	78	Lock Washer 10	7
9	Flange	1	44	C-Plate Lock Nut	1	79	Key 6*30	2
10	Lock Washer 8	6	45	C-Plate Locking Handle	1	80	Fixed Shaft	1
11	Cap Screw M8*25	2	46	C-Plate L-Handle Sleeve	1	81	P-Wedge Belt PJ10Z260J	1
12	Spacer (ϕ 35- ϕ 20-3)	4	47	Fixed Baffle	1	82	Pulley	1
13	Flat Bond 5*25	2	48	Washer 4	4	83	Key 5*16	1
14	Angle Turbin Shaft	1	49	Lock Washer 4	5	84	S-Fixing Sleeve	1
15	Handwheel Locking Column	4	50	Button Head Screw M4*8	4	85	Set Screw M8*12	1
16	Fixing Sleeve	2	51	Round Nut M16*1.5	1	86	Motor Handing Board	1
17	Angle Screw Fixing Block	1	52	Fixing Plate	1	87	Flat Washer 10	2
18	Lifting Turbine	2	53	Falte Washer 5	3	88	Lock Nut M16*1.5	1
19	Lifting Turbine Shaft	1	54	Lock Washer 5	7	89	Bracket	1
20	Cap Screw M10*30	2	55	Button Head Screw M5*10	3	90	Fixed Shaft Of Motor	1
21	R-Tunnion Hanging Plate	1	56	Connecting Rod	1	91	Cotter Pin ϕ 2.5*25	2
22	Tension Pin 4*28	2	57	Locking Ring	2	92	Hex Bolt M10*25	2
23	Long Copper Sleeve	1	58	Vacuum Tube (100mm)	1	93	Motor	1
24	Set Screw M8*8	4	59	Shield Integration	1	94	Key 6*25	1
25	Hex Nut M8	4	60	Flat Washer 6	2	95	Motor Pulley	1
26	Hex Bolt M8*20	2	61	Button Head Screw M6*16	2	96	Cap Screw M8*40	4
27	C-Board Integration	1	62	Connecting Rod Screw A	2	97	Flat Washer 8	8
28	Cap Screw M6*12	6	63	Skate	1	98	Nut M8	4
29	Hex Bolt M10-45(L)	1	64	Spacer Sleeve	2	99	Pointer Integration	1
30	Brake Pin Fixing Block	1	65	Connecting Plate	1	100	Washer 5	4
31	Compression Spring	1	66	S-Copper Sleeve	1	101	Cap Screw M5*16	4
32	Brake Pin	1	67	Washer (ϕ 25* ϕ 17*2)	1	102	Angle Pointer	1
33	Connecting Rod Screw	2	68	Lock Nut M16	1	103	Flat Washer 4	1
34	Wsher 10	2	69	F-Trunnion Plate	1	104	P-Head Screw M4*8	1
35	C-Plate Follower Plate	1	70	Hex Bolt M10*40	3			

Cabinet Diagram and Part List

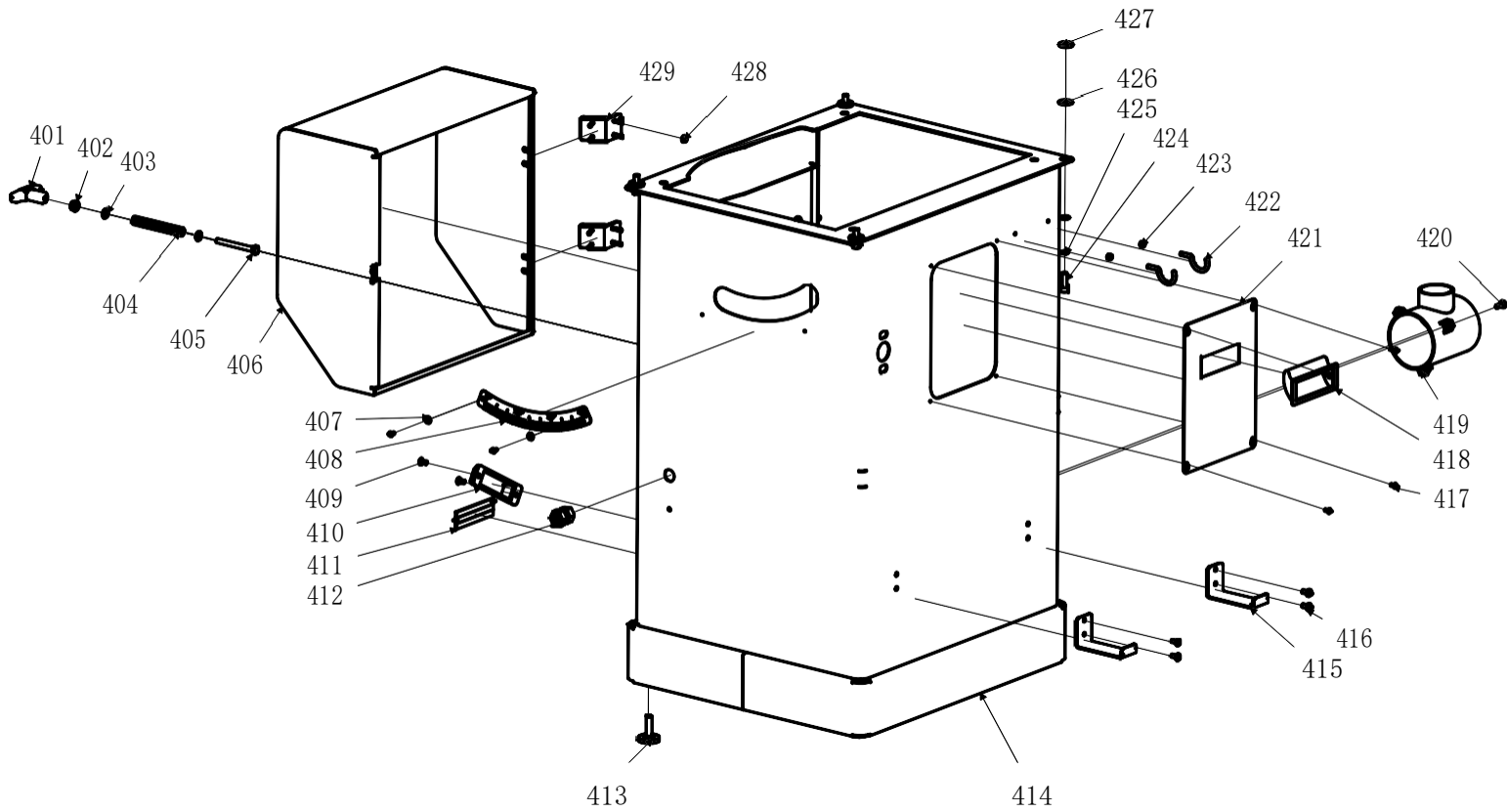

ITEM	DESCRIPTION	Q' TY	ITEM	DESCRIPTION	Q' TY
401	T-Handle	1	416	Button Head Screw M6*12	4
402	Hexagon Flange Nut M8	1	417	P-Head Screw M4*8	6
403	Washer 8	6	418	Pull Handle	1
404	Compression Spring	1	419	Dust Suction Port	1
405	Hex Bolt M8*80	1	420	Button Head Screw M6*16	3
406	Motor Guard Integration	1	421	Side Baffle Of Box	1
407	Flat Washer 4	2	422	Hook M5	2
408	Angle Scale	1	423	Nut M5	2
409	Flat Head Screw M6*12	2	424	Cap Screw M8*25	4
410	Place The Bracket	1	425	Lock Washer 8	4
411	Damping Strip	3	426	Flat Washer 8	4
412	Strain Relief	1	427	Rubber Pad	4
413	Rubber Mat M8*16	4	428	Hexagon Flange Nut M5	8
414	Sheet Metal Box	1	429	Hinge 40*40	2
415	Bracket	2			

Miter Guage With Stop Device

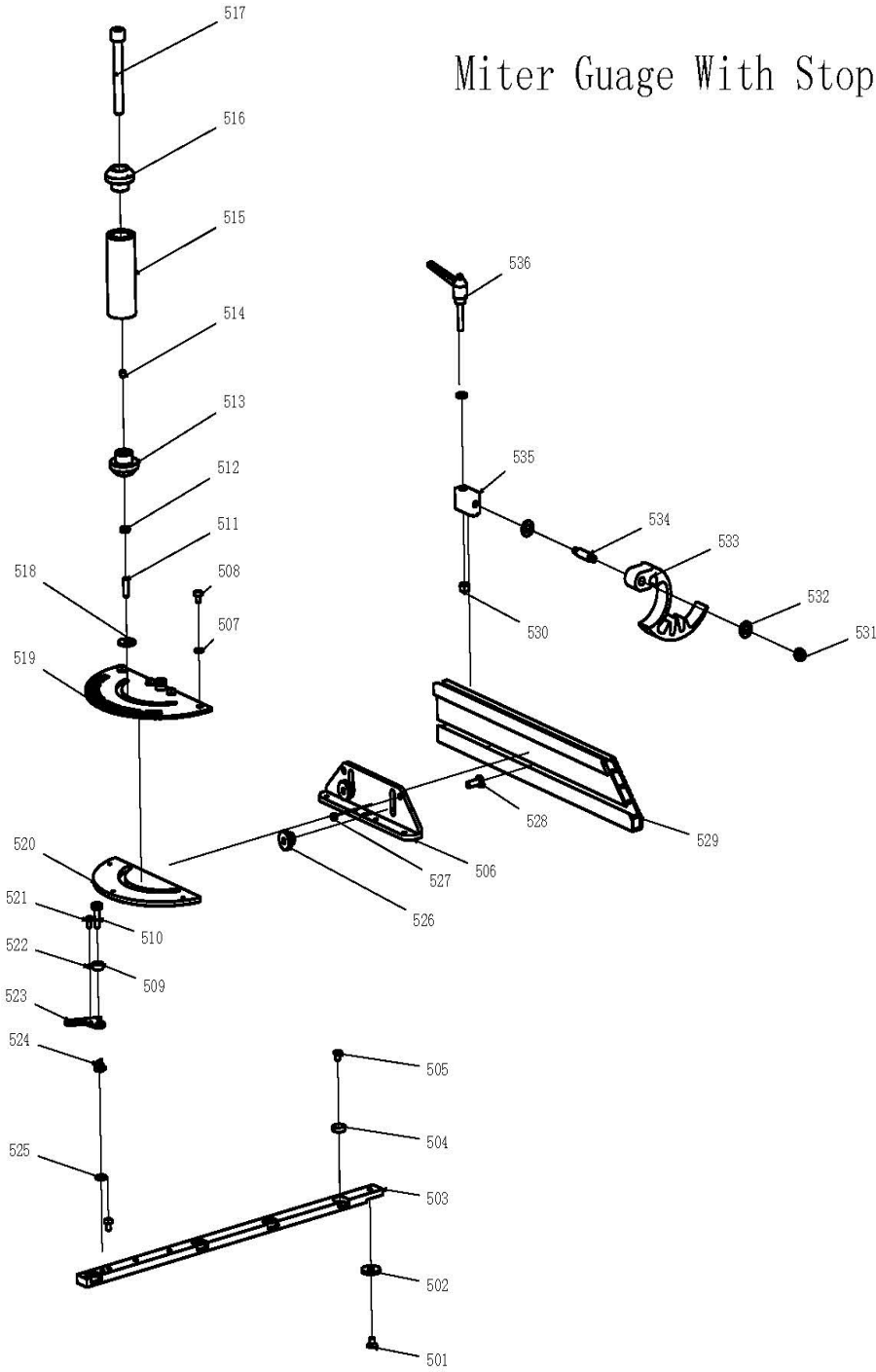

501	P-Head Screw M6-8	1
502	T-Solt Washer	1
503	Miter Bar	1
504	Washer $\phi 15-\phi 5-4$	4
505	Flat Head Screw M5*8	4
506	Locating Plate	1
507	Flat Washer $\phi 5$	4
508	Button Head Screw M5*8	5
509	Washer $\phi 6-\phi 12-5$	2
510	Plug Screw	2
511	Set Screw M6*20	1
512	Hex Nut M6	1
513	Locking Front Sleeve	1
514	Set Screw M6*6	1
515	Locking Drip	1
516	Locking Rear Sleeve	1
517	Cap Screw M10*85	1
518	Washer $\phi 6-\phi 20-1$	1
519	Angle Ruler Plate	1
520	Angle Ruler Base	1
521	Button Head Screw M4*8	1
522	Lock Washer $\phi 4$	1
523	Stop Plate	1
524	Torsion Spring	1
525	Flat Washer $\phi 6$	2
526	Combination Nut M6	2
527	Set Screw M6*6	2
528	Hex Bolt M6*16	2
529	L-Aluminum Baffle	1
530	Nut M6	1
531	Lock Nut M6	1
532	Screw $\phi 8.2-\phi 16-1.5$	2
533	Stop Plate	1
534	Fixed Shaft	1
535	Fixed Block	1
536	Locking Handle M6*30	1

High-Low Fence Diagram and Part List

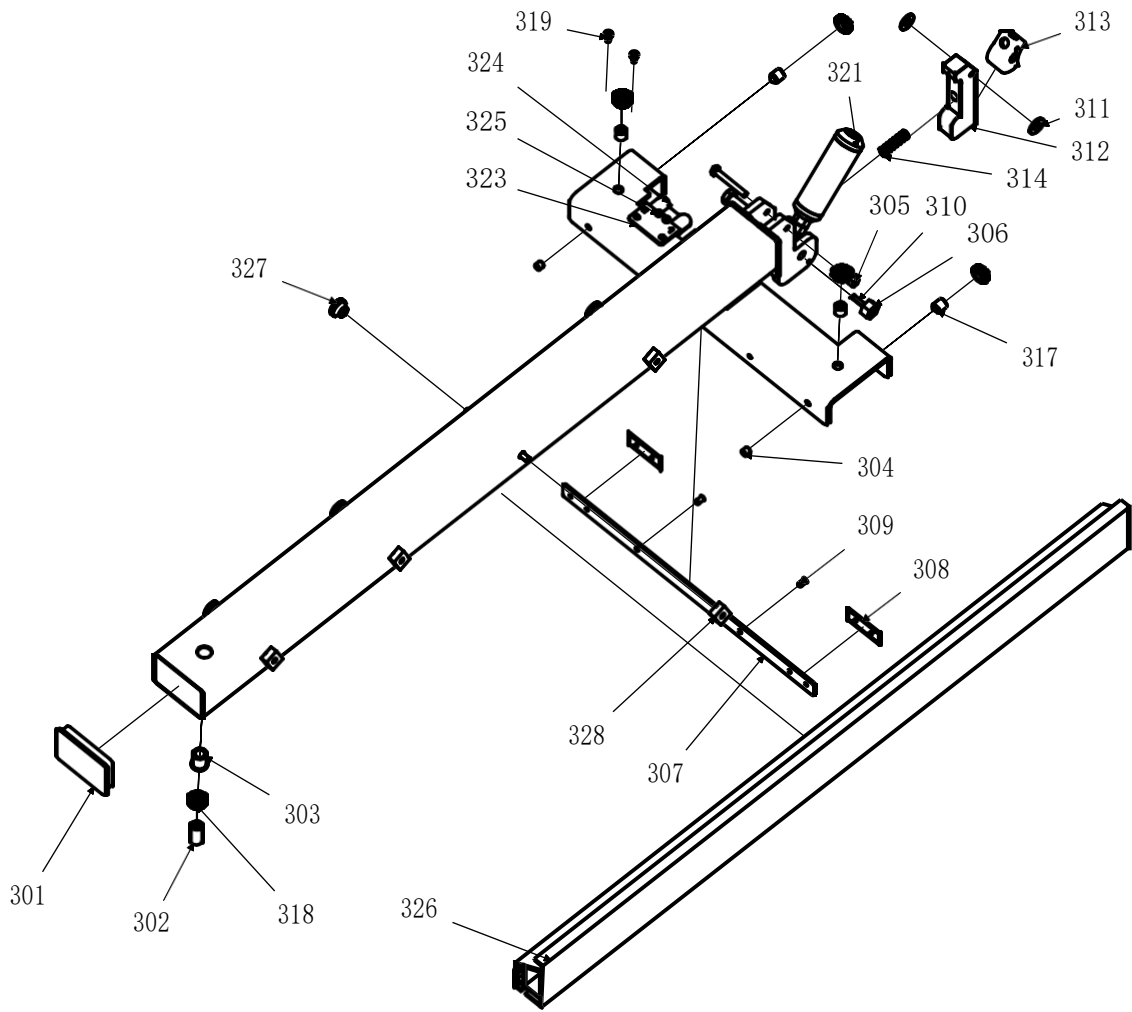

ITEM	DESCRIPTION	Q' TY	ITEM	DESCRIPTION	Q' TY
301	Square	1	315	Hex Bolt M10*50	1
302	L-Asjusting Wire	1	316	Hex Bolt M6*45	1
303	Pull Nut	1	317	S-Asjusting Wire	4
304	Set Screw M8*8	2	318	Compound Nut	5
305	Lock Nut M6	1	319	Button Head Screw M5*10	2
306	Lock Nut M10	1	320	Bracket Assembly	1
307	Transverse Plate 2	1	321	Lock Handle	1
308	Square Plug	2	322	Nut M10	2
309	Rivet	2	323	Fixed Frame	1
310	Tension Pin 4*32	1	324	Ruler	1
311	Spacer	2	325	Self Tapping Thread 3.9*10	2
312	Locking Block	1	326	Backboard	1
313	Cam Block	1	327	Combination Nut M6	4
314	Compression Spring	1	328	Locking E-Integration	4

T-Glide Fence Diagram and Part List

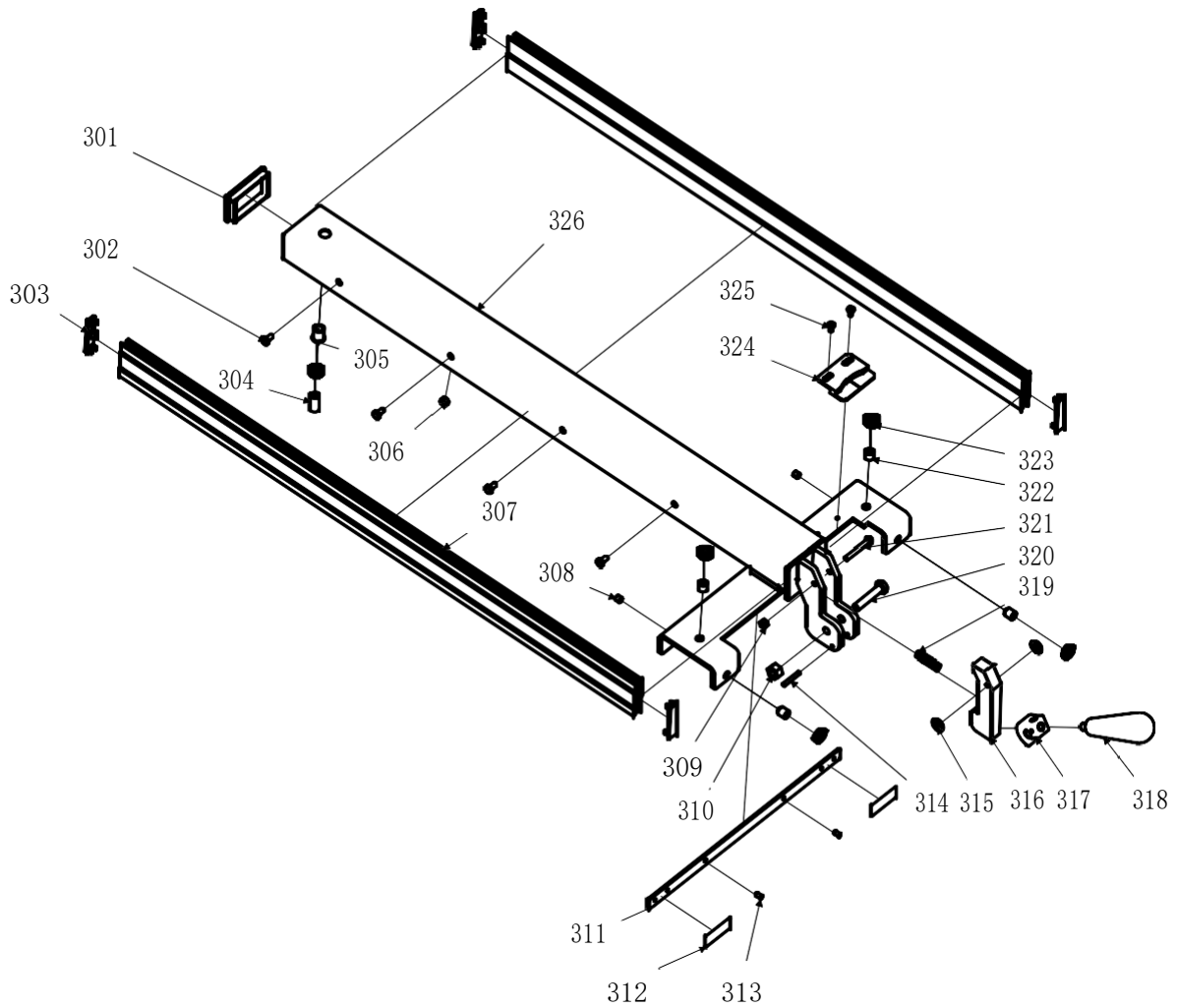

ITEM	DESCRIPTION	Q' TY	ITEM	DESCRIPTION	Q' TY
301	Square	1	314	Tension Pin 4*32	1
302	Hex Bolt M6*12	8	315	Spacer	2
303	Backing Plate Plug	4	316	Locking Block	1
304	L-Asjusting Wire	1	317	Cam Block	1
305	Pull Nut	1	318	Locking Handle M10	1
306	Nut M6	8	319	Compression Spring	1
307	Backing Board	2	320	Hex Bolt M10*50	1
308	Set Screw M8*8	2	321	Hex Bolt M6*45	1
309	Lock Nut M6	1	322	S-Asjusting Wire	4
310	Lock Nut M10	1	323	Compound Nut	5
311	Transverse Plate 2	1	324	Ruler Pointer	1
312	Square Plug	2	325	Button Head Screw M5*10	2
313	Rivet	2	326	Bracket Assembly	1