

Обозначение/ Исполнение	A	B	C	D	E	F	G	H	I	J	K	L	M	N	O	P	Q	R	S	T	V	W
32	140	47	93	28	32	15	27,5	22	17	6	M10x1,25	M6x1	9,5	13,7	G1/8"	3,5	7,5	7	45	33	12	10
40	142	49	93	32	34	15	27,5	24	17	7	M12x1,25	M6x1	9,5	13,5	G1/4"	6	8,2	9	50	37	16	14
50	150	57	93	38	42	15	27,5	32	23	8	M16x1,5	M6x1	9,5	13,5	G1/4"	8,5	8,2	9	62	47	20	17
63	153	57	96	38	42	15	27,5	32	23	8	M16x1,5	M8x1,25	9,5	13,5	G3/8"	7	8,2	8,5	75	56	20	17
80	182	75	108	47	54	21	33	40	26	10	M20x1,5	M10x1,5	11,5	16,5	G3/8"	10	8,2	14	94	70	25	22
100	189	75	114	47	54	21	33	40	26	10	M20x1,5	M10x1,5	11,5	16,5	G1/2"	11	9,5	14	112	84	25	22
125	246	101	145	57	69	32	40	54	39	11	M27x2	M12x1,75	15	20	G1/2"	-	9,5	-	140	110	32	29
160	315	135	180	65	80	36	50	60	52	14	M36x2	M16x2	15	25	G3/4"	-	-	-	180	140	40	36
200	334	149	185	80	80	48	50	60	52	14	M36x2	M16x2	30	25	G3/4"	-	-	-	220	175	50	46
250	384	189	195	90	119	70	50	84	65	21	M42x2	M20x2,5	30	25	G3/4"	-	-	-	280	220	50	46
320	440	206	234	110	126	80	55	96	75	24	M48x2	M24x3	40	27,5	G1"	-	-	-	350	280	70	65
400	440	190	250	128	110	80	60	70	85	28	M56x2	M30x3,5	40	30	G1"	-	-	-	430	350	80	76

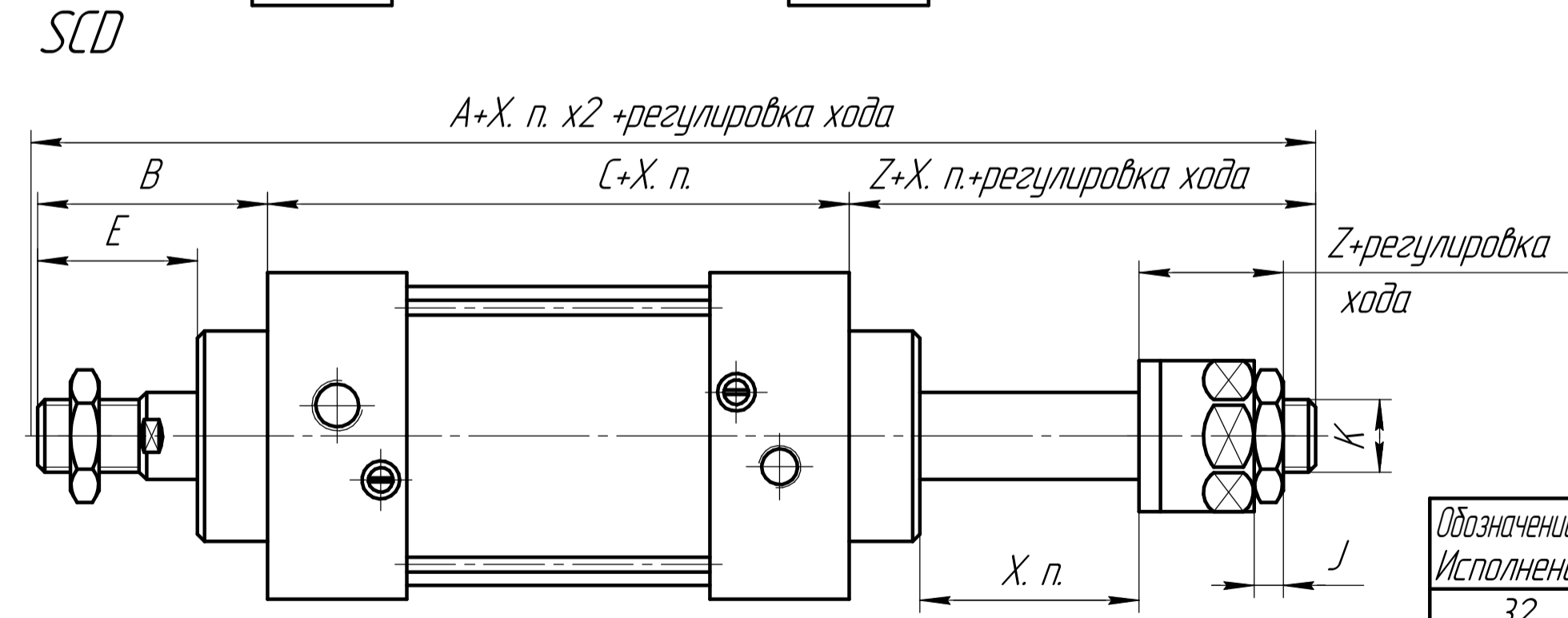
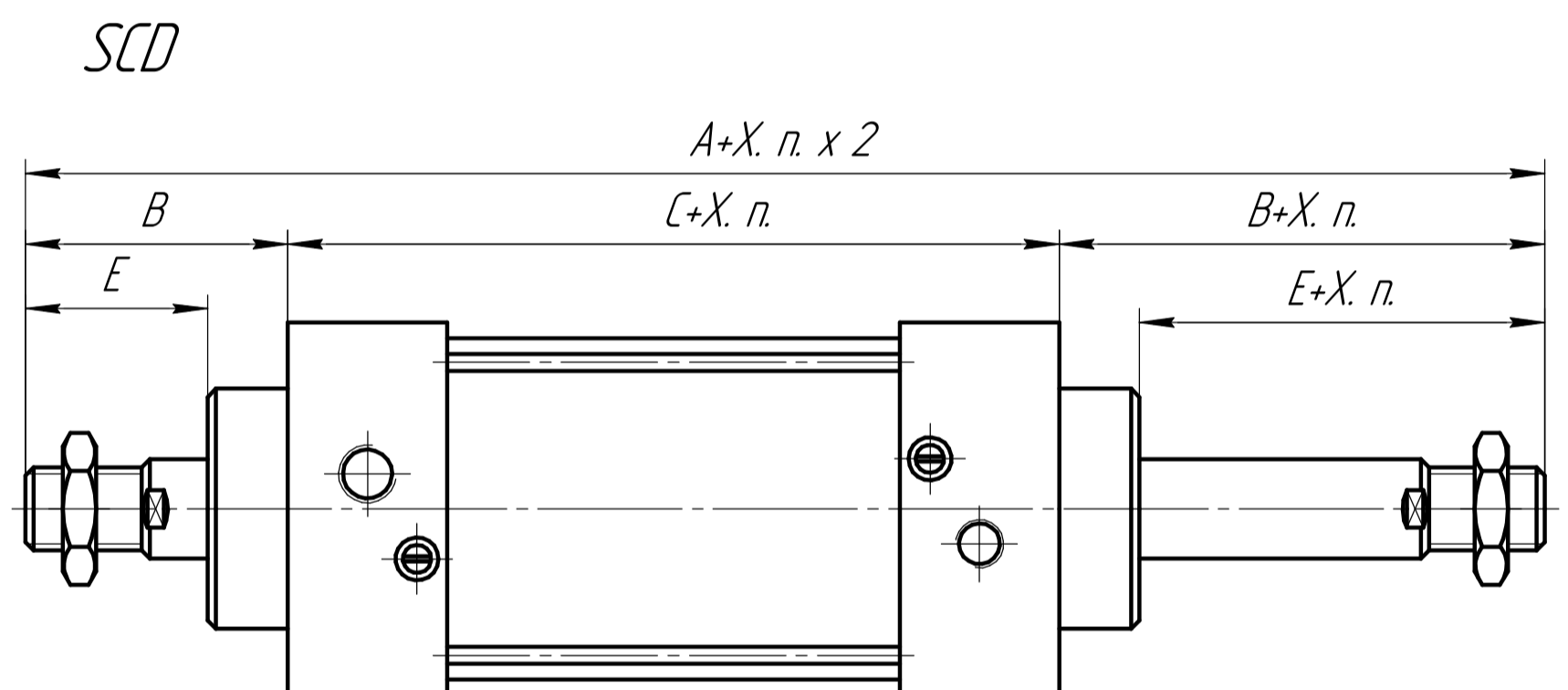

Обозначение/ Исполнение	A1	A2	B	C	E	Z	J	K
32	187	182	47	93	32	27	6	M10x1,25
40	191	185	49	93	34	28	7	M12x1,25
50	207	194	57	93	42	29	8	M16x1,5
63	210	197	57	96	42	29	8	M16x1,5
80	257	238,5	75	107	54	35,5	10	M20x1,5
100	263	244,5	75	113	54	35,5	10	M20x1,5

1 Размеры для справок.
2 Производитель оставляет за собой право изменять размеры и габариты моделей без уведомления.

Изм./Лист	№ докум.	Подп.	Дата	Пневмоцилиндр серии SC	Лит.	Масса	Масштаб
Разраб.							
Пров.					Лист	Листов	1
Т.контр.							
Н.контр.							
Утв.							