

REV.	DESCRIPTION	DRAWN	CHECKED	APPROVED

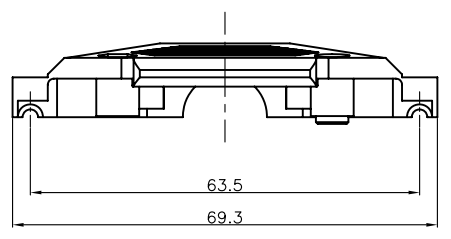

BOM LIST			
ITEM	PART NAME	Q'ty	NOTES
1	PLASTIC HOOD	2	ABS
2	BOLT	2	#4-40
3	NUT	2	M3
4	LONG SCREW	2	M3
5	SMALL WASHER	2	
6	SHORT SCREW	2	M3
7	BIG WASHER	2	M3

NOTES:  
 1. Hardwares are all Nickel plated.  
 2. PART NUMBER CODE:

DS1045 - 37 X X X X X  
 Bolt type  
 L: Long  
 S: Short  
 Packing type  
 1: Mix packing  
 2: Separation packing  
 Cover Color  
 A: Gray  
 B: Black  
 Cover Material  
 P: Plastic(ABS)  
 Position  
 37: 37pin

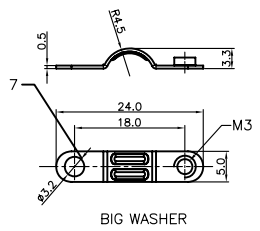
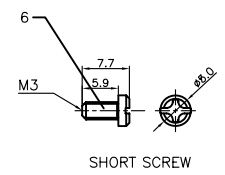
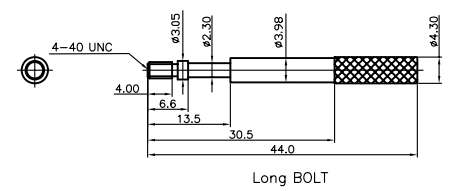
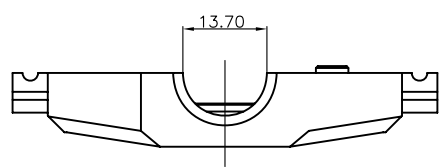
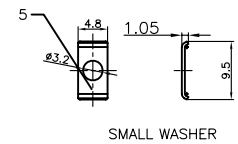
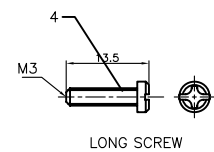
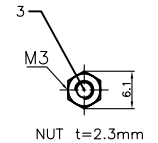
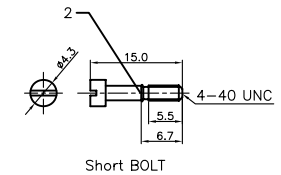
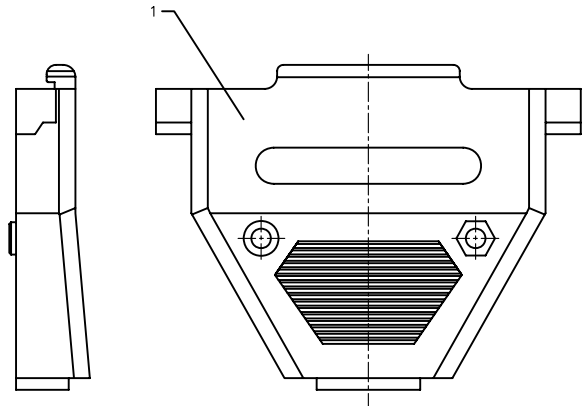
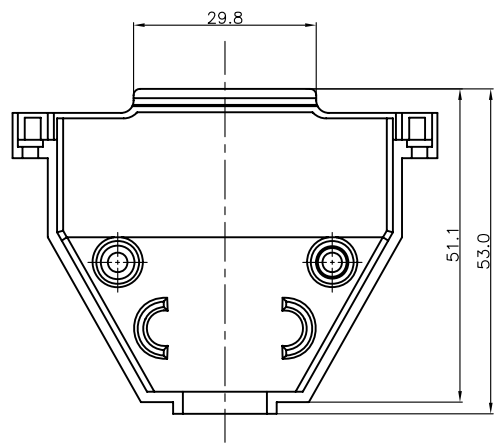
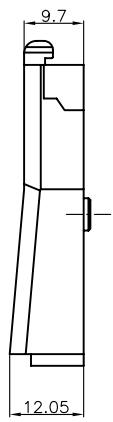
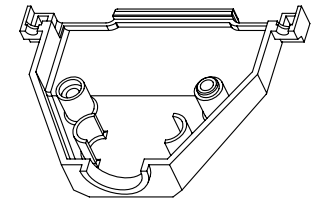

GENERAL TOLERANCE		ANGLE TOLERANCE		PROJECTION	TITLE
X.	±0.60	X.	±5°		D-SUB 37pin Cover
.X	±0.38	.X	±3°	mm	
.XX	±0.25	.XX	±2°		SHEET SIZE A4
DRAWING TYPE				SERIES DS1045 SERIES	
SCALE				DP-37C	
DRAWING NO.				C-DS1045-37XXXX	
DRAWING TYPE		COSTOMER			
SCALE		1:1		SHEET 1 OF 1	
DRAWING NO.		C-DS1045-37XXXX			