

Capacitor-Coupled, Switched Shunt, (CCSS) Regulator

Features

- ▶ Efficiencies up to 75% at 20mA
- ▶ Less than 20mW standby power
- ▶ Optional 6.0V, 12V or 24V fixed output voltage, or adjustable from 6.0V to 28V
- ▶ Output current scalable up to 50mA
- ▶ 120VAC to 240VAC input
- ▶ No magnetics
- ▶ Inherent short circuit protection

Applications

- ▶ Household appliances
- ▶ White goods
- ▶ Lighting controls
- ▶ Utility meters

General Description

The Supertex SR10 is a non-isolated, capacitor-coupled, switched shunt regulator designed to operate directly from the AC line. Output voltage can be either fixed at 6.0V, 12V, or 24V using an internal feedback divider or be adjusted over a 6.0V to 28V range using an external feedback divider. Output current capability is scalable to 50mA, by selection of the series coupling capacitor (C_s) on the AC line. Standby power can be under 20mW, and efficiencies of 75% are possible depending upon configuration and degree of transient protection.

All components except for C_s are low voltage, easing PCB layout and alleviating high voltage creepage concerns.

Inherent short circuit protection is afforded by the reactance of the C_s series capacitor, which limits current even with a dead short on the output. Overcurrent protection (OCP) shuts off the shunt during a line transient.

Refer to application note AN-H65 for further information.

Typical Application Circuits

Full-wave Rectification

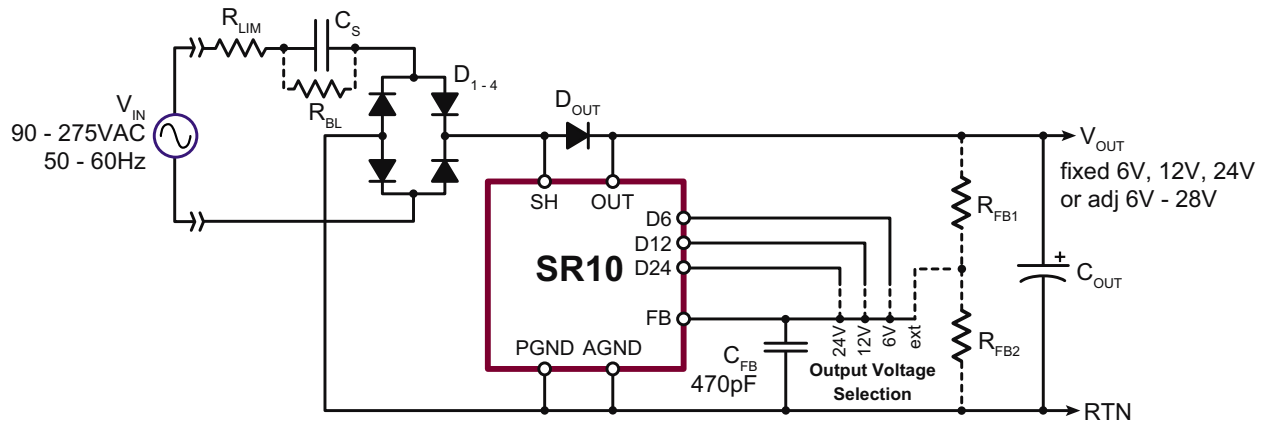

Half-wave Rectification

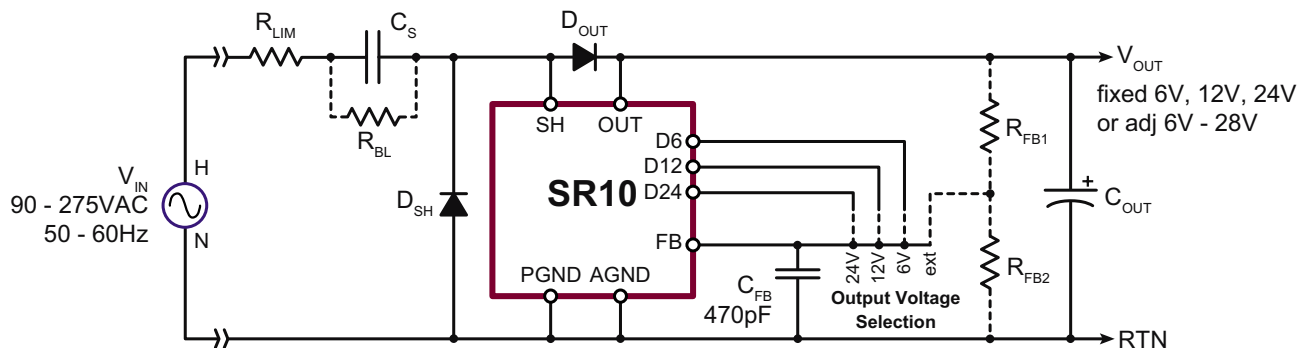

Ordering Information

Device	8-Lead SOIC 4.90x3.90mm body 1.75mm height (max) 1.27mm pitch
SR10	SR10LG-G

-G indicates package is RoHS compliant ('Green')



Absolute Maximum Ratings

Parameter	Value
V_{OUT}, V_{SH}	40V
V_{FB}	5.0V
PGND – AGND	±300mV
$I_{IN(RMS)}$ (SH to PGND)	300mARMS
I_{DSH} (PGND to SH)	300mA
Operating junction temperature	-40°C to +125°C

Absolute Maximum Ratings are those values beyond which damage to the device may occur. Functional operation under these conditions is not implied. Continuous operation of the device at the absolute rating level may affect device reliability. All voltages are referenced to device ground.

Pin Configuration

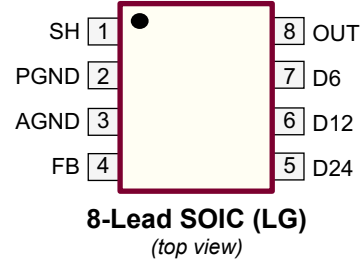

Product Marking



YY = Year Sealed
WW = Week Sealed
L = Lot Number
_____ = "Green" Packaging

Package may or may not include the following marks: Si or

8-Lead SOIC (LG)

Recommended Operating Conditions

Sym	Parameter	Min	Typ	Max	Units	Conditions
I_{SH}	Peak shunt current	See Maximum Shunt Current Graph			---	---
V_{OUT}	Output voltage	6.0	-	28	V	---

Electrical Characteristics (Unless otherwise noted, $T_A = 25^\circ\text{C}$, Voltages referenced to PGND/AGND pin)

Sym	Parameter	Min	Typ	Max	Unit	Conditions
V_{FB}	Feedback threshold (shunt turn-off)	1.02	1.20	1.38	V	$T_A = 25^\circ\text{C}$ $T_A = -40^\circ\text{C}$ to $+85^\circ\text{C}^1$
I_{FB}	FB input bias current	-	-	±1.0	µA	---
A_{DIV}	Internal feedback divider ratio:	D6: 4.85 D12: 9.70 D24: 19.40	5.00 10.00 20.00	5.15 10.30 20.60	V/V	$V_{OUT} = 6.0\text{V}$ $V_{OUT} = 12\text{V}$ $V_{OUT} = 24\text{V}$
R_{DIV}	Internal divider resistance ¹	-	500	-	kΩ	OUT to AGND
R_{SH}	Shunt on resistance	-	3.0	7.0	Ω	100mA SH to PGND 100mA PGND to SH
I_{SH}	Max shunt current	220	-	-	mA	$V_{SH} < 1.2\text{V}$, 25°C
		180	-	-		85°C^1
V_D	Shunt diode voltage drop	-	880	-	mV	$I_D = 220\text{mA}$

Note:
1. Guaranteed by design.

Electrical Characteristics (Unless otherwise noted, $T_A = 25^\circ\text{C}$, Voltages referenced to PGND/AGND pin)

Sym	Parameter	Min	Typ	Max	Unit	Conditions
I_{BIAS}	Bias current into OUT pin	-	220	400	μA	28V applied to the OUT pin
R_{PD}	Pull-down resistance on SH	40	50	60	$\text{k}\Omega$	$V_{SH} = 1.5\text{V}$
V_{SYNC}	Voltage at SH to turn the shunt on (SYNC)	2.0	2.3	2.5	V	---
V_{OCP}	Voltage at SH to turn the shunt off when on (OCP)	2.0	2.3	2.5	V	Shunt on
t_{FALL}	Shunt current fall time	-	15	-	μs	90 - 10%, $I_{SH} = 100\text{mA}$
t_{OCP}	OCP response time	-	15	-	μs	Shunt on, $I_{SHUNT} < 10\text{mA}$, See Figure 3

Maximum Shunt Current

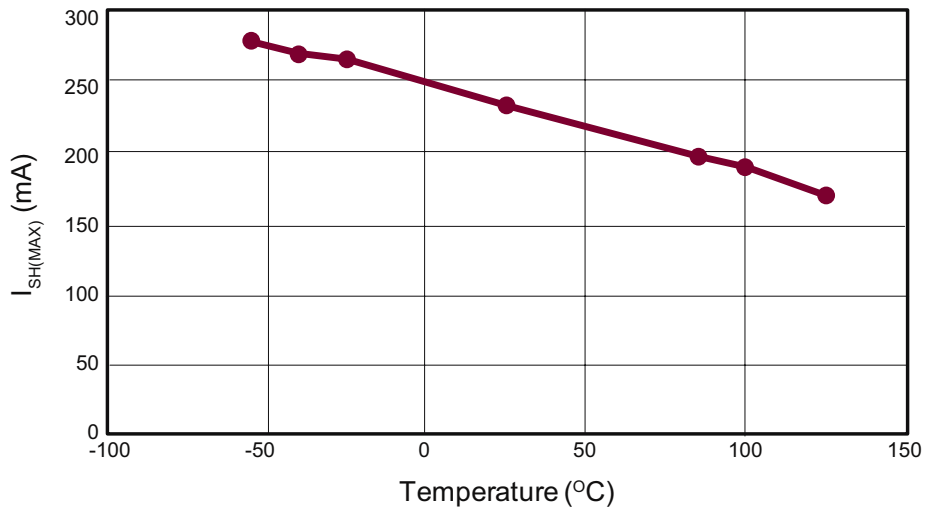

Internal Block Diagram

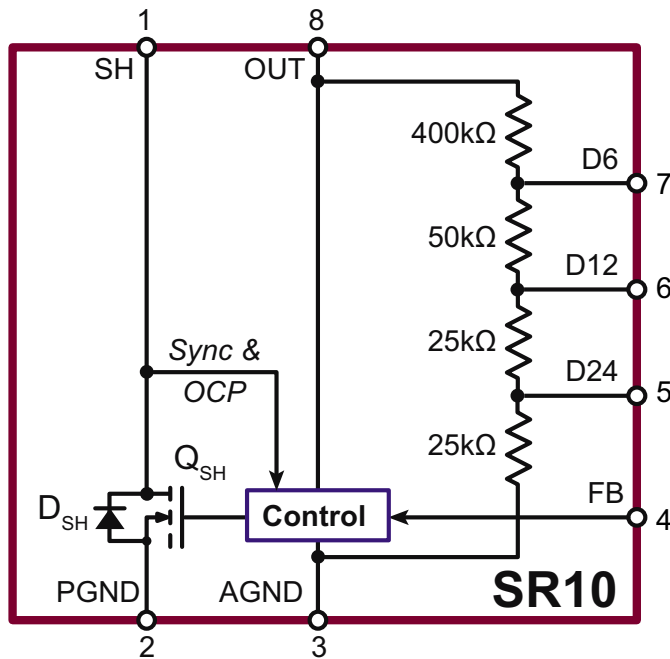

Figure 1: OCP Timing

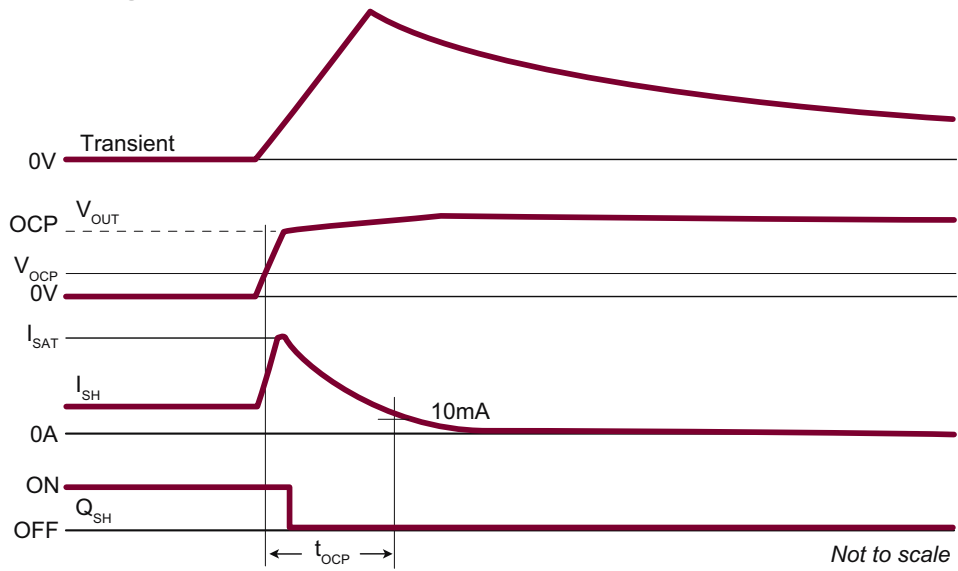

Figure 2: Shunt Diode Characteristics

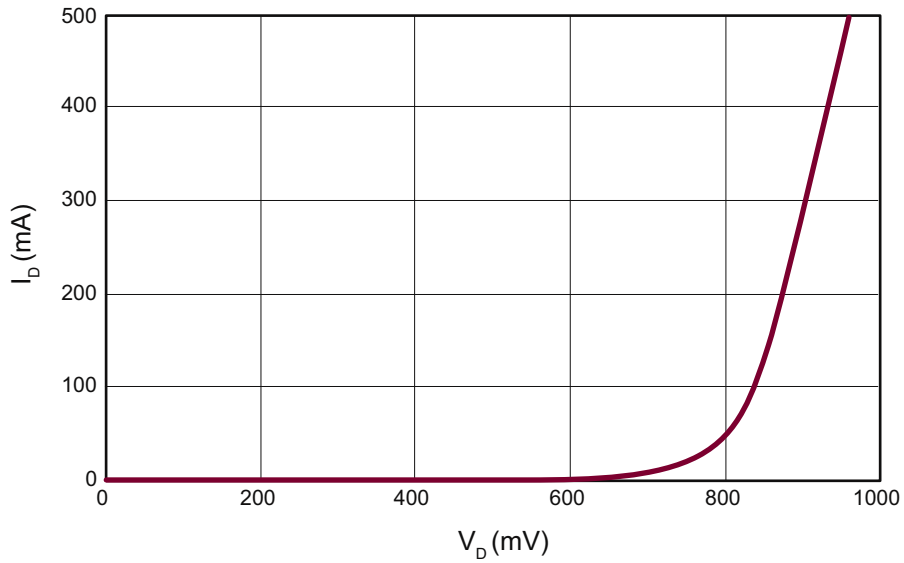
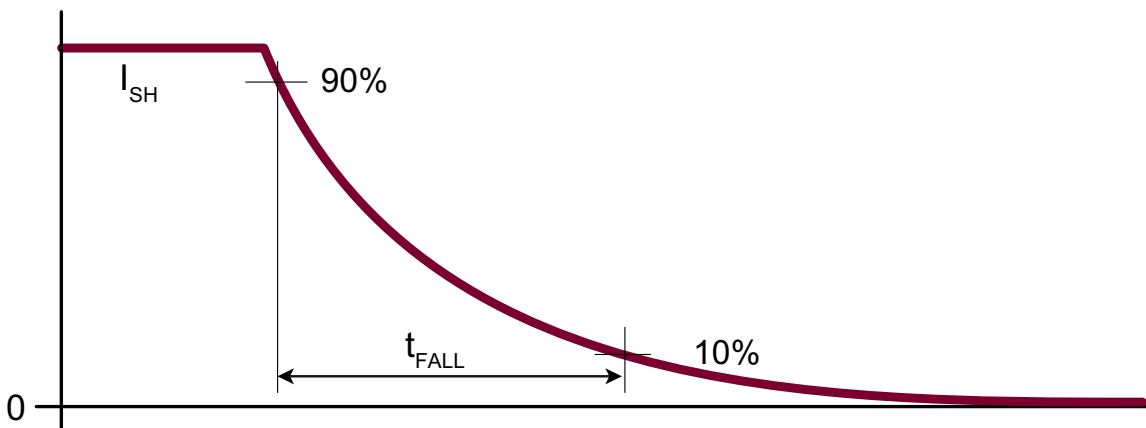

Figure 3: Shunt Turn-off Fall Time



Application Information

The SR10 is a capacitor-coupled, switched shunt regulator. Capacitor-coupling to the AC line limits input current due to the finite charge per cycle that can be transferred. Contrast-

ing with a traditional Zener shunt, the switched shunt operates either fully on or fully off, resulting in low standby power consumption.

Simplified Schematic

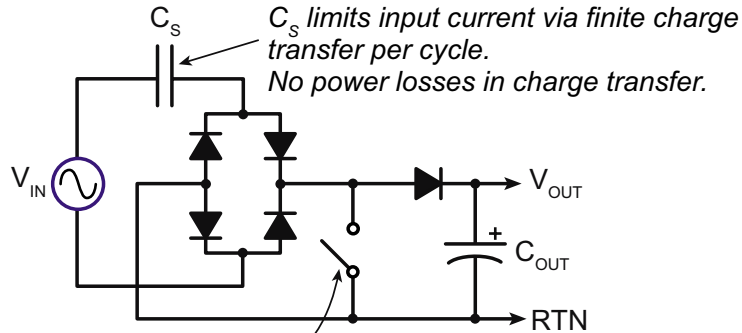

Shunt operates either fully on or fully off.
No power-wasting linear operation.

Timing

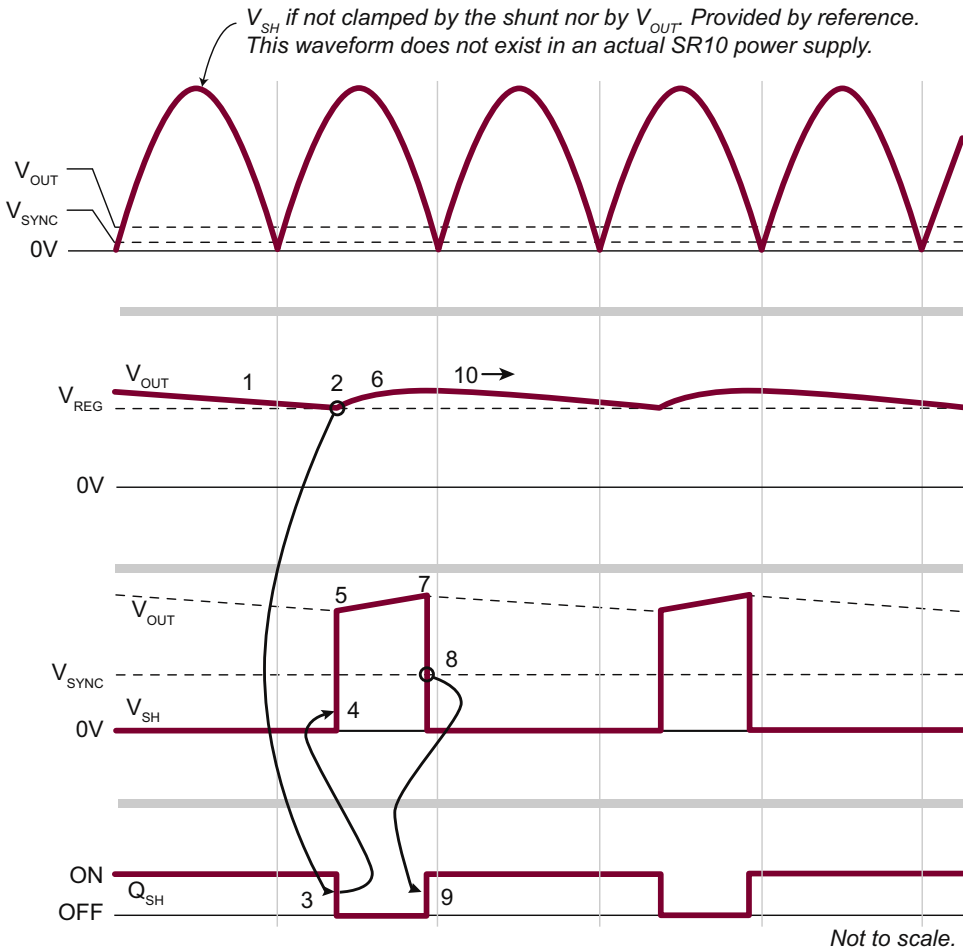

1. Output voltage decays under load until ...
2. it hits the regulation point which...
3. turns off the shunt...
4. freeing V_{SH} to rise...
5. until it is clamped by V_{OUT} where...
6. Input current flows to the output, causing V_{OUT} to rise...
7. until V_{SH} falls below V_{OUT}
8. When it reaches V_{SYNC} ...
9. the shunt is turned on and current no longer flows to the output.
10. The cycle repeats.

Output Current Capability

Output current capability is largely a function of capacitor C_s and the input voltage. The following table provides approximate current capability for various C_s values and line voltages. Actual current will be less due to losses. Higher output voltages slightly reduce output current capability.

C_s Table

The following table is based on the previously provided equations for C_s . Actual output current may be less due to losses (~5% less). AC line voltage is assumed to be 90 - 135VRMS @ 60Hz or 190 - 275VRMS @ 50Hz. Slashed cells exceed recommended operating conditions for peak shunt current at 85°C.

For universal 120V and 240V operation choose C_s based on 120VAC and make sure that operation at 240VAC does not fall in a slashed cell. The relevant cells are adjacent to each other. For example, if 50mA at 12V is needed and full rectification used, a C_s capacitor of $2.2\mu F \pm 10\%$ provides 53.8mA at 120VAC (90VAC low line). But at 240VAC, the cell to the right (240VAC column) is slashed, and universal operation is not possible. This assumes 120VAC low line is 90VAC and 240VAC high line is 275VAC. For other high/low voltages use the equations.

Output current capability (mA)

C_s	C_s Tol	6V Output				12V Output				24V Output			
		Half		Full		Half		Full		Half		Full	
		120V 60Hz	240V 50Hz	120V 60Hz	240V 50Hz	120V 60Hz	240V 50Hz	120V 60Hz	240V 50Hz	120V 60Hz	240V 50Hz	120V 60Hz	240V 50Hz
220nF	10%	2.9	5.2	5.7	10.3	2.9	5.2	5.4	10.1	2.7	5.1	4.8	9.6
	20%	2.6	4.7	5.0	9.2	2.5	4.6	4.8	9.0	2.4	4.5	4.3	8.5
330nF	10%	4.4	7.9	8.5	15.5	4.3	7.8	8.1	15.1	4.1	7.6	7.2	14.4
	20%	3.9	7.0	7.6	13.8	3.8	6.9	7.2	13.4	3.6	6.8	6.4	12.8
470nF	10%	6.3	11.2	12.1	22.0	6.1	11.1	11.5	21.5	5.8	10.8	10.3	20.5
	20%	5.6	10.0	10.8	19.6	5.4	9.9	10.2	19.1	5.2	9.6	9.1	18.2
680nF	10%	9.1	16.2	17.5	31.9	8.9	16.0	16.6	31.2	8.4	15.7	14.9	29.7
	20%	8.1	14.4	15.6	28.4	7.9	14.3	14.8	27.7	7.5	13.9	13.2	26.4
1.0μF	10%	13.3	23.9	25.7	46.9	13.0	23.6	24.4	45.8	12.4	23.0	21.9	43.7
	20%	11.9	21.2	22.9	41.7	11.6	21.0	21.7	40.7	11.0	20.5	19.4	38.8
1.5μF	10%	20.0	35.8	38.6	70.4	19.5	35.4	36.7	68.7	18.6	34.6	32.8	65.5
	20%	17.8	31.8	34.3	62.5	17.4	31.4	32.6	61.1	16.5	30.7	29.1	58.2
2.2μF	10%	29.4	52.5	56.6	103.2	28.6	51.9	53.8	100.8	27.2	50.7	48.1	96.1
	20%	26.1	46.6	50.3	91.7	25.5	46.1	47.8	89.6	24.2	45.1	42.7	85.4

 = Exceeds Recommended Operating Limits

Output Voltage

The output voltage may be adjusted over the range of 6V to 28V using either the SR10's internal feedback divider or by using an external divider. The internal divider has taps for 6V, 12V, and 24V which are brought out to pins D6, D12, and D24 respectively. Connecting the appropriate tap to the

feedback pin (FB) provides the chosen output voltage. If an output voltage other than that provided by the internal divider is required, an external feedback divider from V_{OUT} to the FB pin may be used. The range is from 6V to 28V.

FB pin connected to...	Output Voltage
D6	6V
D12	12V
D24	24V
External divider	$V_{OUT} = 1.2V \left(1 + \frac{R_{FB1}}{R_{FB2}} \right)$

Note:

A 470pF capacitor from FB pin to AGND pin minimizes the effects of a noisy AC line.

Pin Description

Name	Pin	Description
SH	1	Shunt
PGND	2	Power ground for the shunt
AGND	3	Analog ground for the controller
FB	4	Feedback input
D24	5	Internal feedback divider 24V tap
D12	6	Internal feedback divider 12V tap
D6	7	Internal feedback divider 6.0V tap
OUT	8	Connect to regulator output

Note:

All pins are low voltage.

Additional Information

For a more detailed description or for sample circuits, an application note and a demo board are available.

AH-H65

CCSS Application Note

- Explains the operating principle of the capacitor-coupled, switched shunt regulator
- Provides design equations and guidelines
- Specifies special testing considerations

SR10DB1

SR10 Demo Board

- Jumper-selectable half-wave or full-wave recitfication
- Jumper-selectable output voltage
- Socketed components allow easy optimization

8-Lead SOIC (Narrow Body) Package Outline (LG)

4.90x3.90mm body, 1.75mm height (max), 1.27mm pitch

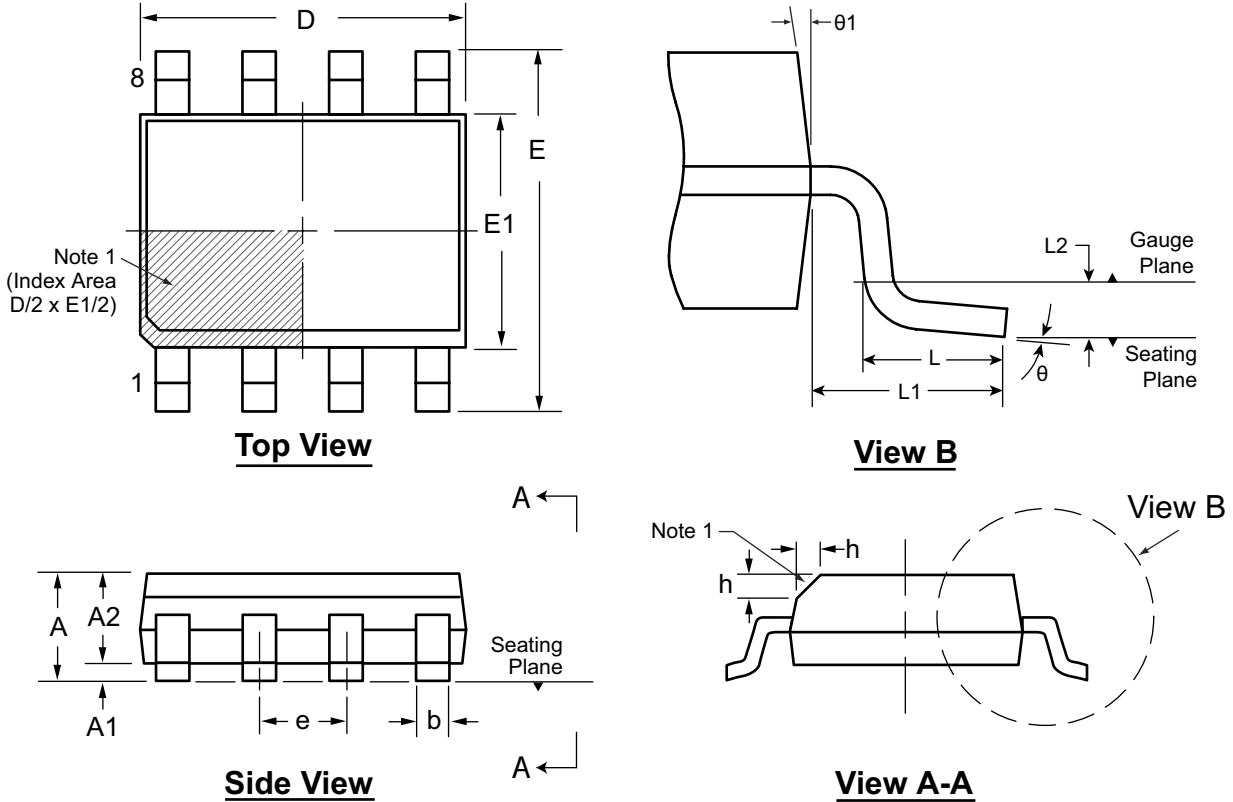

Note:
 1. This chamfer feature is optional. A Pin 1 identifier must be located in the index area indicated. The Pin 1 identifier can be: a molded mark/identifier; an embedded metal marker; or a printed indicator.

Symbol	A	A1	A2	b	D	E	E1	e	h	L	L1	L2	θ	θ1	
Dimension (mm)	MIN	1.35*	0.10	1.25	0.31	4.80*	5.80*	3.80*	1.27 BSC	0.25	0.40	1.04 REF	0.25 BSC	0°	5°
	NOM	-	-	-	-	4.90	6.00	3.90		-	-			-	-
	MAX	1.75	0.25	1.65*	0.51	5.00*	6.20*	4.00*		0.50	1.27			8°	15°

JEDEC Registration MS-012, Variation AA, Issue E, Sept. 2005.

* This dimension is not specified in the JEDEC drawing.

Drawings are not to scale.

Supertex Doc. #: DSPD-8SOLGTG, Version I041309.

(The package drawing(s) in this data sheet may not reflect the most current specifications. For the latest package outline information go to <http://www.supertex.com/packaging.html>.)

Supertex inc. does not recommend the use of its products in life support applications, and will not knowingly sell them for use in such applications unless it receives an adequate "product liability indemnification insurance agreement." **Supertex inc.** does not assume responsibility for use of devices described, and limits its liability to the replacement of the devices determined defective due to workmanship. No responsibility is assumed for possible omissions and inaccuracies. Circuitry and specifications are subject to change without notice. For the latest product specifications refer to the **Supertex inc.** (website: <http://www.supertex.com>)